

Instruction Manual

TAPIR
Helium Leak Detector
HL 2216 A



Ateliers Busch S.A.
Zone industrielle,
2906 Chevenez
Switzerland

Table of contents

1	About this manual	5
1.1	Validity	5
1.1.1	Applicable documents	5
1.2	Conventions	6
1.2.1	Safety instructions	6
1.2.2	Pictographs	7
1.2.3	Instructions/Abbreviations used	7
1.2.4	Labels	7
2	Safety	9
2.1	Safety precautions	9
2.2	Protective equipment	10
2.3	Proper use	11
2.4	Improper use	11
3	Transport and storage	12
3.1	Transport	12
3.2	Storage	12
4	Product description	14
4.1	Product identification	14
4.1.1	Scope of delivery	14
4.2	Interface connection	15
4.3	Test methods	15
4.3.1	Hard vacuum test	15
4.3.2	Sniffing test mode	16
5	Installation	17
5.1	Prerequisites for optimising measurement	17
5.2	Operating conditions	17
5.3	Set-up	17
5.3.1	Storing the lifting handles	17
5.3.2	Control panel equipment	18
5.4	Filling with oil	18
5.5	Connection to the mains power supply	19
5.6	Operating for the first time	19
5.6.1	Familiarise yourself with the control panel	20
5.6.2	Become familiar with the detector	20
5.7	Connecting the part/installation to be tested	20
5.8	Connecting the exhaust	20
6	Operation	22
6.1	Control panel	22
6.1.1	Description	22
6.1.2	Contrast - Brightness - Screen Saver	23
6.1.3	Application screens	24
6.1.4	"Standard" screen	25
6.1.5	"Settings" screen	25
6.1.6	"Graph" screen	26
6.1.7	"Vacuum circuit" screen	26
6.1.8	"Measurement" window	26
6.1.9	Function keys	26
6.2	Prerequisites to use	27
6.3	Switching the detector on	27
6.3.1	Switch on	27
6.3.2	Starting a test	27

6.4	Monitoring operation	28
6.5	Shutdown the detector	28
6.6	Saving and downloading the product's configuration	28
6.6.1	Saving the configuration	28
6.6.2	Downloading the configuration	29
7	Advanced settings	30
7.1	"Graph" screen	30
7.1.1	Description	30
7.1.2	Settings	30
7.1.3	Recording	31
7.1.4	Graph clearing	31
7.1.5	Viewing a recording	32
7.1.6	Saving a recording	34
7.2	Settings	34
7.2.1	Tree diagram of the "Settings" menus	34
7.3	Set points Menu	41
7.3.1	Audio alarm and digital voice	42
7.3.2	Pollution function	42
7.3.3	Hard Vacuum reject point	42
7.3.4	Sniffing reject set point	43
7.3.5	Probe clogged set point	43
7.4	"Test" Menu	44
7.4.1	Test methods	44
7.4.2	Correction factor	45
7.4.3	Test mode	45
7.4.4	Automatic Cycle End	45
7.4.5	Inlet vent	46
7.4.6	Memo function	47
7.4.7	Zero activation	47
7.4.8	Regeneration	48
7.4.9	Massive mode	48
7.5	Spectro Menu	48
7.5.1	Tracer gas	50
7.5.2	Filament parameters	50
7.5.3	Calibrated leak	50
7.6	Maintenance Menu	51
7.6.1	Detector	51
7.6.2	Timers	51
7.6.3	Detector Information	52
7.6.4	Pump Information	52
7.6.5	Event history	52
7.6.6	Calibration history	53
7.6.7	Burn-in	53
7.6.8	Maintenance for the analyzer cell and the secondary pump	54
7.7	Configuration Menu	54
7.7.1	Time - Date - Unit - Language	54
7.7.2	Function keys	55
7.7.3	Application screens	56
7.7.4	Screen Settings	57
7.7.5	Access - Password	57
7.8	Advanced Menu	60
7.8.1	Leak Detection Menu	60
7.8.2	Leak Detection: Start-up timer	61
7.8.3	Leak detection: Background suppression	61
7.8.4	Leak Detection: Crossover Pressures	61
7.8.5	Leak Detection: Calibration	61
7.8.6	Leak detection: Analyzer cell	62

7.8.7	Leak Detection: Internal Pirani gauge calibration	63
7.8.8	Leak Detection: External gauge	63
7.8.9	Input/Output menu	64
7.8.10	Input/Output: Serial Link 1 and Serial Link 2	64
7.8.11	Input/Output: I/O connector	65
7.8.12	SD Card menu	65
7.8.13	Service	65
8	Maintenance / replacement	66
8.1	Maintenance intervals and responsibilities	66
9	Service	67
10	Accessories	68
11	Technical data and dimensions	69
11.1	General	69
11.2	Technical data	69
11.3	Units of measurement	69
11.4	Dimensions	70
	EU-Declaration of conformity	71

1 About this manual

1.1 Validity

This instruction manual is for customers of Busch. It describes the functioning of the designated product and provides the most important information for safe use of the unit. The description follows applicable EU guidelines. All information provided in this operating manual refers to the current state of the product's development. The documentation remains valid as long as the customer does not make any changes to the product. Up-to-date operating instructions can also be downloaded from www.buschvacuum.com.

This manual covers products with the following part numbers:

Part number	Description
0659230708	TAPIR HL 2216 A (90-130 V, 50/60 Hz)
0659230711	TAPIR HL 2216 A (100-130 V, 50/60 Hz)
0659230714	TAPIR HL 2216 A (200-240 V, 50/60 Hz)

1.1.1 Applicable documents

Documents relevant for the use of options and/or accessories, and for product maintenance are the following:

	Part number
Operating instructions - RS-232	P/n 0870223337*
Operating instructions - 37 pin I/O board (USB)	P/n 0870232554*
Operating instructions - Sniffer Probe	P/n 0870230738*
Operating instructions - Spray Gun	P/n 0870230736*
Maintenance instructions - TAPIR HL 2216 A	P/n 0870232552*
Declaration of conformity	Included with this manual
*also available at www.buschvacuum.com	

1.2 Conventions

1.2.1 Safety instructions

Operating manual safety instructions are based on the UL, CSA, ANSI Z-535, SEMI S2, ISO 3864 and DIN 4844 certification standards. This document describes the following information and danger levels:

DANGER
Imminent danger Indicates an imminent hazardous situation that will result in death or serious injury.
WARNING
Possibly imminent danger Indicates an imminent hazardous situation that can result in death or serious injury.
CAUTION
Possibly imminent danger Indicates an imminent hazardous situation that can result in minor or moderate injury.
NOTICE
Command or note Command to perform an action or information about properties, the disregarding of which may result in damage to the product.

1.2.2 Pictographs



Prohibition of an action to avoid any risk of accidents, the disregarding of which may result in serious accidents



Warning of a displayed source of danger in connection with operation of the unit or equipment



Command to perform an action or task associated with a source of danger, the disregarding of which may result in serious accidents

1.2.3 Instructions/Abbreviations used

⇒ or →

Work instruction: you must perform an operation here.

[XXXX]

You must press the **XXXX** key on the control panel.

I/O

Inputs/Outputs



Example: press the "Home" key on the control panel to return to the «Standard» screen.

⁴He

Helium 4

³He

Helium 3

H₂

Hydrogen

1.2.4 Labels

This chapter lists all the labels that could appear on the product as well as their meaning.

FR AEOF 00165062 - assurance qualité / quality control

Safety label: guarantee that the packing has not been opened since leaving the factory.



Indicates that the operator must:

- ⇒ handle the product using the devices shown on this label,
- ⇒ comply with the rules for moving the equipment, taking weight and dimensions into account.



Indicates an electric shock hazard in case of contact:

- ⇒ do not use the product if the power cable is not earthed,
- ⇒ disconnect the electrical power supply before working on the product.

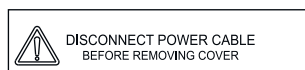

Indicates an electrical shock hazard in case of contact:

- ⇒ disconnect the electrical power supply before removing the cover and working on the product.



Locate a grounding point on the product.



Quality: certifies that the product has been certified compliant with quality control upon leaving the factory.

Pu_GL : 1	Pu_N : 1
Mu_GL : 12856	Mu_N : 31
Mu_Cal : 1	Mu_LDS : 1800

DD-MM-YY^④
Factory Firmware /Logiciel usine
 L0232 V3302 E17D
 L0264 V3200 FD87E7D
 L0285 V3200 8C9D
 ① ② ③

NOTICE
 PUMP IS SHIPPED WITHOUT
 OIL INSTALLED
 Consult operating manual
CAUTION



	Ateliers Busch S.A. Zone Industrielle CH-2906 Chevèvez		Made in France YYYY
	Leak Detector	P/N =	
S/N =	m =		
P =			

For service centers use only.

Indicates the firmware versions installed on the product.

- 1) Firmware name
- 2) Firmware version
- 3) Firmware checksum
- 4) Publication date

Indicates that the primary pump has been drained of oil upon leaving the factory: oil must be added before the first detector switch on (see 5.4)

Product subject to the treatment of waste electronic and electrical equipment in accordance with directive 2012/19/EU.

Product identification label (see 4.1).

2 Safety

2.1 Safety precautions



Obligation to inform

Any person responsible for installing, using or maintaining the product must first read the security instructions in this operating manual and comply with them.

→ It is the operating customer's responsibility to protect all operators against the dangers associated with the product, with the media pumped and with the entire installation.



Installation and use of the accessories

The products can be fitted with special accessories. The installation, use and refurbishment of the connected accessories are described in detail in the respective manuals.

→ Only use original accessories.

→ Accessory part numbers: see **Accessories**.



WARNING

Hazard associated with non-compliant electrical installation

Safe operation after installation is the operator's responsibility.

→ Connect the product to an installation that is compliant with local safety standards.

→ Do not carry out any alterations or modifications to the product on your own initiative.

→ For specific questions, contact your service center.



WARNING

Electric shock hazard in case of contact

When the product's circuit breaker is set at **O**, some internal components still have an electrical charge.

→ Make sure that the mains connection is always visible and accessible so that it can be unplugged at any time.

→ Disconnect the power cable from all power sources before starting any work on the product.



WARNING

Other localized hazardous energies

Electrical circuit and other pressurized circuits as nitrogen are potential hazards:

→ Always lock out these energy sources before working on the product.



WARNING

Risk associated with process gases

A leak detection operation must be carried out under environmental conditions that do not present any risks to the operator and the equipment. The user and/or integrator of the product are fully responsible for the operational safety conditions of the equipment. Therefore the user of the detector must:

→ not test parts or equipment with traces of harsh, chemical, corrosive, inflammable, reactive, toxic, or explosive substances, nor condensable vapours even in small amounts. Do not use the purge system to dilute these hazardous products: that is not what it is intended for!

→ apply specific safety instructions in accordance with local regulations. For more information, contact your service center.



NOTICE

Filling with oil
 → Oil must be added to the primary pump before the detector is switched on.

The potential hazards for a leak detector involve electricity, the tracer gas, the pressurised nitrogen supply and the lubricant.

- Only qualified personnel trained in safety rules (EMC, electrical safety, chemical pollution) may carry out the installation and maintenance described in this manual. Our service centers can provide the necessary training.
- Do not remove the blanked-off flange from the inlet port while the product is not in use.
- Do not expose any part of the human body to the vacuum.
- Comply with all safety and risk prevention instructions in accordance with local safety standards.
- Regularly check compliance with all precautionary measures.
- Do not turn on the product if the covers are not in place.

2.2 Protective equipment

In some situations, personal protective equipment must be worn when handling the detector and its components. Customers must provide operators with the necessary equipment. This equipment must be checked regularly and used in accordance with the supplier's recommendations.



DANGER

Health hazard in case of contact with the operating fluid
 Contact with or inhaling products such as oil from the pump can cause irritation.
 → Wear appropriate protective equipment when carrying out maintenance or adding/draining oil.



WARNING

Risk of injury due to falling objects
 When transporting parts/components and during maintenance there is a danger of loads slipping and falling down.
 → Carry small and medium-size parts/components with both hands.
 → Carry parts/components > 20 kg with a suitable lifting device.
 → Wear safety shoes with a steel toe in accordance with directive EN 347.



WARNING

Risk of injury through hot surfaces
 The products are designed so as not to present a thermal risk for the operator's safety. However, specific operating conditions may exist that require extra caution from users due to the high temperatures (surfaces > 70 °C for parts inside the covers).
 → Leave the part to cool before working on the product.
 → If necessary wear protective gloves according to directive EN 420.



CAUTION

Risk of pinching
 When handling the storage tank cover, there is a risk of fingers becoming pinched.

2.3 Proper use



NOTICE

EC conformity

The manufacturer's declaration of conformity becomes invalid if the operator modifies the original product or installs additional components.

→ Following installation into a plant and before commissioning, the operator must check the entire system for compliance with the valid EU directives and reassess it accordingly.

- The leak detector is designed to detect and/or quantify a possible installation or component leak by searching for the presence of a tracer gas in the pumped gases.
- Only the tracer gases identified in this manual may be used.
- The parts to be tested must be clean and dry.
- The product may be used in an industrial environment.

2.4 Improper use

Improper use will cause all claims for liability and warranties to be forfeited. Improper use is defined as usage for purposes deviating from those mentioned above, especially:

- pumping harsh, chemical, corrosive, inflammable, reactive, toxic or explosive fluids
- pumping of liquids
- pumping of condensing vapors
- pumping dust or solids particules,
- operation in potentially explosive areas
- analysis of gas with a hydrogen concentration higher than 5 %
- testing parts that are soiled or that have traces of water, vapours, paint, adhesive, detergent or rinsing products
- use of accessories or spare parts, which are not named in this manual

The product is not designed to carry people or loads and is not for use as a seat, step-ladder or any other similar purpose.

3 Transport and storage

Upon delivery, check that the product has not been damaged during transport. If the product is damaged, take the necessary measures with the carrier and notify the manufacturer. In all situations we recommend:

- Keeping the product in its original packaging so it stays as clean as it was when dispatched by us. Only unpack the product once it has arrived at the location where it will be used.
- Keeping the packaging (recyclable materials) in case the product needs to be transported or stored.
- Keeping the blanked-off plate on the inlet port when the product is not in use.

3.1 Transport

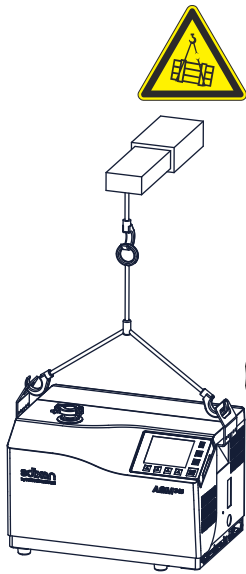

WARNING
<p>Risk of injury associated with heavy loads</p> <p>Given the weight of the product, it should be removed from its packaging only by personnel qualified and trained in handling heavy materials.</p> <ul style="list-style-type: none"> → Use the yellow lifting handles installed on the product (re-install if they have been removed). → The manufacturer cannot be held liable for the consequences of using lifting devices other than those provided.

NOTICE
<p>Work/Handling the detector</p> <p>The operator must not work on the product to move it or carry out maintenance until it has come to a complete shutdown! When the circuit breaker is set at O, you must:</p> <ul style="list-style-type: none"> → Unplug the power cable. → Wait for the control panel screen to turn off completely before working on the product and/or removing the covers.

Before moving a detector, make sure that the covers are properly attached:

- The front cover cancels 3 fixing screws for the rear cover (out of the 5 screws in total): make sure that these 3 screws are in place and properly tightened.
- Make sure that all the fixing screws for the covers on the detector frame (5 screws for the rear cover and 4 for the front cover) are in place and properly tightened.

To lift the product:

- Use a lifting device appropriate for the product's weight.
- Use a 3-section strap with the following characteristics:
 - length of each section > **500 mm**
 - load per section > **350 kg**

3.2 Storage



Storing a new product

NOTICE
<p>Obligation to inform</p> <p>We took care to provide you with a clean product. So that it stays clean, we recommend storing it in its original packaging.</p>



If a new detector must be stored:

- leave it in its packaging,

- leave the blanked-off flange in place on each port,
- store it in a clean, dry environment, in accordance with the temperature conditions specified in the **Technical Characteristics** (see 11.2).

Extended storage

Recommended shutdown procedure before extended storage:

- Place the blanked-off flange on the inlet port.
- In the menu **[Test]**, check:
 - that the 'hard vacuum' test method is selected,
 - that the air inlet valve is set to 'Operator'
- Start a test by pressing  : wait until the detector reaches the most sensitive test mode.
- Make sure that the inlet vent is inactive.
- Stop the test by pressing .
- Shut down the detector: circuit breaker  to **O**.
- Wait for the control panel turn off.
- Unplug the power cable.

In this way, the detector is under a vacuum, reducing the degassing time spent when it is switched on again.

4 Product description

4.1 Product identification

To correctly identify the product when communicating with Busch, always have the information from the rating plate available.

Fig. 1: Nameplate example

1	Manufacturer
2	Date of manufacture
3	Product name
4	Part number
5	Serial number
6	Weight
7	Maximum power consumption
8	Power supply
9	Barcode

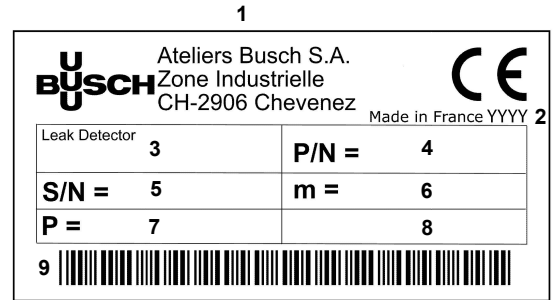

4.1.1 Scope of delivery

- 1 leak detector
- 1 documentation set (operating instruction, plastic coated memos for the detector and the RS-232)
- 1 power cable for Europe (France/Germany) and/or 1 power cable for US
- 2 lifting handles installed on the product
- 1 calibration certificate for the internal calibrated leak
- 1 funnel
- 1 oil can
- 1 draining connector

4.2 Interface connection

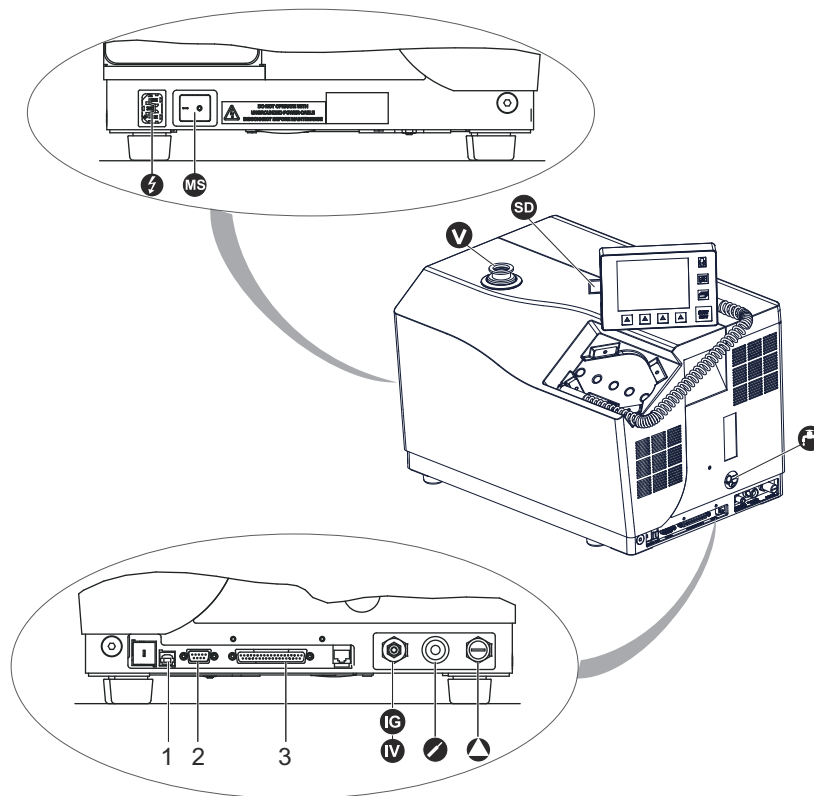

Fig. 2: Human-machine interface

	Mains power supply		SD card
	Detector inlet (Inlet port)		Sniffer probe connection ⁽¹⁾ (STANDARD SNIFFER)
	Primary pump Exhaust (EXHAUST)		Air inlet
	Switch/Circuit breaker	1	USB plug (USB)
	Neutral gas inlet (purge) (VENT/PURGE)	2	RS-232 connector D-Sub 9 pins (SERIAL)
	Oil draining	3	Interface Connector- I/O D-Sub 37 pins (INPUTS/OUTPUTS)

(1) Accessory (at the customer's expense)

4.3 Test methods

4.3.1 Hard vacuum test

- Part that can be connected to pipe and placed under a vacuum.
- Part that can be placed in a vacuum chamber.

Spray method This method involves removing the air from the part to be tested, connecting it to the detector's analyzer cell, then spraying tracer gas on the points of the part that are likely to leak.

The detector measures the flow of tracer gas that penetrates due to part leakage.

When spraying starts, the leak rate is not displayed instantaneously: there is a response time which depends on the volume V being tested and the tracer gas pumping speed S of the system at the opening of the part, according to the following relation:

$$T = V/S \text{ (where } T = \text{seconds, } V = \text{litres, } S = \text{l/s).}$$

T is the time required for the leak rate to reach 63 % of the final value.

4.3.2 Sniffing test mode

- Part that can be connected to pipe and cannot be placed under a vacuum.

The part to be tested is pressurised with tracer gas.

The detector measures the flow of tracer gas that leaks out of the part through a sniffer probe that moves across all the points prone to leaking.

The detector measures the flow of tracer gas that leaks out of the part.

The measured leak rate is not an exact measurement of the leak. The sniffer probe only detects part of the tracer gas escaping from the part, depending on the distance separating the crack from the tip of the probe, and the direction of the leak in relation to the probe.

5 Installation

5.1 Prerequisites for optimising measurement

To optimise pumping and measurement speed:

- Use pipe with a diameter equal to the diameter of the detector's inlet. The pipes should be as short as possible and completely sealed.
- Do not use plastic hoses such as compressed air pipes.
- Check that the connected part/installation is impermeable to tracer gas.
- Test only clean, dry parts/installations with no trace of water, vapour, paint, detergent or rinsing products.
- Test that the entire line is completely sealed when the detector is attached to the pumping circuit, to ensure that the connections are correct (pump, pipe, valves, etc.).

5.2 Operating conditions



DANGER

Explosion hazard.

For detecting leaks with 'hydrogen' tracer gas, the operator must use hydrogenated nitrogen (mix of 95 % N₂ and 5 % H₂).



NOTICE

Risk of pollution from solid substances

When applications generate particles, we recommend protecting the detector's inlet.

→ Install a inlet filter.



NOTICE

Detector ventilation

If there is insufficient ventilation, overheating could cause damage to the components:

→ Comply with the ambient operating temperature.

→ Do not obstruct the air vents.

→ Leave a gap of 70 mm around the air vents.

Environmental conditions (see 11.2).

5.3 Set-up

The leak detector must be installed on a flat, horizontal surface, supported by its feet, with the detector's inlet port on the top.

- Choose the location for set up according to the dimensions of the detector: chapter **Technical Characteristics** (see 11.2).
- Move the detector with a hoist, using the handling devices (see 3.1).

5.3.1 Storing the lifting handles

Once the detector has been installed, the handles can be removed and stored in the back of the detector or used to place the control panel on a work surface.

Tools required • 5-mm Allen key.

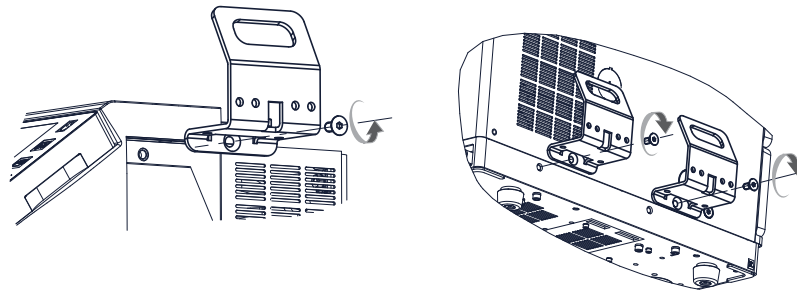

Fig. 3: Storing the lifting handles

5.3.2 Control panel equipment

The control panel can be placed on a work surface using the lifting handles for support.

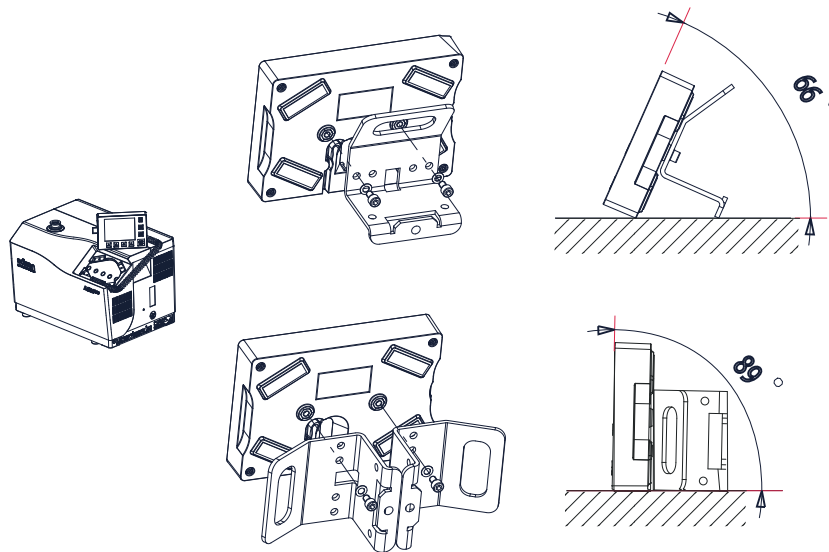

Fig. 4: Control panel on work surface

→ Attach the handles with 2 CHc M6 x 10 screws and 2 \varnothing 6 mm bolts (at customer's expense).

5.4 Filling with oil



DANGER

Health risk in case of oil contact

The pumps are delivered empty of oil: the oil is delivered in separate containers.

→ Wear mask, gloves, protective glasses to fill the pumps with oil.

NOTICE

Only use approved operating fluids

The pumps are factory tested using Busch oil.

→ The same oil **must be used** during operation. The oil safety data sheet is available on the Busch website.

→ Make sure that the detector is off (circuit breaker MS at O , the control panel screen is off) and in a horizontal position.

→ Open the cover.

→ Remove the oil fill cap (1) from the rotary vane pump (2).

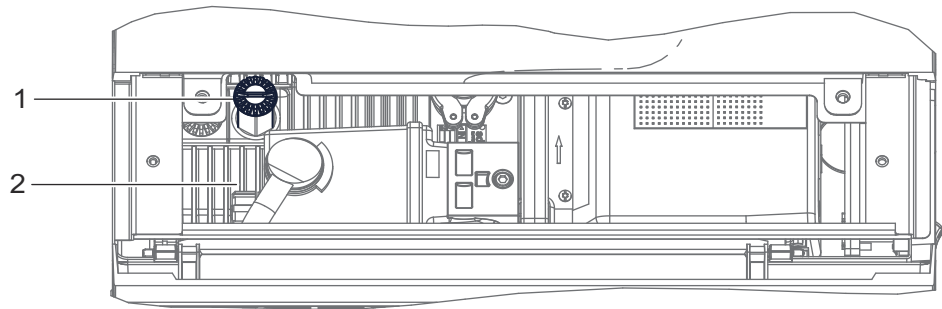

- Put the funnel (included with the detector) in the oil fill opening (3).
- Fill with oil to the highest level.

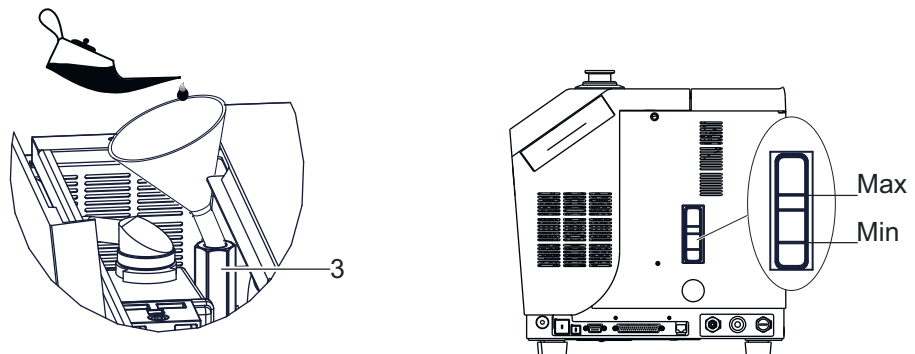

- Replace the oil fill cap tightly (1).

5.5 Connection to the mains power supply



WARNING

Risk of electromagnetic disturbance

The product's EMC behavior is guaranteed only if the relevant EMC standards are followed during installation.

- Use shielded cables and connections for the interfaces in interference-prone environments.



WARNING

Hazard associated with non-compliant electrical installation

Safe operation after installation is the operator's responsibility.

- Connect the product to an installation that is compliant with local safety standards.
- Do not carry out any alterations or modifications to the product on your own initiative.
- For specific questions, contact your service center.

The leak detector is Class 1 equipment and therefore must be earthed.



5.6 Operating for the first time

- Check that the oil level of the primary pump is between the maximum and minimum levels (see 5.4).
- Attach the electrical network to the connector ⚡ using the power cable delivered with the detector.
- Set the circuit breaker Ⓜ to I.
- Set the language, unit, time and date (the operator can modify this at a later time (see 7.7.1)).

→ Wait for the detector to enter Stand-by mode.



5.6.1 Familiarise yourself with the control panel

Control panel description (see 6.1.2).

- Press  several times to familiarise yourself with the application screens.
- Press  several times to see the 2 levels of function keys available.
- For each level, press  or the control panel function key to access the function.

5.6.2 Become familiar with the detector

You can carry out a hard vacuum test and learn about your detector simply by performing a test on the equipment itself.

- Leave the blanked-off flange included with the product in place on the detector's inlet.
- Start a test by pressing . The measured leak rate is displayed: this is the detector's background.
- Stop the test by pressing .
- To remove the blanked-off flange from the detector's inlet, press **[Inlet vent]**.

5.7 Connecting the part/installation to be tested



NOTICE

Limit of operation
 → Make sure that the parts or chambers connected to the inlet of our products withstand a negative pressure of $1 \cdot 10^3$ hPa in relation to atmospheric pressure.

- The inlet pressure must be no higher than atmospheric pressure. Pressure that is too high can damage the product.
 - The detector's performance depends on the type of accessories used and on the quality of the mechanical connections.
 - When assembling the vacuum circuit, use accessories to shut off the product and make maintenance easier (inlet shut off valves, purge systems, etc.).
 - Comply with these recommendations (see 5.1) to optimise measurement.
 - The maximum permitted weight at the detector's inlet must be no more than 15 kg and the maximum torque must be 10 N·m.
- Remove the blanked-off flange that covers the detector's inlet and save it for reuse during storage or transport.
 - Connect the part or the equipment to be tested using the connection accessories available in the product catalogue.
 - Test that the entire line is completely sealed when the detector is attached to the pumping circuit, to ensure that the connections are correct (pump, pipe, valves, etc.).

5.8 Connecting the exhaust



NOTICE

Limit of operation
 → Make sure the exhaust pressure does not exceed 200 hPa (relative). Pressure that is too high can damage the product.



NOTICE

Pumping at high pressure
 → Connect the exhaust to an exhaust duct. 1/8 Gas connection.

The detector's primary pump is equipped with an internal oil mist eliminator.
The operator can connect an external eliminator instead of this internal eliminator.

6 Operation

6.1 Control panel

It is interfaced with the detector and is used to:

- display information about the test
- access the available functions
- setting of the detector's parameters.



For a screenshot, set a function key to [Screen Copy] (see 7.7.2).



If the screen is out of order, functions remain accessible: use RS-232 to pilot/set the detector.

6.1.1 Description

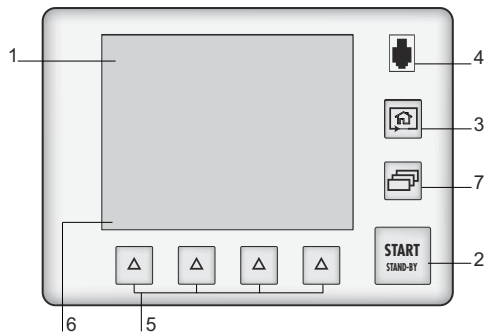









Fig. 5: Control panel

1	Application screens (touch screen): these are accessible or hidden (see 7.7.3).
2	Test Start/Stop.
3	Changing the application screens: return to the home page (standard screen) from any menu.
4	Remote control connection (not available).
5	Quick access to the functions. Functions assigned to a key by the operator (provides access to the functions if there is a problem with the touch screen).
6	Displaying a function key level: starting the function or displaying a sub-menu by touching the screen.
7	Changing the level of function keys.

- ➔ Remove the film that protects the screen upon delivery.
- ➔ Use the touch screen manually without using hard objects such as pens, screwdrivers, etc.

	Function deactivated (OFF)
	Function activated (ON)
	Authorized access without password
	Access locked: access with password
	"Grey" key: access settings or function
	"White" key: key not customisable, for information
	"Measurement information" key: to display the measured leak rate
	Arrows for navigating within the menus

	Access to the error/warning window
	Value selected is customisable
	Keys for setting the values
	Moving to the next function/screen/parameter
	Return to the previous display
	Return to the previous display and confirm the changes made
	Return to the previous display without confirming the changes made
	Deleting the selected file

Set point setting

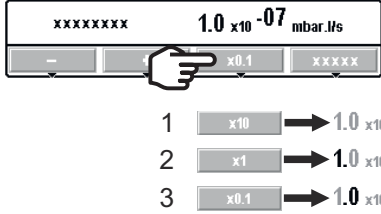

xxxxxxx 1.0 x10⁻⁰⁷ mbar.Hs

1  → 1.0 x10⁻⁰⁷

2  → 1.0 x10⁻⁰⁷

3  → 1.0 x10⁻⁰⁷

1	Exponent setting
2	Mantissa unit setting
3	Mantissa tenth setting

6.1.2 Contrast - Brightness - Screen Saver

(see 7.7.4)

6.1.3 Application screens

The content of the screens is given as an example. Depending on the leak detector and parameters, the display may be different.

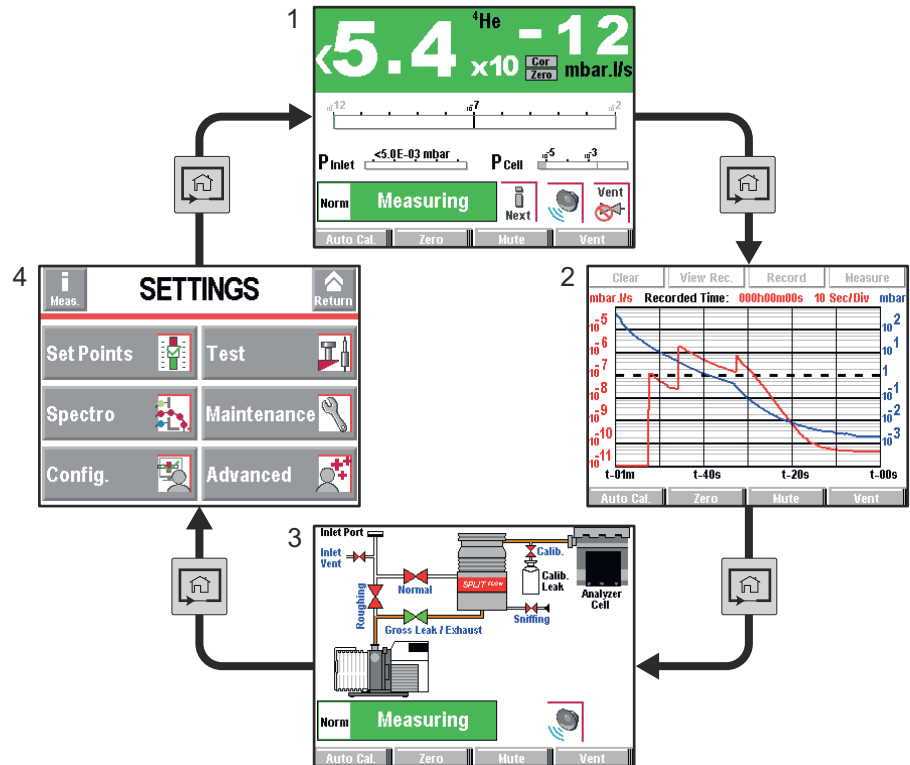

Fig. 6: Example of each screen

1	"Standard" screen (home)
	Information about the current test
2	"Graph" screen
	Monitoring and recording the leak rate and/or the inlet pressure
3	"Vacuum circuit" screen
	Vacuum circuit of the detector and the status of the valves
4	"Settings" screen
	Detector parameters



The operator can hide and/or switch certain screens in the loop (see 7.7.3).

6.1.4 "Standard" screen

Information about the test: display most often shown during a test.

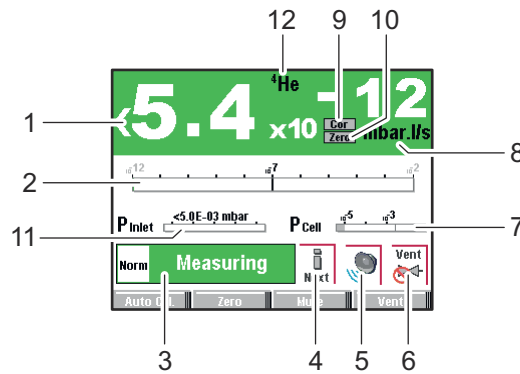

1	Digital display of the leak rate (green \leq reject set point < red)
2	Bargraph display of the leak rate (adjustable scale)
3	Detector status and Detection mode
4	Access error information
5	Mute function indicator
6	Air inlet function indicator (except ASI 30/35)
7	Cell pressure bargraph display
8	Leak detector unit
9	Leak rate correction function indicator
10	Zero function indicator
11	Detector inlet pressure display (unit consistent with the leak rate unit)
12	Tracer gas (^3He , ^4He or H_2)



A password can be used to lock access to the "Settings" menus while leaving certain functions accessible using the function keys (see 7.7.2).

6.1.5 "Settings" screen

Setting the detector's parameters.

The "Settings" screen is accessible from any window, by pressing the following two keys at the same time + .

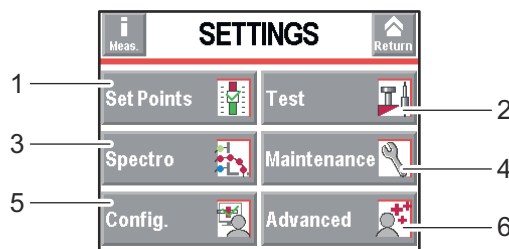

1	Set points setting: reject set point, audio level, digital voice, pollution.
2	Method and test mode selection. Inlet vent management. Correction value. Cycle end.
3	Tracer gas selection. Setting the calibrated leak.
4	Scheduling maintenance
5	Detector setting for the operator: language, unit, password, function keys, application screens.
6	Advanced functions reserved for specific detector uses.

6.1.6 "Graph" screen

Monitoring and recording the leak rate and/or the inlet pressure.

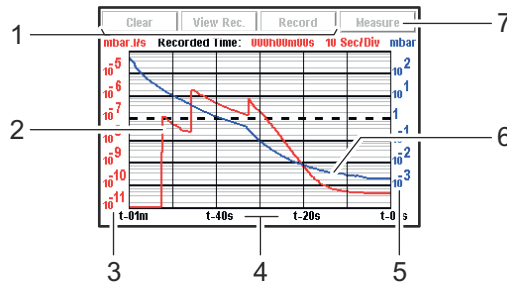

1	Deleting/Viewing/Recording a plot
2	Plot of the tracer gas leak rate (in red)
3	Scale of the tracer gas leak rate (in red)
4	Time scale
5	Inlet pressure scale (in blue)
6	Inlet pressure plot (in blue)
7	Displaying/Hiding the Measurement window (see 6.1.8)

6.1.7 "Vacuum circuit" screen

Vacuum circuit of the detector and the status of the valves.

Vacuum circuit is specific for each leak detector.

The vacuum circuit varies depending on the status of the valves, but does not make it possible to manage the valves.

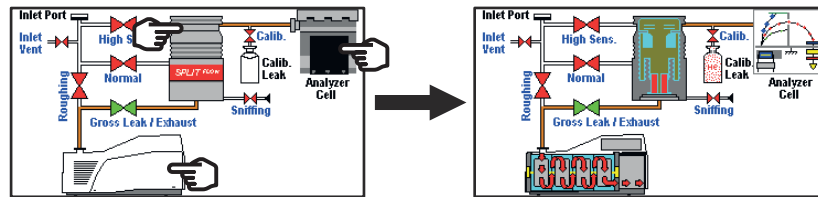

Fig. 7:Example

Red valve	Valve closed
Green valve	Valve open
Pumps, Analyzer cell	⇒ Press the component to display the operating principle.

6.1.8 "Measurement" window

→ Press the **[Measure]** key to display the window.

→ Press and drag the window to move it on the screen.



Fig. 8: [Measure] key and corresponding window

1	Digital display of the leak rate (green ≤ reject set point < red)
2	Detector test mode
3	Error information indicator
4	Zero function indicator
5	Leak rate correction function indicator

6.1.9 Function keys

The function keys are used to activate/stop a function or to set set points (see 7.7.2).

Thanks to the function keys, it is possible to give the operator access to a limited number of functions.

6.2 Prerequisites to use

The leak detector is set to perform a hard vacuum test in the most sensitive test mode according to the initial settings (see 7.2.1).

For use with any other parameters or other functions, see **Chapter 7**.



NOTICE
<p>Risk of seizing</p> <p>→ Never move the detector while it is in use, even if it is placed on a trolley.</p>



NOTICE
<p>Filling with oil</p> <p>→ Oil must be added to the primary pump before the detector is switched on.</p>

Before each switching on:

- Become familiar with the safety instructions (see 2).
- Remove the cover before using the product.
- Check that all the connections are correct (see 5).
- Before use, make sure that the leak detector is in an environment free of tracer gas.
- Check that the electrical network is properly attached to the connector ⚡ using the power cable.
- Check that the oil level of the primary pump is between the maximum and minimum levels (see 5.4).

6.3 Switching the detector on

6.3.1 Switch on

- Set the circuit breaker  to I (see 4.2).

The various stages for switching the detector on are displayed. The detector is ready for testing when the Stand-by screen appears.

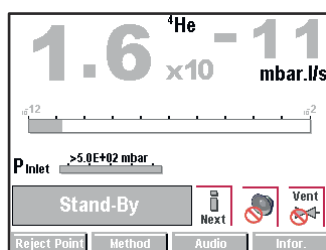

Fig. 9: Stand-by screen

Switching the detector on for the first time

(see 5.6)

Switching on after an extended shutdown

If the detector has been stored or has not been used, switching on time will be longer than if it is in regular use.

6.3.2 Starting a test

Hard vacuum test

- Select the 'hard vacuum' test method (see 7.4.1).
- Set the test mode (see 4.3.1).



- Set the reject set point if necessary (see 7.3.3).
- Set the detector to Stand-by mode.
- Prepare the part to be tested.
 - Spray method
 - Remove the air from the part to be tested
 - Connect the part to be tested to the leak detector inlet port.
- Start a test by pressing  .
 - Spray method
 - Spray tracer gas on the points of the part that are likely to leak.

The various test stages are displayed.

- When the detector has reached the most sensitive test mode, wait for the measurement to stabilise: the measurement displayed corresponds to the measured leak rate.
- Stop the test by pressing  .

The test can also be started using a remote control (accessory): see *Remote control Operating instructions*.

Sniffing test

- Set the reject set point **if necessary**(see 7.3.4) .
- With the leak detector in Stand-by mode, connect the sniffing probe (accessory) to the provided connector ().
- Start a test by pressing  .
- Slowly scan, with the sniffer probe, the areas of the part to be tested with potential leak: the displayed leak rate varies in presence of a detected leak (qualitative value of the measured leak rate).
- Stop the test by pressing  .

6.4 Monitoring operation

When the detector is in use, the operator is alerted to incidents as follows:

- Pictogramme display indicating that the error message should be read.
- Error display on the screen.

Message list: see **List of warnings/faults** in *Maintenance instructions*.

6.5 Shutdown the detector

- Set the circuit breaker  to **O** (see 4.2).
- Wait for the control panel screen to turn off completely before working on the product, removing the covers and/or moving it.

Shutdown due to a mains power failure

When there is a mains power failure, the detector shuts down: it switches on again automatically when power is restored.

6.6 Saving and downloading the product's configuration

When a detector is installed or replaced, it is helpful to copy the configuration (all the parameters and operating set points programmed by the operator) of a detector that is the same model.

- Do this while the detector is switched on and in Stand-by mode.

6.6.1 Saving the configuration

- Follow the procedure for saving (see 7.8.12).

The detector's configuration will be saved on the SD card from control panel.

6.6.2 Downloading the configuration

→ Follow the procedure for downloading (see 7.8.12).

The previous configuration is automatically updated.

All the detector's parameters are downloaded except the following, which must be set by the operator:

- language
- serial link
- time and date
- temperature unit
- pressure unit.

7 Advanced settings

7.1 "Graph" screen

→ Access the "Graph" screen by pressing .

7.1.1 Description

Monitoring and recording the leak rate and/or the inlet pressure.

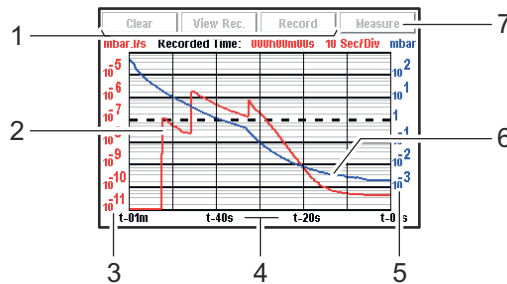

Fig. 10: "Graph" screen

1	Deleting/Viewing/Recording a plot
2	Plot of the tracer gas leak rate (in red)
3	Scale of the tracer gas leak rate (in red)
4	Time scale
5	Inlet pressure scale (in blue)
6	Inlet pressure plot (in blue)
7	Displaying/Hiding the measurement (see 6.1.8)

Scales (3), (4), (5) are adjustable by pressing the graph.

7.1.2 Settings

→ Access the graph settings menu by pressing the graph.

Display

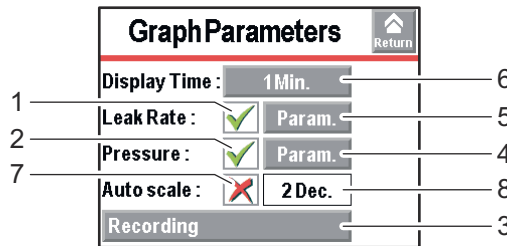

1	Displaying/Hiding the measured leak rate
2	Displaying/Hiding the inlet pressure
3	Setting the recording time
4	Setting the inlet pressure scale
5	Setting the leak rate scale (If 'automatic' scale is deactivated)
6	Screen scroll speed
7	Activating/Deactivating the automatic scale
8	Setting the automatic scale

Automatic scale

The automatic scale is used to display the measured leak rate centred on 2 or 4 decades. The scale varies according to the leak rate measured. When the automatic scale is activated, the scales set for the leak rate and pressure are no longer taken into account.

Example: leak rate = $5 \cdot 10^{-8}$ Pa·m³/s ($5 \cdot 10^{-7}$ mbar·l/s)

- automatic scale 2 decades: scale from $1 \cdot 10^{-7}$ to $1 \cdot 10^{-9}$ Pa·m³/s ($1 \cdot 10^{-6}$ to $1 \cdot 10^{-8}$ mbar·l/s)

- automatic scale 4 decades: scale from $1 \cdot 10^{-6}$ to $1 \cdot 10^{-10}$ Pa·m³/s
($1 \cdot 10^{-5}$ to $1 \cdot 10^{-9}$ mbar·l/s)

Recording → Press **[Recording]**.

Duration	Recording duration	
Capacity	Total recording time according to recording duration	
Duration	Maximum capacity	File size
0.2 s (min.)	6 hours 33 minutes	≈ 7 Mo
30 s (max.)	983 hours	

7.1.3 Recording

Recording makes it possible to store the measurements taken during the test in the control panel memory: **it will not save these measurements** (see 7.1.6).

During a recording, all the detector functions are available.

After the detector is switched off (cut off at the mains or by the operator), the recordings already made are stored in the memory. For the next recording, the operator will have to specify:

- if the new recording is to be added to the recordings in the memory **[OK]**
- if the new recording is to delete or replace the recordings in the memory **[Cancel]**.

→ Change the recording parameters if necessary.

→ Press **[Record]** (1) (see 7.1.1) to start recording

None of the measurements displayed on the plot before the recording starts will be recorded.

→ Press **[Stop]** (1) to stop recording.

→ Press **[View Rec.]** (1) to see the recording.

If the memory is not cleared between two recordings (**[Clear]** (1)), all subsequent recordings will appear consecutively on the same memorised plot. A ▲ cursor indicates the end of each recording.

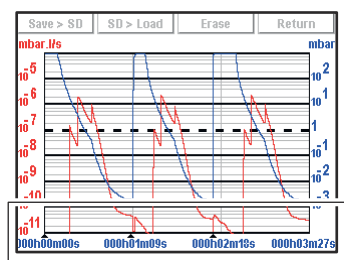

Fig. 11: Recording example

1	1 st recording
2	2 nd recording
3	3 rd recording

When the memory is full and if a recording is in progress, recording is automatically stopped.

The **[Record]** key is replaced by the **[Mem full]**.

7.1.4 Graph clearing

Current window → Display the "Graph" screen (see 7.1.1).

→ Press **[Clear]** (1) and validate the message.

Clearing the current window does not delete the current recording or recordings already made.

- Recording**
- Display the "Graph" screen (see 7.1.1).
 - Press **[View Rec.]** (1).
 - Press **[Clear]** (1) and validate the message.

If the detector is carrying out a test while the previous recording is being deleted, the test is stopped.

7.1.5 Viewing a recording



At any time, the operator can view the recording already made or zoom in on a recording, without stopping the current recording.

- Press **[View Rec.]** to view the recording made since the last recording was deleted (1) (see 7.1.1).

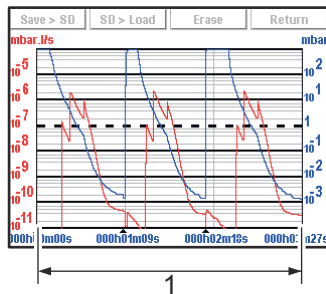

Fig. 12: Viewing a recording

1 | Total recording time

If no plots have been made, the message "Memory empty" is displayed.

- Zoom in**
- Zoom in available only for a recording.
- Press **[View Rec.]** (1) (see 7.1.1).
 - Set the area to be enlarged ((1) then (2)).

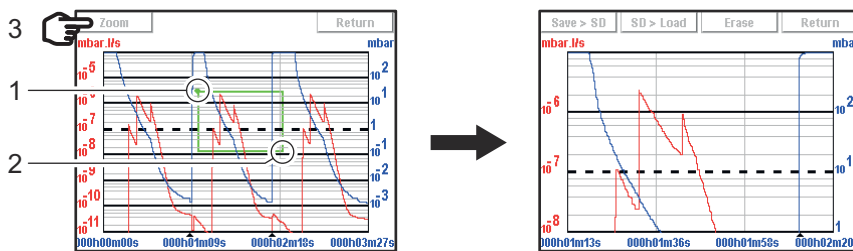

Fig. 13: Selection and viewing the area to be enlarged

- Press **[Zoom]** (3): the enlarged area is displayed.

Several successive zooms are possible (except in the same decade).



If necessary, adjust the area to be enlarged by dragging the corners or sides with your finger.

- Zoom out**
- Zoom out available only for a recording.
- Set the area to be reduced ((1) then (2)): return to the original graph.

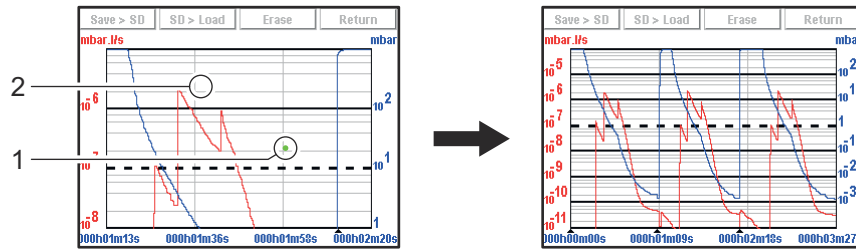

Fig. 14: Return to the original graph

Measurement

Exact measurement of a point only available on a recording.

➔ Select the point to measure (2).

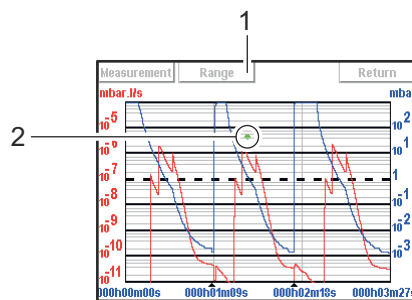

Fig. 15: Example of the recording of a point

- | | |
|---|---|
| 1 | Modifying the leak rate and inlet pressure scales |
| 2 | Point selected |

➔ Press **[Measure]**: the exact measurement of the selected point is displayed.

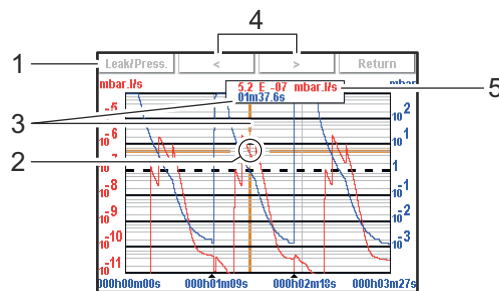

Fig. 16: Exact measurement of the selected point

- | | |
|---|--|
| 1 | Selecting the display of the leak rate or the inlet pressure |
| 2 | Marker indicating the selected point |
| 3 | Moment the measurement took place in relation to the start of the recording |
| 4 | Navigation between next/previous recorded points |
| 5 | Displaying the tracer gas leak rate (in red) or the inlet pressure (in blue) |



To make the exact values of all measurements available on any type of spreadsheet, save the recording to a .txt file.

7.1.6 Saving a recording

This function is used to save the most recent recording on a SD card to be played back/ analysed later on a PC. Saving is not automatic.

It is possible to save a screenshot of the recording (.bmp) or to generate a file (.txt) with all the measurements taken. The .txt file can be used with any spreadsheet (e.g. Excel Microsoft® Office): the default separator is "tab".

→ Press **[Save > SD]** (see 7.1.1).

→ Name the file and save it

The saved .bmp and .txt files include only the measurement points displayed on the screen:

- to include all points, you must be positioned on the relevant plot (without zooming).
- if a zoom was carried out before saving, the zoom will apply only to the points of the selected zone.

If the saved recording is made up of several consecutive recordings:



- the ▲ cursor will indicate each new recording on the .bmp files.
- "B.P. # xx" will be noted at the end of the last line of each recording in the .txt files.

.bmp files can be displayed on the control panel screen.

.txt files can be opened only from a PC.

7.2 Settings

Screen for accessing the detector's settings menus to set the detector according the application. After this, for daily operation the functions keys will be used.

The "Settings" menu is accessible from any screen by pressing 2 keys  +  on the control panel simultaneously.

Access to the various menus can be locked (see 7.7.5).

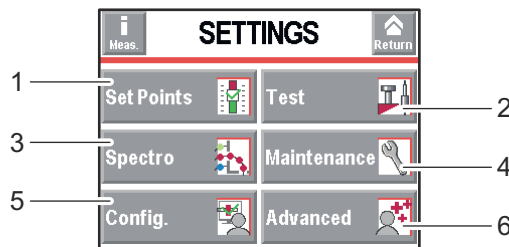

1	Setting the set points: reject set point, audio level, digital voice, pollution.
2	Method and test mode selection. Inlet vent management. Correction value. Cycle end.
3	Tracer gas selection. Setting the calibrated leak.
4	Scheduling maintenance. Detector information
5	Detector setting for the operator: language, unit, password, function keys, application screens.
6	Advanced functions* reserved for specific detector uses.

Table 1:* advanced settings requiring substantial knowledge about leak detection: pressure gauge, etc.

7.2.1 Tree diagram of the "Settings" menus

The following table shows the detector's initial settings. When the detector is off, values and parameters are saved for the next use.

The operator can save and download different leak detector configurations (see 7.8.12).

SET POINTS			
Selection		Choice - Setting limit	Initial settings
Audio	Status	Invalid / Valid	Valid
	Setting (If valid)	1 - 9	3

SET POINTS				
Selection			Choice - Setting limit	Initial settings
Digital voice	Status		Invalid / Valid	Valid
	Setting (If valid)		1 - 9	4
Pollution	Status		Invalid / Valid	Invalid
	Setting (If valid)		$1 \cdot 10^{+19}$ - $1 \cdot 10^{-19}$	$1 \cdot 10^{-05}$
Hard Vacuum Set Points	Reject Point		$1 \cdot 10^{+06}$ - $1 \cdot 10^{-13}$	$1 \cdot 10^{-08}$
	Reject Point 2 (If I/O 37 pins)		$1 \cdot 10^{+19}$ - $1 \cdot 10^{-19}$	$1 \cdot 10^{-07}$
	Reject Point 3 (If I/O 37 pins)		$1 \cdot 10^{+19}$ - $1 \cdot 10^{-19}$	$1 \cdot 10^{-07}$
	Reject Point 4 (If I/O 37 pins)		$1 \cdot 10^{+19}$ - $1 \cdot 10^{-19}$	$1 \cdot 10^{-07}$
	Reject Point 5 (If I/O 37 pins)		$1 \cdot 10^{+19}$ - $1 \cdot 10^{-19}$	$1 \cdot 10^{-07}$
Sniffer set Points	Reject Point		$1 \cdot 10^{+06}$ - $1 \cdot 10^{-12}$	$1 \cdot 10^{-04}$
	Probe Clogged		$1 \cdot 10^{+19}$ - $1 \cdot 10^{-19}$	$1 \cdot 10^{-06}$

TEST					
Selection			Choice - Setting limit	Initial settings	
Method			Hard Vacuum / Sniffer	Hard Vacuum	
HV Correction	Status		Invalid / Valid	Invalid	
	Setting (If valid)		$1 \cdot 10^{+20}$ - $1 \cdot 10^{-20}$	$1 \cdot 10^{+0}$	
Mode	(If hard vacuum test method)		Gross leak / Normal	Normal	
Probe Type	(If sniffer test method)		Standard	Standard	
Cycle End	Automatic cycle end		Operator / Automatic	Operator	
	Setting (If automatic)	Roughing Timer	Status	Invalid / Valid	Valid
		Setting	Setting	0 - 1 h	10 s
Test Timer			0 - 1 h	10 s	
Inlet Vent	Inlet Vent		Operator / Automatic	Operator	
	Delay		0 - 2 s	0 s	
	Vent Timer	Status	Invalid / Valid	Invalid	
Setting (If automatic)			0 - 1 h	9 s	
Memo Function	Active		Non / Oui	Non	
	Display Time	Status	Invalid / Valid	Invalid	
Setting (If automatic)			0 - 1 h	10 s	
Zero activation	Activation		None / Operator / Automatic	Operator	
	Zero Exit (if operator)		Press once / Press > 3 s	Press once	
	Value (If automatic)	Trigger		Timer / Set point	Timer
Setting		If Timer	0 - 1 h	10 s	
		If Set Point	$1 \cdot 10^{+19}$ - $1 \cdot 10^{-19}$	$5 \cdot 10^{-7}$	
Regeneration	Function launching		-	-	
Massive Mode	Active		No / Yes	Yes	
	Sensitivity		High / Low	High	

SPECTRO				
Selection			Choice - setting limit	Initial settings
Tracer Gas			Helium 4 / Helium 3 / Hydrogen	Helium 4
Filament selected			1 / 2	1
Filament			Off / On	On
Filament Status			0 - 100 %	100 %

Advanced settings

SPECTRO				
Selection		Choice - setting limit	Initial settings	
Calibrated Leak	Tracer Gas		Helium 4 / Helium 3 / Hydrogen	Helium 4
	Type		Internal / External	Internal
	Unit		mbar·l/s / Pa·m ³ /s / Torr·l/s / atm.cc/s / ppm	mbar·l/s
	Leak Value		-	Refer to certificate delivered with the detector
	Calibration valve		Closed / open	Closed
	Loss Per Year (%)		0 - 99	6
	Reference Temperature (°C)		0 - 99	23
	Temperature Coefficient (%/°C)		0.0 - 9.9	3.0
	Year		-	Refer to certificate delivered with the detector
	Internal Temperature (°C) (If type = internal) External Temperature (°C) (If type = external)		-	-

MAINTENANCE					
Selection		Choice - Setting limit	Initial settings		
Detector		-	20		
Timers	Detector		-	20	
	Filament 1	Timer		-	20
		Reset Timer	Function launching	-	-
	Filament 2	Timer		-	0
		Reset Timer	Function launching	-	-
	Calibrated leak		-	To be set	
	Cycle Counter	Cycle Counter		-	0
		Time interval		$1 \cdot 10^{+19} - 1$	$5 \cdot 10^5$
		Reset counter	Function launching	-	-
	Primary Pump	Timer (h)		-	20
		Time interval (h)		0 - 99999	8600
		Reset Timer	Function launching	-	-
	Secondary Pump 1	Timer (h)		-	20
		Time interval (h)		-	17200
Reset Timer		Function launching	-	-	
Speed (rpm)		-	-		
Detector Information	Access to Detector general information		-	-	
Pump Information	Secondary Pump 1	Status		-	On
		Rotation		-	Synchro
		Speed (rpm)		-	90000
		TMP information	Access to Pump general information	-	-
Events History		-	Empty		
Calibration History		-	Empty		
Burn-in	Function launching		-	-	
Maintenance Secondary Pump and Cell	Function launching		-	-	

CONFIGURATION					
Selection			Choice - Setting limit	Initial settings	
Unit/Date/Time/Language	Unit		mbar·l/s / Pa·m ³ /s / Torr·l/s / atm·cc/s / ppm / sccm / sccs	To set	
	Date		mm/dd/yyyy	To set	
	Time		hh:mm:ss	To set	
	Language		English / French / German / Italian / Chinese / Japanese / Korean / Spanish / Russian	To set	
Function keys	Setting		-	-	
Application Windows	Standard Window Parameters	Bargraph leak rate	Zoom on Set Point	No / Yes	No
			Low Decade	$1 \cdot 10^{+5} - 1 \cdot 10^{-13}$	$1 \cdot 10^{-12}$
			High Decade	$1 \cdot 10^{+0} - 1 \cdot 10^{-12}$	$1 \cdot 10^{-2}$
		Stand-By Value		Hide / Show	Show
		Inlet Pressure		Hide / Show	Show
	Extra Pressure		Hide / Show	Hide	
	Lower Display Limit		$1 \cdot 10^{+19} - 1 \cdot 10^{-19}$	$1 \cdot 10^{-13}$	
	Standard	Access		-	Show
		Order		-	1 st
	Graph	Access		Hide / Show	Show
		Order (If Show)		2 nd - 4 th	2 nd
	Synoptique	Access		Hide / Show	Show
		Order (If Show)		2 nd - 4 th	3 rd
Settings	Access		Hide / Show	Show	
	Order (If Show)		2 nd - 4 th	4 th	
Screen settings	Brightness		High / Low	High	
	Contrast		0 - 100	50	
	Panel Off		None / 15 min / 30 min / 1 h / 2 h / 4 h	None	
	Paging Function	Without wireless remote control detected		-	None
		With wirelessremote control detected		Off / On	Off
	Reset panel parameters	Function launching		-	-

Advanced settings

CONFIGURATION			
Selection		Choice - Setting limit	Initial settings
Access / Password	Password	0000 - 9999	5555
	Set Points Menu Access	Lock / Unlock	Unlock
	Test Menu Access	Lock / Unlock	Unlock
	Spectro Menu Access	Lock / Unlock	Unlock
	Maintenance Menu Access	Lock / Unlock	Unlock
	Configuration Menu Access	Lock / Unlock	Unlock
	Advanced Menu Access	Lock / Unlock	Unlock
	User Level	Restricted / Medium Access / Full Access	Full Access
Change Password		0000 - 9999	

ADVANCED						
Selection		Choice - Setting limit	Initial settings			
Leak Detection	Start Up Timer		0 - 1 h	10 s		
	Background Suppression	Activation	Off / On	On		
		Crossover Pressures	Gross Leak	$2,5 \cdot 10^{+1} - 1 \cdot 10^{+1}$	$2,5 \cdot 10^{+1}$	
	Calibration	Normal		$5 \cdot 10^{-1} - 1 \cdot 10^{-1}$	$5 \cdot 10^{-1}$	
		Calibration		Operator / Start-Up / Manual	Operator	
		Calibration checking	Checking		Operator / Automatic	Operator
			Frequency (If automatic)	Cycles Hours	0 - 9999 0 - 9999	50 10
	Analyzer Cell	Filament Selected		1 / 2	1	
		Filament		Off / On	On	
		Triode Pression		-	-	
		Electric Zero		-	-	
		Calibration Valve		-	Closed	
		Target Value		-	-	
		Acceleration Voltage (V)		-	-	
		Emission (mA)		-	-	
		Sensitivity Coefficient		-	-	
	Internal Temperature (°C)		-	-		
Internal Pirani Calibration	Function launching		-	-		
External Gauge	Gauge		None / TPR / PCR / Linear	None		
	External Pressure (mbar)		-	-		
	Pression Inlet Source		Internal / External	Internal		
	Full scale (mbar) (if Linear)		0.1 - 50000	To set		
Purge Valve		-	Closed			

ADVANCED						
Selection				Choice - Setting limit	Initial settings	
Input/Output (I/O 15 pins)	Serial link 1	Type			Serial	Serial
		Parameters	Mode	Basic / Spreadsheet / Advanced / Export. Data / RC 500 WL / PV Protocol / Ext. Module		Advanced
			Handshake	None / XON / XOFF		None
		Power Pin 9	-		5 V	
	Serial link 2	Type			Not used / Bluetooth	Not used
		Parameters (If Bluetooth)	Mode	Basic / Spreadsheet / Advanced / Export. Data / PV Protocol		Advanced
			Handshake	None / XON / XOFF		None
	I/O Connector	Analog Output	9-gnd	Allocation	See Manual I/O 15 pins	Mantissa
				Value	According to Allocation	-
			10-gnd	Allocation	See Manual I/O 15 pins	Logarithmic
				Value	According to Allocation	10^{-12}
			12-gnd	Allocation	-	Exponent
Value				$10^{+2} - 10^{-13}$	10^{-12}	
Input/Output (I/O 37 pins)	Serial link 1	Type			Serial / USB	Serial
		Parameters	Mode	Basic / Spreadsheet / Advanced / Data export / RC 500 WL / PV Protocol / Module Ext.		Advanced
			Handshake	None / XON / XOFF		None
			Power Pin 9	-		5 V

ADVANCED Selection						Choice - Setting limit	Initial settings
Input/Output (I/O 37 pins)	Serial link 2	Type			Not used / USB / Bluetooth / Network	USB	
		Parameters	Mode		Basic / Spreadsheet / Advanced / Export. Data / PV Protocol	Advanced	
Handshake			None / XON / XOFF	None			
I/O Connector	Quick View	I/O set in the 37 pins connector					
	Analog output	37-gnd	Allocation	See Manual I/O 37 pins	Mantissa		
			Value	According to allocation	-		
		36-gnd	Allocation	See Manual I/O 37 pins	Logarithmic		
			Value	According to allocation	10 ⁻¹²		
		19-gnd	Allocation	-	Exponent		
			Value	10 ⁺² - 10 ⁻¹³	10 ⁻¹²		
	Digital input	11-gnd	Allocation	See Manual I/O 37 pins	Inlet Vent		
			Activation	Rising edge / Falling edge / Impulsion	Rising edge		
		30-gnd	Allocation	See Manual I/O 37 pins	Zero		
			Activation	Rising edge / Falling edge / Impulsion	Rising edge		
		12-gnd	Allocation	See Manual I/O 37 pins	Calibration		
			Activation	Rising edge / Falling edge / Impulsion	Impulsion		
		31-gnd	Allocation	See Manual I/O 37 pins	Filament		
			Activation	Rising edge / Falling edge / Impulsion	Rising edge		
		13-gnd	Allocation	See Manual I/O 37 pins	HV test		
			Activation	Rising edge / Falling edge / Impulsion	Rising edge		
		32-gnd	Allocation	See Manual I/O 37 pins	- (I/O not used)		
			Activation	Rising edge / Falling edge / Impulsion	Rising edge		

ADVANCED							
Selection					Choice - Setting limit	Initial settings	
Input/Output (I/O 37 pins)	I/O connector	Digital Transistor Output	9 - 28	Allocation	See Manual I/O 37 pins	-(I/O not used)	
				Activation	NO / NC	NO	
			8 - 27	Allocation	See Manual I/O 37 pins	Detector Ready	
				Activation	NO / NC	NO	
			7 - 26	Allocation	See Manual I/O 37 pins	Filament #2	
				Activation	NO / NC	NO	
			6 - 25	Allocation	See Manual I/O 37 pins	Warning/Error	
				Activation	NO / NC	NO	
			Digital Relay Output	5 - 24	Allocation	See Manual I/O 37 pins	GL Test
					Activation	NO / NC	NO
				4 - 23	Allocation	See Manual I/O 37 pins	N Test
					Activation	NO / NC	NO
		3 - 22		Allocation	See Manual I/O 37 pins	Filament on	
				Activation	NO / NC	NO	
		2 - 21		Allocation	See Manual I/O 37 pins	Reject point	
				Activation	NO / NC	NO	
		1 - 20	Allocation	See Manual I/O 37 pins	HV test		
			Activation	NO / NC	NO		
		Select Default Configuration	Function launching		-	-	
		Other Configurations			-(Not used)	-	
		Load Config. from SD Card	Function launching		-	-	
SD Card	Load LD Parameter	Function launching		-	-		
	Save LD Parameter	Function launching		-	-		
	Visualize *.BMP	Function launching		-	-		
SAV	Access to Menu Service with password. Only for Service Centers.						

7.3 Set points Menu

→ From the "Settings" screen, press **[Set points]** to access the menu.

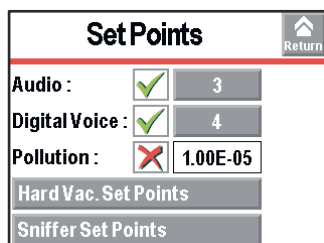

7.3.1 Audio alarm and digital voice

Audio alarm The audio alarm informs the operator that the reject set point has been crossed. The level varies from 0 to 8 (0 to 90 dB (A)).

From the "Settings" screen, press [Set points].

Audio	⇒ Activate the audio level.
	⇒ Set the audio level.



For quick access from the control panel, set a function key to [Audio] (see 7.7.2).



Fig. 17: "Audio" screen using a function key

Digital voice Digital voice informs the operator about the status of the detector or actions to be carried out.

From the "Settings" screen, press [Set points].

Digital voice	⇒ Activate digital voice.
	⇒ Set the digital voice level.



For quick access from the control panel, set a function key for [Voice] (see 7.7.2).

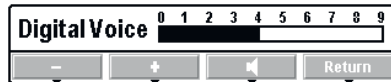

Fig. 18: "Voice" screen using a function key

"Mute" function → Stop the audio alarm and the digital voice at the same time with the [Mute].



To launch the function from the control panel, set a function key to [Mute] (see 7.7.2).

7.3.2 Pollution function

This is a safety device for the detector. It prevents too much leaked tracer gas from penetrating the detector. We recommend setting the pollution set point to a maximum of 4 decades above the reject set point. If the leak rate rapidly increases above the pollution set point, the cycle stops automatically and the leak detector returns to Stand-by mode.

From the "Settings" screen, press [Set points].

Pollution	⇒ Activate the function.
	⇒ Set the application set point.



Useful function if the part or installation to be tested is likely to have gross leaks.

In case of high background noise due to pollution (see 7.4.8).

7.3.3 Hard Vacuum reject point

The hard vacuum reject point defines the acceptance set point for parts that are "accepted/rejected" in a hard vacuum test:

- Measured leak rate ≤ reject set point: part accepted
- Measured leak rate > reject set point: part rejected

From the "Settings" screen, press [Set points] [Hard Vacuum set points].

Reject point	⇒ Set the reject point value.
Reject point #	4 additional reject points available with the 37 pin I/O board.
	⇒ Set the set point value.

The reject set point is memorized for each configurable tracer gas.



For quick access from the control panel, set a function key for [Reject Point] (see 7.7.2).



Fig. 19: "Reject point" screen using a function key.

7.3.4 Sniffing reject set point

The sniffing reject set point defines the acceptance set point for parts that are "accepted/rejected" in a sniffing test:

- Measured leak rate \leq reject set point: part accepted
- Measured leak rate $>$ reject set point: part rejected.

From the "Settings" screen, press [Set Points] [Sniffing Set Points].

Reject point \Rightarrow Set the set point value.



For quick access from the control panel, set a function key for [Reject Set Point] (see 7.7.2) and (see 7.3.3).

7.3.5 Probe clogged set point

The purpose of this set point is to check that the sniffer probe (accessory) is operational. When the measured leak rate is lower than the set 'probe clogged' set point, the operator receives a message to check the probe (See **Sniffer probe Operating instructions**).

From the "Settings" screen, press [Set Points] [Sniffing Set Points].

Probe clogged \Rightarrow Set the set point value.

- The set point unit is the unit set for the detector.
- \rightarrow Block the end of the sniffer probe from time to time with your finger to check that the leak rate is going down. If not, the probe may be clogged or drilled. Do not block the end for too long: if it is the case, a error message displays.

7.4 “Test” Menu

→ From the "Settings" screen, press [Test].

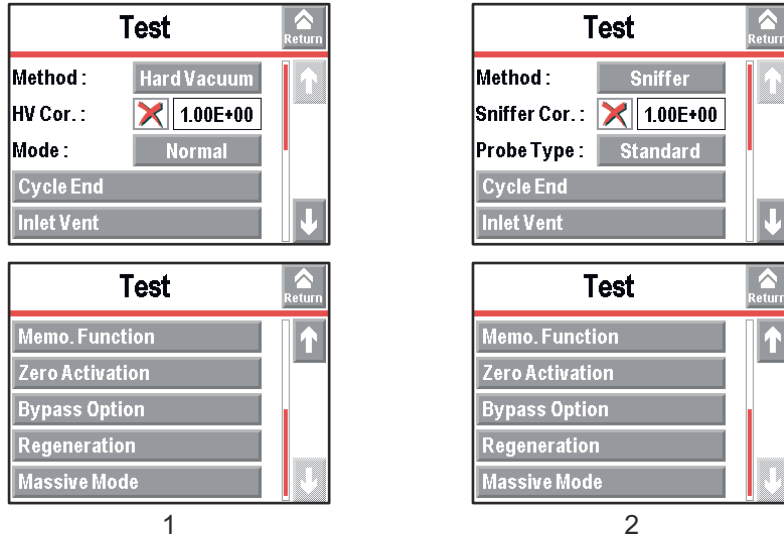

Fig. 20: Hard vacuum test 1 and sniffing test 2 menu

7.4.1 Test methods

There are 2 possible test methods (see 4.3):

- hard vacuum test,
- sniffing test.

From the "Settings" screen, press [Test].

Method	⇒ Select the test method. – For the hard vacuum test, set the test mode (see 7.4.3). – For the sniffing test, set the sniffing probe model used.
--------	--

Switching from 'Hard Vacuum test' to 'Sniffing test'

After modifying the settings, a transition duration of < 3 min during which the test can be performed but calibration is not possible.

Switching from 'Sniffing test' to 'Hard Vacuum test'

After modifying the settings, a transition duration of 30 s during which neither the test nor the calibration can be performed.



NOTICE

Limit of operation

→ Make sure that the parts or chambers connected to the inlet of our products withstand a negative pressure of $1 \cdot 10^3$ hPa in relation to atmospheric pressure.

For quick access from the control panel, set a function key for [Method] (see 7.7.2).



Fig. 21: "Method" screen using a function key

7.4.2 Correction factor

The correction factor allows correction of the measured leak rate by the detector when it is combined with parallel pumping.

From the "Settings" screen, press [Test].

HV Correction/Sniff. Correction	⇒ Activate the correction factor application. ⇒ Set the correction factor to be applied.
---------------------------------	---



For quick access from the control panel, set a function key for [Correction] (see 7.7.2).



Fig. 22: "Correction" screen using a function key

Displays: digital and bargraph

Only the digital display is corrected by the correction factor: the correction factor does not apply to the bargraph display.



Depending on the concentration of tracer gas used for detecting leaks, the leak rate displayed changes.

– Example: the leak rate displayed with a calibrated leak of $1 \cdot 10^{-8}$ Pa·m³/s ($1 \cdot 10^{-7}$ mbar·l/s) (with 100 % ⁴He) connected to the detector's inlet.

% He in the gas used	100 %	50 %	5 %	1%
leak rate displayed on the leak detector without correction	$1 \cdot 10^{-8}$ Pa·m ³ /s $1 \cdot 10^{-7}$ mbar·l/s	$5 \cdot 10^{-9}$ Pa·m ³ /s $5 \cdot 10^{-8}$ mbar·l/s	$5 \cdot 10^{-10}$ Pa·m ³ /s $5 \cdot 10^{-9}$ mbar·l/s	$1 \cdot 10^{-10}$ Pa·m ³ /s $1 \cdot 10^{-9}$ mbar·l/s
Correction value	1	2	20	100
Leak rate displayed on the leak detector with correction	$1 \cdot 10^{-8}$ Pa·m ³ /s $1 \cdot 10^{-7}$ mbar·l/s			

7.4.3 Test mode

A hard vacuum test can be performed as soon as one of the test modes is reached.

The leak detector will automatically switch to the test mode selected when the internal pressure reaches the crossover threshold (see 7.8.4).



For quick access from the control panel, set a function key for [Mode] (see 7.7.2).



Fig. 23: "Mode" screen using a function key



By default, the leak detector is set to work in a hard vacuum test, in the most sensitive test mode: this setting meets the majority of the operators' needs.

From the "Settings" screen, press [Test].

Mode	⇒ Set the test mode.
------	----------------------

7.4.4 Automatic Cycle End

This function allows automatic control of the roughing time and measurement time in a hard vacuum test.

From the "Settings" screen, press [Test] [Cycle End].

Automatic cycle end	⇒ Activate the function. Function activated if 'automatic' is set.
---------------------	---

From the "Settings" screen, press [Test] [Cycle End].	
Roughing timer	Setting optional if 'automatic' is set. ⇒ Activate the control for the roughing duration. ⇒ Set the maximum roughing duration allowed. If the control is activated and the duration expires (detector still in roughing) = part rejected.
Test timer	Setting required if 'automatic' is set. ⇒ Set the measurement duration. When the duration expires, the measured leak rate is displayed.



Function to use to automate small production.

7.4.5 Inlet vent

This function allows an inlet vent after a hard vacuum test stop.

It allows the detector's inlet, and therefore the connected part or installation, to return to atmospheric pressure.

This function is secure: a confirmation message "Inlet vent? Please confirm." appears each time the operator requests an inlet vent.

From the "Settings" screen, press [Test] [Inlet vent].	
Inlet vent	⇒ Activate the function. Function activated if 'automatic' is set.
Delay	Setting required if 'automatic' is set. ⇒ Set the delay. Delay = time between the test stop and the automatic opening of the inlet vent valve. Allows a controlled valve to be closed before inlet vent.
Vent Timer	Setting optional if 'automatic' is set. ⇒ Activate the closing of the inlet vent valve. ⇒ Set the duration. Duration = time between the opening of the air inlet valve and its automatic closing. The automatic closing after a set duration is used to limit consumption of dry air or nitrogen, if purge is connected.



For quick access from the control panel, set a function key for [Inlet Vent] (see 7.7.2).

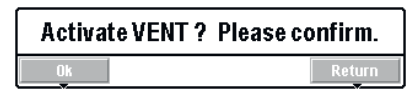



Fig. 24: "Activate vent" screen using a function key

If "Automatic" is selected, air enters automatically when  is pressed to stop the test. If 'Operator' is selected, press the corresponding function key to return the detector to atmospheric pressure.

Inlet vent manual activation from:

- the button **[Inlet vent]**
- the "Standard" screen (6) (see 6.1.4).



To lock the control for the inlet vent valve, delete the [Inlet vent] function key. The icon stays on the "Standard" screen as an indicator but manual activation by the operator will be deactivated.



NOTICE

Automatic inlet vent
Never programme 'automatic' inlet vent while the detector is connected to a high vacuum chamber or semi-conductor process chamber!
Select 'Operator' and/or delete the function key allocated to the automatic inlet vent. The inlet vent must be carried out using the menu, which can be password locked.



By connecting an inlet vent (or nitrogen) line to the inlet vent, the detector's tracer gas pollution is reduced.

7.4.6 Memo function

At the test stop, this function freezes the "Standard" screen with the leak rate measured during this test: the latest leak rate measured during the test displays and flashes.

From the "Settings" screen, press [Test] [Memo Function].

Active	⇒ Activate the function.
Display time	Setting required if the function is active. ⇒ Activate the display time delay. • On = the value of the measured leak rate flashes for the set duration. • Off = the value of the measured leak rate will flash until a new test begins. ⇒ Set the display duration.



For quick access from the control panel, set a function key for [Memo] (see 7.7.2).



Fig. 25: "Memo function" screen using a function key

7.4.7 Zero activation

This function is used to help the operator identify very small leak rate variations in the surrounding background or to dilate small measured leak rate fluctuations on the analogical display.

From the "Settings" screen, press [Test] [Zero Activation].

Activation	⇒ Activate the function (activated if 'automatic' is set).
Zero Exit	Setting required if 'operator' is set. ⇒ Set the type of keystroke for exiting the function (see below).
Trigger	Setting required if 'automatic' is set. ⇒ Set the function trigger factor.
Value	Setting required if 'automatic' is set. ⇒ Set the function trigger value.



To launch the function manually from the control panel, set a function key to [Zero] (see 7.7.2).

→ To activate the function manually, press the **[Zero]**.

- Press once: activate/deactivate zero by quickly pressing the **[Zero]** function key.
- Press > 3 s:
 - activation: quickly press the **[Zero]** function key. Each time the key is pressed quickly, a new zero is carried out.
 - deactivation: press > 3 s the **[Zero]** function key.



Using this function is recommended when the background of the tracer gas is stable and significant. This function is used to measure a leak rate that is lower :
 - 2 decades in hard vacuum test mode $5 \cdot 10^{-13}$ Pa·m³/s ($5 \cdot 10^{-12}$ mbar·l/s) maximum
 - 3 decades in sniffing mode ($5 \cdot 10^{-10}$ Pa·m³/s ($5 \cdot 10^{-9}$ mbar·l/s) maximum
than the detector's background when the detector is no longer in roughing.



To deactivate the Zéro [Zero] function key, set the activation to 'None'.

7.4.8 Regeneration

This function is used to "clean" the detector by automatically carrying out a series of short tests and inlet vents between each test. It allows to decrease the background further to a pollution in tracer gas.



NOTICE

Before launching this function, make sure that the leak detector is in an environment free of tracer gas pollution.

- Check that the detector is on Stand-by and that inlet vent is 'automatic'.
- From the "Settings" screen, press **[Test] [Regeneration]**.
- Block the detector's inlet port with a blanked-off flange.
- Press **[Start]**: regeneration will stop automatically after 1 hour.
- To stop regeneration before the automatic stop time, press **[Stop]** in the menu or . Start a test ("Zero activation" function not activated) to check that the detector is no longer polluted.

At the end of the regeneration, the configuration of the inlet vent is identical to what it was before the regeneration.



This function is recommended when the detector's background is high or when the part.



To launch the function from the control panel, set a function key to [Regeneration] (see 7.7.2).

7.4.9 Massive mode

This mode allows the detector to carry out a test (⁴He only) on a very gross leak in case the detector does not switch to Gross Leak mode and remains in roughing.

From the "Settings" screen, press [Test] [Massive Mode].

Active	⇒ Activate massive mode.
Sensitivity	⇒ Select the sensitivity <ul style="list-style-type: none"> • High = test on large volume (initial setting, recommended). Low = test on volume < 1 l (if necessary).

Function activated and pressure < 100 hPa, pressure stabilized during at least 10 s, a message notifies the operator that the detector has switched automatically to massive mode: the detector can then perform a qualitative leak test (leak information > 50 mbar·l/s (5 Pa·m³/s) only. The maximum use time is 55 minutes.



The massive mode cannot be used if an external gauge is selected (see 7.8.8).

7.5 Spectro Menu

- From the "Settings" screen, press **[Spectro]**.

Spectro		Return
Tracer Gas :	Helium	
Fil. Selected :	#1	
Filament :	On	
Fil. Status :	100%	
Calibrated Leak		

7.5.1 Tracer gas

The tracer gas is the gas searched for during a test. 3 gases are available: ⁴He, ³He and H₂.

From the "Settings" screen, press [Spectro].

Tracer gas ⇒ Select the tracer gas used.

The reject set point is stored for each configurable tracer gas.

Calibration

The leak detector should be calibrated with a calibrated leak of the same type as the tracer gas used.

Hydrogen test



DANGER

Explosion hazard.
For detecting leaks with 'hydrogen' tracer gas, the operator must use hydrogenated nitrogen (mix of 95 % N₂ and 5 % H₂).

The detector's background is higher level of Hydrogen than Helium.

Typical H₂ background, during a test, when the detector is equipped with a blanked-off flange on the inlet port:

- at switching on :
 - low level ± 1·10⁻⁶ Pa·m³/s (1·10⁻⁵ mbar·l/s)
- after 2 or 3 hours:
 - low level ± 1·10⁻⁷ Pa·m³/s (1·10⁻⁶ mbar·l/s)



For quick access from the control panel, set a function key for [Tracer Gas] (see 7.7.2).



Fig. 26: "Tracer Gas" screen using a function key

7.5.2 Filament parameters

Fil. Selected	Indicates the filament used for the measurement (2 filaments in the analyzer cell).
Filament	Indicates if the filament used is 'on' or 'off' when the detector is switched on.
Fil. status	Indicator of analyzer cell performance. Initial settings: between 90 % and 100 % Normal operation: between 10 % and 100 % Normal wear on some cell components will reduce this value over time but will not reduce the accuracy of the detector's measurements.

7.5.3 Calibrated leak

For more information about calibrated leaks, see *the Maintenance instructions*.

From the "Settings" screen, press [Spectro][Calibrated leak].

Tracer gas	⇒ Set the tracer gas for the calibrated leak used for calibration.
Type	⇒ Define the type of calibrated leak used for calibration. <ul style="list-style-type: none"> • internal = calibration using the leak detector's internal calibrated leak (⁴He leak only). • external = calibration using an external calibrated leak (⁴He, ³He or H₂ leaks).
Unit	⇒ Set the calibrated leak unit used for calibration. ⁽¹⁾
Leak Value	⇒ Set the calibrated leak value used for calibration. ⁽¹⁾
Calibration valve	⇒ Define the actual status of the calibration valve. Used to open/close the manual calibration valve, for example. Remember to close the valve again after use. Manual calibration is only for experts.
Loss per Year (%)	⇒ Set the loss rate per year for the calibrated leak used for calibration. ⁽¹⁾
Ref. T. (°C)	⇒ Set the reference temperature for the calibrated leak used for calibration. ⁽¹⁾

From the "Settings" screen, press [Spectro][Calibrated leak].

Coeff. T. (%/°C)	⇒ Set the temperature coefficient for the calibrated leak used for calibration. ⁽¹⁾
Year	⇒ Set the month and year of calibration for the calibrated leak used for calibration. ⁽¹⁾
Internal T. (°C) or External T. (°C)	'Internal' indicates the temperature at the detector's internal calibrated leak. 'External' indicates the temperature at the detector's external calibrated leak.

(1) Use the information indicated on the calibrated leak used for calibration or on its calibration certificate.

In case of calibrated leak replacement, these parameters must be updated. When the parameters are saved, all the data from all the calibrated leaks set (1 internal leak (^4He) and 3 external leaks (^4He , ^3He et H_2)) is memorised.

7.6 Maintenance Menu

→ From the "Settings" screen, press [Maintenance].

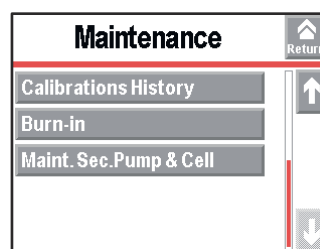
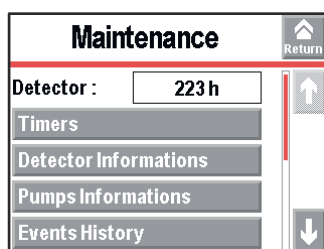

7.6.1 Detector

From the "Settings" screen, press [Maintenance].

Detector	Number of hours that the detector is used.
----------	--

7.6.2 Timers

From the "Settings" screen, press [Maintenance] [Timers].

Detector	Number of hours that the detector is switched on.
Filament 1	Number of hours that filament 1 is on. ⇒ Press [xxx h] [Counter reset] to reset the counter.
Filament 2	Number of hours that filament 2 is on. ⇒ Press [xxx h] [Counter reset] to reset the counter.
Calib. Leak	Indicates the month and year of calibration for the calibrated leak used for calibration.
Cycle Counter	Indicates the number of performed cycles since the last reset / the set cycle number. When the set value is reached, an information message is displayed.
Prim. Pump	Indicates the number of primary pump operating since the last reset / the set hour number. When the set value is reached, an information message is displayed.
Sec. Pump # 1	Indicates the number of secondary pump 1 operating since the last reset / the set hour number. When the set value is reached, an information message is displayed.



For quick access to the counters from the control panel, set a function key for [Maintenance] (see 7.7.2).

→ To set the set point and reset the cycle counter

From the "Settings" screen, press [Maintenance] [Timers] [xxxx Cy/xxxx Cy].

Cycles	Indicates as a % the number of cycles made in relation to the interval set.
Counter	Indicates the number of cycles made since the latest reset of the counter.
Interval	⇒ Set the value for the counter. When the set value is reached, an information message is displayed.
Reset Counter	⇒ Press [Counter reset] to reset the counter.

➔ To set the set point and reset the operating hours counter for each pump's ,

From the "Settings" screen, press [Maintenance] [Timers] [xxxx h/xxxx h] for each pump.

Pump XXX	Indicates as a % the number of operating hours for the pump XXX in relation to the interval set.
Counter	Indicates the number of operating hours for the pump since the latest reset of the counter.
Time Interval	⇒ Set the value for the counter. When the set value is reached, an information message is displayed.
Reset Counter	⇒ Press [Counter reset] to reset the counter.

Primary pump: RVP 1015
Secondary pump 1: Splitflow 50

7.6.3 Detector Information

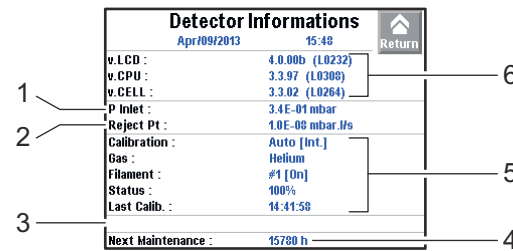

Fig. 27: Detector Information

1	Inlet pressure
2	Reject set point for the test method in progress
3	List of activated functions
4	Primary or secondary pump maintenance
5	Calibration information
6	Detector firmware information



For quick access from the control panel, set a function key for [Infor.] (see 7.7.2).

7.6.4 Pump Information

Primary Pump #1

No pump information for the Wet and Integrable Models: the message "No parameter available" is displayed.

Secondary Pump #1

From the "Settings" screen, press [Maintenance] [Pump Information] [Sec. Pump #1].

Status	Control of the pump by the detector
Rotation	Pump status: Synchro/Down/Fail/Running/Ram up
Speed (rpm)	Pump running speed : <ul style="list-style-type: none"> ● Hard Vacuum test = 90000 ● Sniffing test = 60000

➔ For more information about secondary pump #1, press **[TMP Information]**.

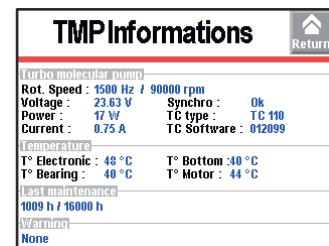

7.6.5 Event history

Event history records the last 30 events. Beyond 30, the oldest recorded event will be replaced by the most recent, and so on.

→ From the "Settings" screen, press **[Maintenance] [Event History]**.

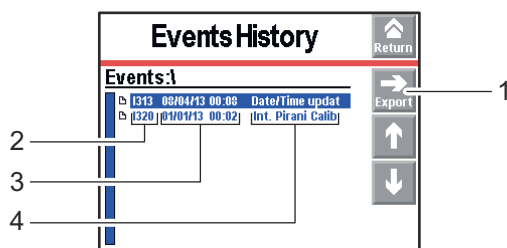

1	Exporting the history in .csv format to the SD card
2	RS-232 code for the event
3	Date - Time of the event
4	Description of the event

Event = Error (Exxx) or Warning (Wxxx) or Event (Ixxx)

List of errors and warnings: see **List of warnings/faults** in *Maintenance instructions*.

List of events:

RS-232 Code	Event	Description
I300	Inlet vent	Inlet vent
I301	Stp on pollution	Test stops automatically if leak rate pollution > Pollution
I302	RVP ctr reset	Primary pump hour counter reset.
I303	TMP1 ctr reset	Secondary pump 1 hour counter reset
I305	TMP3 ctr reset	Secondary pump 3 hour counter reset
I306	Fil 1 ctr reset	Filament 1 hour counter reset
I307	Fil 2 ctr reset	Filament 2 hour counter reset
I308	Cycle ctr reset	Cycle counter reset
I310	Autocal restart	Automatic start of a new autocalibration
I313	Date/Time up - Date	Date or time modification
I318	Full param reset	Detector parameters completely reset
I319	Fil change	Filament change (manually or automatically from Maintenance menu
I320	Int. Pirani Calib.	Automatic internal Pirani gauge calibration
I321	Storage delay	Detector switched off for 15 days (minimum)

7.6.6 Calibration history

The calibration history records the last 20 calibrations made. Beyond 20, the oldest recorded calibration will be replaced by the most recent and so on.

→ From the "Settings" screen, press **[Maintenance] [Calibration History]**.

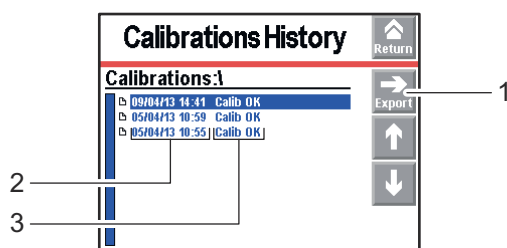

1	Exporting the history in .csv format to the SD card
2	Date - Time of the calibration
3	Calibration result

7.6.7 Burn-in

This function is used to prepare the detector, leaving it in optimal working condition by automatically carrying out a series of short tests and inlet vents between each test.



NOTICE

Before launching this function, make sure that the leak detector is in an environment free of tracer gas pollution.

- Check that the detector is on Stand-by and that inlet vent is 'automatic'.
- From the "Settings" screen, press **[Maintenance] [Burn-in]**.
- Block the detector's inlet port with a blanked-off flange.
- Press **[Start without calib.]** or **[Start with calib.]**: burn-in does not stop automatically.
 - **[Start without calib.]** = series of tests and inlet vents
 - **[Start with calib.]** = series of tests, inlet vents and calibrations (not available for sniffing test)
- To stop burn-in, press **[Stop]** on the menu or  .

7.6.8 Maintenance for the analyzer cell and the secondary pump

To carry out maintenance on the secondary pump or the analyzer cell, the vacuum part of the detector must be at atmospheric pressure. This function is used to shut down the secondary pump and to perform an inlet vent so that the secondary pump and the analyzer cell are at atmospheric pressure.

- From the "Settings" screen, press **[Maintenance] [Maint.Sec. Pump & Cell]**.
- Press **[Stop & Vent]** to start the function.
 - The secondary pump slows to a speed that allows inlet vent.
 - A message notifies the operator when the leak detector can be shut down.
- Optional: to carry out an additional inlet vent before shutting down the detector, press **[Stop&Vent]**.
- If the operator does not want to shut down the detector, press **[Restart detector]**: the detector start-up screen is displayed.
- Shut down the detector, wait until the control panel turns off completely and unplug the electric power cable before working on the detector.

7.7 Configuration Menu

- From the "Settings" screen, press **[Config.]**.

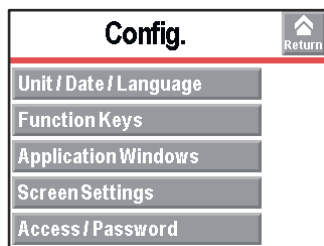

7.7.1 Time - Date - Unit - Language

The update of these parameters is automatically requested when the operator switches the detector on for the first time: after this, the operator can modify them at any time.

From the "Settings" screen, press [Config.] [Unit/Date/Language].

Unit	⇒ Set the unit to be used. The set points/values set are not automatically converted to the new unit if the unit changes: they must be updated by the operator.
Date	⇒ Set the current date.
Time	⇒ Set the time. The time is not automatically updated when switching from summer time to winter time and vice versa: it must be updated by the operator.
Language	⇒ Set the language.

7.7.2 Function keys

The function keys are used to activate/stop a function or to adjust set points.

Per initial settings, 8 function keys are allocated and distributed over 2 levels: they can be reallocated by the operator.

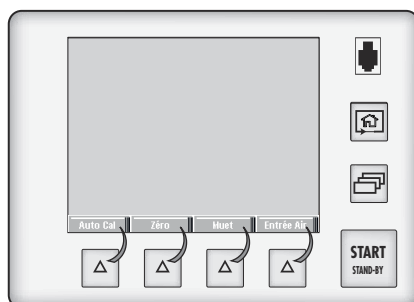

Fig. 28: Function keys

Allocating function keys

→ From the "Settings" screen, press **[Config.] [Function Keys]**.



Thanks to the function keys, it is possible to give the operator access to a limited number of functions and to use a password to lock unauthorised functions on the "Settings" menu. They are sufficient to manage the detector.

→ To allow the operator to use only the **[Start/Stand-by]** key, do not allocate a function to the function keys and lock the "Settings" menu.

→ Up to 4 additional function keys can be added, for a maximum of 12. In this case, a 3rd level is made available to the operator.

Each function key can be allocated to a function chosen by the operator: see the example below.

Example: Allocate the 'Correction' function (1) to the **[Mode]** function key (2).

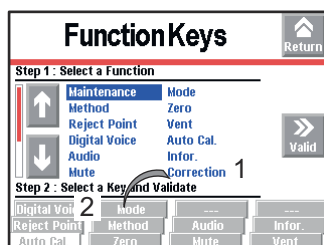

Fig. 29: Allocation objective

→ Select the 'Correction' function (1) using the and .

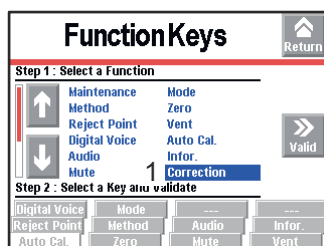

Fig. 30: Selecting the function

→ Select the **[Mode]** function key (2) by pressing repeatedly (key selected if background is white).

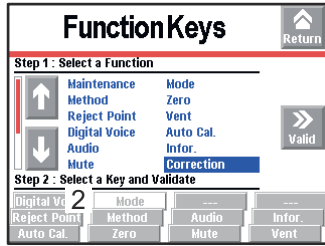

Fig. 31: Selecting the function key

→ Validate the settings (3): the function key (2) is now allocated to the [Correction] function.

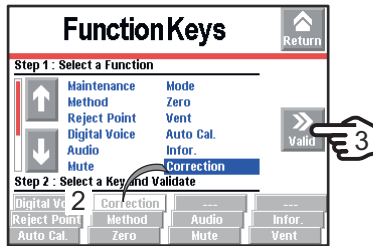



Fig. 32: Result of the allocation

7.7.3 Application screens



→ From the "Settings" screen, press [Config.][Application Windows].

By pressing repeatedly on the key , the various screens available appear (see 6.1.3).

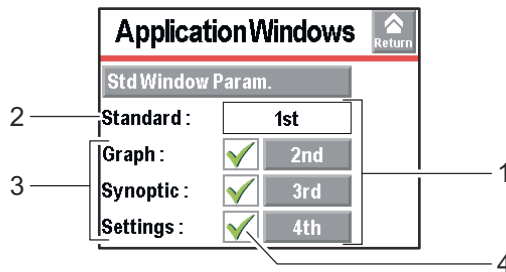
The operator can hide one or more screen or switch the order in which they appear. The "Standard" application screen is always available in 1st position.



1	Order of the displayed screens with the key 	
2	"Standard" application screen always displayed	
3	Available screens	
4	Displaying/hiding the application screen	

The screen order can be modified: press the order number (example: [3rd]) and use the  and  keys to choose the new order number then confirm.

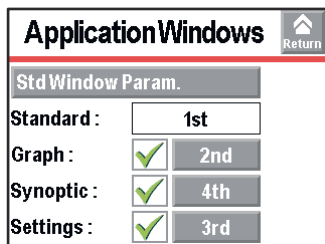



Fig. 33: The "Synoptic" screen order has switched from 3 to 4

When a screen is no longer selected  or if its order has been changed, the general order is automatically updated.

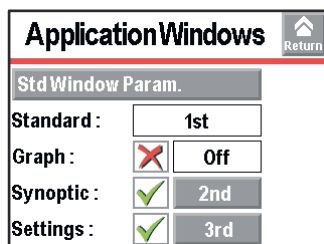

Fig. 34: The "Graph" screen is no longer available

When a screen is selected again, it automatically moves to last place.

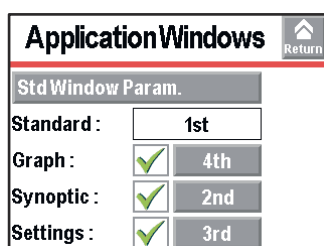

Fig. 35: The "Graph" screen is available again, and in last place.

Setting the "Standard" screen

From the "Settings" screen, press [Config.] [Application Windows] [Std Window Parameters].

Std-By Value	⇒ Display/Hide the leak rate display in Stand-by mode.
Inlet Pressure	⇒ Display/Hide the inlet pressure display.
Extra Pressure	⇒ Display/Hide the pressure display of for the cell or an external gauge. The external gauge (at the customer's expense) is a gauge installed on the customer's application, connected to the 37 pin I/O board.
Lower Display Limit	⇒ Set the minimum value displayed for leak rate. Leak rate not displayed if the value is less than the 'Lower Display Limit' configured value.

From the "Settings" screen, press [Config.] [Application Windows] [Std. Window Parameters] [Leak Rate Bargraph].

Zoom on set point	⇒ Activate zoom to set point. Zoom to set point is used to display on the bargraph the reject set point centred on 2 decades.
Low Decade	⇒ Set the low decade for the bargraph display.
High Decade	⇒ Set the high decade for the bargraph display.

7.7.4 Screen Settings

From the "Settings" screen, press [Config.] [Screen Settings].

Brightness	⇒ Set the brightness.
Contrast	⇒ Set the contrast.
Panel off	⇒ Activate the sleep mode screen. The screen is in sleep mode when the back light goes off (black screen). The device appears to be off, but this is not the case! Simply touching the screen reactivates the display.
Paging Func.	⇒ Activate the Paging function. When a RC 500 WL remote control (accessory) is used, the 'Paging' function makes it possible to easily find the remote if it is located within its field of use with the detector. When the function is activated, the remote emits a sound signal so it can be located. To stop the sound signal, deactivate the Paging function.

→ Press [Reset Panel Param.] to reset the control panel parameters.



7.7.5 Access - Password

→ From the "Settings" screen, press [Config.] [Access/Password].

→ Enter the password ('5555' by default) and validate.

Menu access

The operator can lock access to one or more menus on the "Settings" screen. To access a locked menu, the operator will be asked to provide the password.

- Lock a menu by pressing  .
- Unlock a menu by pressing  .

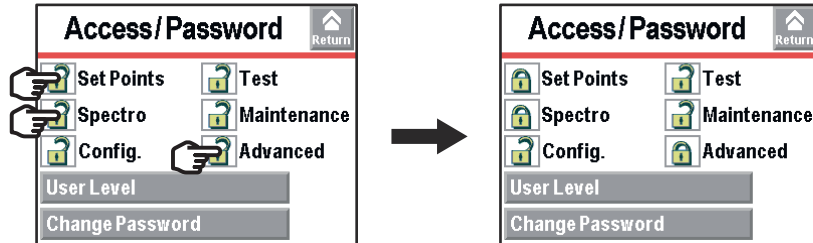

Fig. 36: Example: Locking the Set Points, Spectro and Advanced menus

On the "Settings" screen, the locked menus are indicated by  .

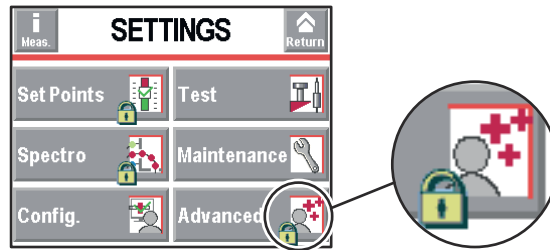

Fig. 37: Locked menus

Change password

- From the "Settings" screen, press **[Config.] [Access/Password]**.
- Enter the password ('5555' by default) and validate.
- Press **[Change Password]**.
- Enter the new password and validate.



The password is saved in the control panel. If the password is forgotten, it can be found using the RS-232: see the RS-232 operating instructions.



User level

→ From the "Settings" screen, press **[Config.] [Access/Password] [User level]**.

3 user levels can be used to restrict the display and operator access to settings and functions:

- restricted access,
- medium access,
- full access.

Limits with Restricted access

- Key  invalid: no settings can be made without password.
- Pictogram  invalid.
- Function keys hidden.
- Inlet pressure and cell pressure hidden.
- Key  invalid: launch of a test via a communication interface only.
- Measured leak rate and reject set point displayed only in test.

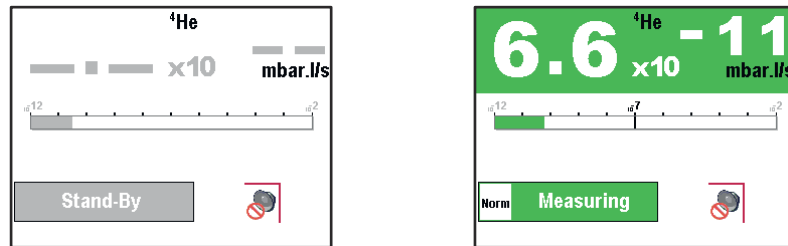



Fig. 38: Displays with Restricted access





With Medium or Restricted access, the operator can temporarily access the 6 menus on the "Settings" screen to set parameters.

- Press and hold the key  until the "Settings" screen is displayed with all the locked menus.
- Press the desired menu.
- Enter the current password ('5555' by default) and validate.
- Carry out the desired parameter settings.

Limits with Medium access

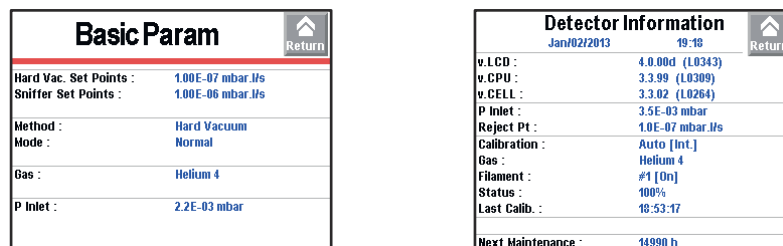
- Key  invalid: no settings can be made without password.
- 2 function keys available: **[Basic Param.]** and **[Info]**.



- Function keys hidden.
- Inlet pressure and cell pressure hidden.
- Key  valid.
- Measured leak rate and reject set point displayed only in test.

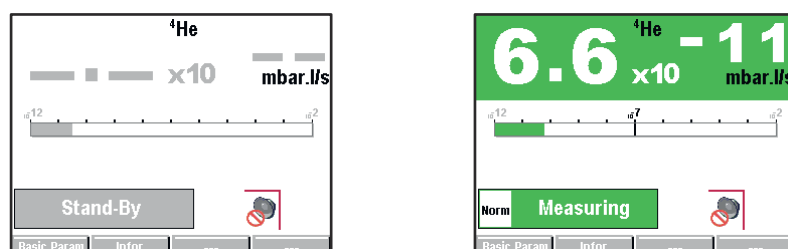



Fig. 39: Displays with Medium access



With Medium or Restricted access, the operator can temporarily access the 6 menus on the "Settings" screen to set parameters.

- Press and hold the key  until the "Settings" screen is displayed with all the locked menus.
- Press the desired menu.
- Enter the current password ('5555' by default) and validate.
- Carry out the desired parameter settings.

Limits with Full access

- No limit.

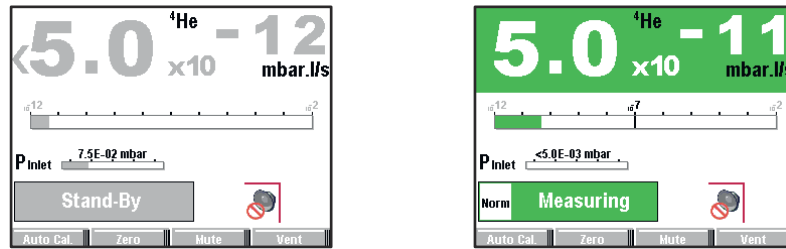



Fig. 40:Displays with Full access

Operator with Restricted or Medium access changing the access level.

- Press  until the "Settings" screen is displayed with all the locked menus.
- Press **[Config.]**.
- Enter the current password ('5555' by default) and validate.
- Press **[Access/Password]**.
- Enter the current password ('5555' by default) and validate.
- Press **[User Level]**.
- Change the access level: see below the limits for each level.

Operator with Full access changing the access level.

- From the "Settings" screen, press **[Config.] [Access/Password]**.
- Enter the current password ('5555' by default) and validate.
- Press **[User Level]**.
- Change the access level: see below the limits for each level.

7.8 Advanced Menu

The Advanced menu is reserved for leak detection experts and/or for setting a particular product.

- From the "Settings" screen, press **[Advanced]**.

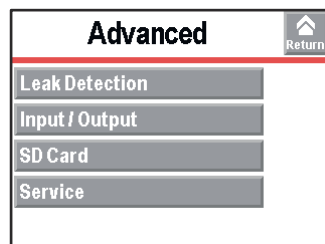

7.8.1 Leak Detection Menu

- From the "Settings" screen, press **[Advanced] [Leak Detection]**.

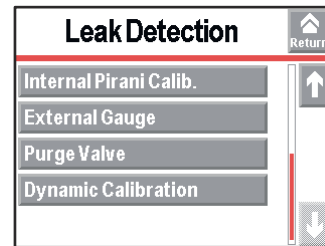
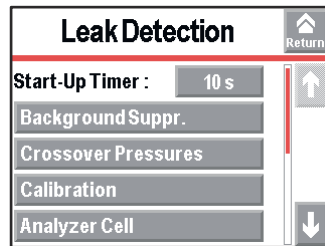

7.8.2 Leak Detection: Start-up timer

The start-up timer prevents the leak detector from being used for a pre-determined duration after it has been switched on. This means measurements cannot be made until the leak detector is thermally stabilized, or while traces of tracer gas remain in the detector.

From the "Settings" screen, press [Advanced] [Leak Detection].

Start-up timer	⇒ Set the start-up timer.
----------------	---------------------------

7.8.3 Leak detection: Background suppression

This function is used to suppress the detector's background.

From the "Settings" screen, press [Advanced] [Leak Detection] [Background Suppr.].

Activation	⇒ Activate the function ('on' if activated).
------------	--

Note: after calibration, with background suppression function activated, the leak detector's background will be lower than $5 \cdot 10^{-13} \text{ Pa} \cdot \text{m}^3/\text{s}$ ($5 \cdot 10^{-12} \text{ mbar} \cdot \text{l/s}$).



This function is recommended for testing very small leaks, which improves measurement and reading.
This function can be used to measure a leak rate 2 decades lower than the detector's background, when the detector is no longer in roughing.

7.8.4 Leak Detection: Crossover Pressures

In a hard vacuum test, used to define the crossover pressures in the different test modes.

From the "Settings" screen, press [Advanced] [Leak Detection] [Crossover pressures].

Gross Leak	⇒ Set the cross over from Roughing to Gross Leak mode.
------------	--

Normal	⇒ Set the cross over from Gross Leak mode to Normal mode.
--------	---

7.8.5 Leak Detection: Calibration



NOTICE

Detector calibration

20 minutes after the switched on, the detector suggests that the operator carry out an auto-calibration (if calibration parameter = 'operator'). For the correct use of the detector, **this auto-calibration must be performed**. In all situations, a calibration must be performed:

- at least once a day
- to optimise the measurement reliability for high sensitivity tests
- if it is uncertain whether the detector is working properly
- during intense and continuous operation: start an internal calibration at the beginning of each work session (e.g. work in teams, every 8 hours).

Calibration makes it possible to verify that the detector is properly adjusted to detect the selected tracer gas and display the correct leak rate value.

From the "Settings" screen, press [Advanced] [Leak Detection] [Calibration].	
Calibration	⇒ Select the type of calibration. See details below.
Calib. Checking	⇒ Activate the calibration checking and set the frequency. See details below.

If there is no internal calibrated leak, calibration can be performed with an external calibrated leak. By default, autocalibration is set to 'On' and the internal leak is selected so that the detector can be calibrated quickly.

Calibration = 'operator'

Calibration started by the operator.

➔ Press the [AUTOCAL].

If calibration does not start within 20 minutes after the leak detector is switched on, message is displayed.

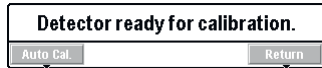

Fig. 41: Leak detector ready for calibration

Calibration = 'start-up'

Calibration starts automatically when the leak detector is switched on.

Calibration = 'manual'

Calibration starts manually.

Operation reserved for service centres and experts only.

The leak detector can also be calibrated using an external leak (see *Calibration in the Maintenance instructions*).

"Calibration control" setting

Calibration control saves the operator time because the calibration control is quicker than the full calibration.

If calibration = 'operator' or 'start-up', the calibration control function performs a control of the calibration according to the parameters set.

The calibration control is deactivated if calibration = 'manual'.

The calibration control is performed with the leak detector's internal calibrated leak (leak type parameter = 'internal').

The leak detector compares the measured leak rate of the internal calibrated leak with the set leak rate of the internal calibrated leak:

- If the ratio is within the limits allowed, the leak detector is properly calibrated.
- If the ratio is outside those limits, a message appears suggesting that a full calibration of the leak detector be started.

Checking	⇒ Select the type of calibration (activated if 'automatic' has been set).
Frequency	⇒ Set the set points (cycles and times) for triggering the calibration control. The first set point reached will trigger the control.



To launch the function from the control panel, set a function key to [Check Cal].



At any time, the operator can start a leak detector calibration control: detector in Stand-by mode, press the [AUTOCAL] function key twice within 5 seconds.

7.8.6 Leak detection: Analyzer cell

From the "Settings" screen, press [Advanced] [Leak Detection] [Analyzer Cell].	
Fil. Selected	Indicates the filament used for the measurement (2 filaments in the analyzer cell).
Filament	Indicates if the filament used is 'on' or 'off' when the detector is switched on.
- Triode pressure - Elec. Zero - Target value - Acc. voltage (V) - Emission (mA) - Coeff. Sens.	Parameters for manual calibration. This type of calibration is reserved for service centres and leak detection experts only.
Calib. valve	⇒ Define the actual status of the calibration valve. Used to open/close manually the calibration valve, for example. Remember to close the valve again after use. Manual calibration is only for experts.

From the "Settings" screen, press [Advanced] [Leak Detection] [Analyzer Cell].

Internal T (°C)	'Internal' indicates the temperature at the detector's internal calibrated leak.
or	'External' indicates the temperature at the detector's external calibrated leak.
External T (°C)	



Do not switch off the filament except for carrying out manual calibration. It is not necessary to switch the filament off in Stand-by mode to save it.

- The leak detector switches automatically from one filament to the other if the selected filament currently being used becomes defective.
- When switched on, the leak detector uses the filament that was selected when it was shut down.

7.8.7 Leak Detection: Internal Pirani gauge calibration

Procedure → From the "Settings" screen, press **[Advanced] [Leak Detection] [Internal Pirani Calib.]**.

→ Block the detector's inlet with a blanked-off flange.

→ Make sure:

- that the leak detector is in a hard vacuum test, in the most sensitive test mode.
- that the end of the cycle is manual (= 'operator').

The calibration takes place in 2 stages: setting the limit pressure and setting the atmospheric pressure.

Setting the limit pressure

→ Start a test: press .

→ The "Pressure" value decreases: wait for this value to stabilise (around 5 minutes).

→ Make sure that the internal pressure is significantly lower than $1 \cdot 10^{-3}$ hPa.

→ Press the **[>HV]**.

Setting the atmospheric pressure

→ Stop the test: press the .

→ Create an inlet vent: press **[Inlet vent]**.

→ Make sure that the detector is at atmospheric pressure.

→ The "Pressure" value increases: wait for this value to stabilise (around 5 minutes) and press the **[>Atm]**.

7.8.8 Leak Detection: External gauge

Allows the leak detector to be managed by an external gauge.

Prerequisites

- Detector equipped with the 37 pin I/O board (option or accessory (see 10)).

→ Deactivate the Massive mode to use an external gauge Massive Mode (see 7.4.9).

→ Configure the pressure source of the pump inlet (= 'external').

Possible gauges

		Type of gauge detected by the detector	Gauge model
Linear gauges	Capacitives	Linear	CMRxxx
	Piezo	Linear	APRxxx
Logarithmic gauges	Pirani	TPR/PCR	TPRxxx
	Capacitives Pirani	TPR/PCR	PCRxxx

- The gauge and the cable are the client's responsibility

Settings

From the "Settings" screen, press [Advanced] [Leak Detection] [External Gauge].

Gauge	⇒ Select the external gauge model.
Ext. Pressure (mbar)	Indicates the pressure measured by the external gauge.
Inlet Press. source	⇒ Set the inlet pressure displayed on the "Standard" screen: 'internal' (leak detector's internal gauge) or 'external' (external gauge on the customer's installation)
Full scale (mbar)	Only for a linear gauge
	⇒ Set the operating range for the gauge: value indicated on the gauge.

7.8.9 Input/Output menu

→ From the "Settings" screen, press **[Advanced]** **[Input/Output]**.

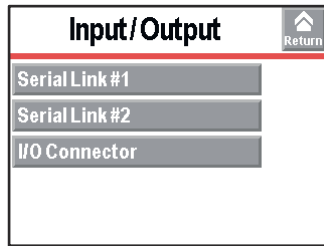

7.8.10 Input/Output: Serial Link 1 and Serial Link 2

From the "Settings" screen, press **[Advanced]** **[Input/Output]**, then **[Serial Link 1]** or **[Serial Link 2]**.

Type	⇒ Set the type of serial link: see table below.
Parameters	⇒ Set the serial link mode: see detail below.

The operator must allocate the 2 serial links (1 and 2) according to their use.

Use	Possible allocation		Type to select
	Serial Link 1	Serial Link 2	
RS-232	yes	no	Serial
USB	yes	yes	USB
Wireless remote control ⁽¹⁾	yes	no	Serial

⁽¹⁾ Accessory

Parameters → From the "Settings" screen, press **[Advanced]** **[Input/Output]** **[Serial Link 1]** or **[Serial Link 2]** **[Parameters]**.

Mode	Description	Use	
		RS-232	USB
Basic	Continuous acquisition of data sent to the hyperterminal according to a defined time duration. At any time, a command can be sent to the leak detector. Recommended mode during leak detector test procedure setting operations.	x	x
Spreadsheet	Variant on the Basic mode. Continuous data acquisition, formatted in a spreadsheet such as Excel Microsoft® Office or other similar software. Recommended mode for drawing graphs.	x	x
Advanced	Full control of the detector by a supervisor. The detector sends information at the supervisor's request. 5 V power supply available. Recommended mode for automatic systems.	x	x
Export Data	Export, via a PC, of "tickets" issued by the detector after: <ul style="list-style-type: none"> • Calibration with an internal/external calibrated leak, • Calibration control with an internal leak, • A test. Serial links 1 and 2 must not be in "Export Data" mode at the same time.	x	x
RC 500 WL	Use of a wireless remote control. ⁽¹⁾	x	-
PV Protocol	Protocol for compatibility with the HLTxxx detector protocol. List of orders for the protocol compatible with TAPIR HL 2216 A. (<i>See the RS-232 operating instructions</i>).	x	x
Ext. Module	Full control of the detector by a supervisor. The detector sends information at the supervisor's request. 24 V power supply available. A 24 V power supply is required for using an external module.	x	-

⁽¹⁾ See Wireless remote control operating instructions for more details.

7.8.11 Input/Output: I/O connector

→ From the "Settings" screen, press **[Advanced] [Input/Output] [I/O Connector]**.

The detector is equipped with a 37 pin I/O interface (see **37 pin I/O board Operating instructions**).

7.8.12 SD Card menu

From the "Settings" screen, press [Advanced] [SD card].

Load Detector Param.	⇒ Load the saved parameters onto the SD card.
Save Detector Param.	⇒ Save the leak detector parameters to the SD card.
View * BMP	⇒ View the saved ".bmp" files.



Creating a library of the configurations for each application is recommended if the detector is used for more than one application. Any SD card on the market can be used except cards with High Capacity technology, regardless of the memory size. Before use, make sure that the SD card is not locked (message "SD card not detected" displayed).

7.8.13 Service

Access to the Service menu is password protected. Reserved for the Service Centres.

8 Maintenance / replacement



NOTICE

Disclaimer of liability

Busch accepts no liability for personal injury or material damage, losses or operating malfunctions due to improperly performed maintenance. The liability and warranty entitlement expires.

8.1 Maintenance intervals and responsibilities

The detector maintenance operations are described in the ***Maintenance instructions*** for the detector.

The manual specifies:

- maintenance intervals
- maintenance instructions
- shutting the product down
- tools and spare parts.

Please contact your local Busch company for maintenance support.

9 Service

Busch offers first-class customer service!

- On-Site maintenance for many products
- Overhaul/repair at the nearby Service Location

Detailed information, addresses and forms at: www.buschvacuum.com/services.

Overhaul and repair at the Busch Service Center

The following general recommendations will ensure a fast, smooth servicing process:

- Fill out the "Service Request/Product Return" form and send it to your local Busch Service contact.
- Include the confirmation on the service request from Busch with your shipment.
- Fill out the declaration of contamination and include it in the shipment (mandatory!). The Declaration of contamination is valid for any product/device including a part exposed to vacuum.
- Dismantle all accessories and keep them.
- Close all the flange opening ports by using the original protective covers or metallic airtight blank flanges for contaminated devices.
- If possible, send the pump or unit in its original packaging.

Sending contaminated pumps or devices

No devices will be accepted if they are contaminated with micro-biological, explosive, or radioactive substances. "Hazardous substances" are substances and compounds in accordance with the hazardous goods regulations (current version).

- Neutralize the pump by flushing it with nitrogen or dry air.
- Close all openings airtight.
- Seal the pump or device in suitable protective film.
- Return the pump/device only in a suitable and sturdy transport container and send it in while following applicable transport conditions.

Pump or device returned without declaration of contamination form fully completed and/or not secured in suitable packaging will be decontaminated and/or returned at the shipper's expense.

Exchange or repair

The factory operating parameters are always pre-set with exchange or repaired devices. If you use specific parameters for your application, you have to set these again.

Service orders

All service orders are carried out exclusively according to our general terms and conditions for the repair and maintenance, available on our website.

10 Accessories

Description	Order number
Sniffer probe, 5 m hose, 9 cm long tip	0659230817
Helium spray gun	0995230816
Transport trolley	0943232412
Inlet filter 5 µm	0945232413
Inlet filter 40 µm	0945232414

11 Technical data and dimensions

11.1 General

Databases of the leak detectors' technical characteristics:

- Technical characteristics according to:
 - AVS 2.3: Procedure for calibrating gas analyzers of the mass spectrometer type.
 - EN 1518: Non-destructive testing. Leak testing. Characterization of mass spectrometer leak detectors.
 - ISO 3530: Methods of calibrating leak-detectors of the mass-spectrometer-type used in the field of vacuum technology.
- Zero function or background suppression activated, in standard conditions (20 °C, 5 ppm ⁴He ambient, degassed detector).
- Acoustic pressure level: distance in relation to the detector 1 m.

11.2 Technical data

Parameter	TAPIR HL 2216 A
Flange (in)	DN 25 ISO-KF
Pumping speed for He	2.5 l/s
Backing pump capacity	15 m ³ /h
Start-up time (20°C) without calibration	~ 3 min
Noise level	54 dB(A)
Protection category	IP 20
Power consumption max.	850 W
Operating temperature (hard vacuum test)	0 – 45 °C
Operating temperature (sniffing test)	0 – 35 °C
Maximum inlet test pressure	25 hPa
Weight	56 kg
Detectable gases	⁴ He, ³ He, H ₂
Test method	Vacuum & sniffing leak detection
Minimum detectable leak rate for helium (sniffing leak detection)	5 · 10 ⁻¹⁰ Pa m ³ /s
Minimum detectable leak rate for helium (vacuum leak detection)	5 · 10 ⁻¹³ Pa m ³ /s
Supply ³⁾	100-130 V, 50/60 Hz 200-240 V, 50/60 Hz

¹⁾ If primary pump limit vacuum < 5 · 10⁻² hPa. If not, +0 °C to +40 °C.

²⁾ Between 25 mbar and 5 mbar, qualitative measurement only.

³⁾ In accordance with EC regulations, the pumps can withstand a voltage variation of ±10%.

Environmental conditions	
Storage temperature	-20 °C to +55 °C
Maximum humidity of air	85 %, without condensing
Maximum magnetic field	3 mT
Overvoltage protection	II
Pollution level	Level 2
Altitude	Up to 2000 m
Use	Indoor use

11.3 Units of measurement

Conversion table: pressure units

	mbar	bar	Pa	hPa	kPa	Torr mm Hg
mbar	1	1 · 10 ⁻³	100	1	0.1	0.75
bar	1000	1	1 · 10 ⁵	1000	100	750
Pa	0.01	1 · 10 ⁻⁵	1	0.01	1 · 10 ⁻³	7.5 · 10 ⁻³
hPa	1	1 · 10 ⁻³	100	1	0.1	0.75
kPa	10	0.01	1000	10	1	7.5

	mbar	bar	Pa	hPa	kPa	Torr mm Hg
Torr mm Hg	1.33	$1.33 \cdot 10^{-3}$	133.32	1.33	0.133	1

$1 \text{ Pa} = 1 \text{ N/m}^2$

Conversion table: gas throughput units

	mbar·l/s	Pa·m ³ /s	sccm	Torr·l/s	atm·cm ³ /s
mbar·l/s	1	0.1	59.2	0.75	0.987
Pa·m ³ /s	10	1	592	7.5	9.87
sccm	$1.69 \cdot 10^{-2}$	$1.69 \cdot 10^{-3}$	1	$1.27 \cdot 10^{-2}$	$1.67 \cdot 10^{-2}$
Torr·l/s	1.33	0.133	78.9	1	1.32
atm·cm ³ /s	1.01	0.101	59.8	0.76	1

11.4 Dimensions

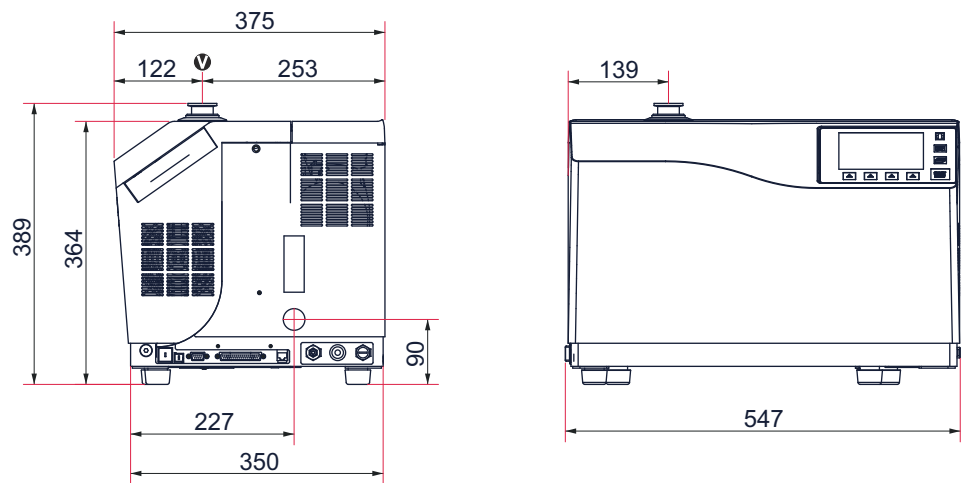

EU-Declaration of Conformity

This Declaration of Conformity and the CE-mark affixed to the nameplate are valid for the machine within the Busch scope of delivery. This declaration of Conformity is issued under the sole responsibility of the manufacturer. When this machine is integrated into a superordinate machinery the manufacturer of the superordinate machinery (this can be the operating company, too) must conduct the conformity assessment process for the superordinate machine or plant, issue the Declaration of Conformity for it and affix the CE-mark.

The manufacturer:

**Ateliers Busch S.A.
Zone Industrielle
CH-2906 Chevenez**

declares that the machine(s) **TAPIR HL 2216 A**

has (have) been manufactured in accordance with the European Directives:

- "Low Voltage" 2014/35/EU
- "Machinery" 2006/42/EC (Annex II, No. 1 A)
- "Electromagnetic Compatibility" 2014/30/EU
- "Restriction of Hazardous Substances" 2011/65/EU
- "Waste of Electrical and Electronical Equipments" 2012/19/EU
This directive does not imply CE marking.

and following the standards:

Standard	Title of the standard
EN 61010-1:2011	Safety requirements for electrical equipment for measurement, control, and laboratory use - Part 1 : general requirements
EN 60204-1:2006	Safety of machinery - Electrical equipment of machines - Part 1: General requirements
EN 61326-1: 2013	Electrical equipment for measurement, control and laboratory use. EMC requirements. General requirements
EN 50581: 2013	Technical documentation for the assessment of electrical and electronic products with respect to the restriction of hazardous substances

Person authorised to compile the technical file:

Gerd Rohweder
Busch Dienste GmbH
Schauinslandstr. 1
DE-79689 Maulburg

Chevenez, 18.06.2020



Christian Hoffmann, General director

Busch Vacuum Solutions

We shape vacuum for you.

Argentina

info@busch.com.ar

Australia

sales@busch.com.au

Austria

busch@busch.at

Bangladesh

sales@busch.com.bd

Belgium

info@busch.be

Brazil

vendas@buschdobrasil.com.br

Canada

info@busch.ca

Chile

info@busch.cl

China

info@busch-china.com

Colombia

info@buschvacuum.co

Czech Republic

info@buschvacuum.cz

Denmark

info@busch.dk

Finland

info@busch.fi

France

busch@busch.fr

Germany

info@busch.de

Hungary

busch@buschvacuum.hu

India

sales@buschindia.com

Ireland

sales@busch.ie

Israel

service_sales@busch.co.il

Italy

info@busch.it

Japan

info@busch.co.jp

Korea

busch@busch.co.kr

Malaysia

busch@busch.com.my

Mexico

info@busch.com.mx

Netherlands

info@busch.nl

New Zealand

sales@busch.co.nz

Norway

post@busch.no

Peru

info@busch.com.pe

Poland

busch@busch.com.pl

Portugal

busch@busch.pt

Romania

office@buschromania.ro

Russia

info@busch.ru

Singapore

sales@busch.com.sg

South Africa

info@busch.co.za

Spain

contacto@buschiberica.es

Sweden

info@busch.se

Switzerland

info@buschag.ch

Taiwan

service@busch.com.tw

Thailand

info@busch.co.th

Turkey

vakutek@ttmail.com

United Arab Emirates

sales@busch.ae

United Kingdom

sales@busch.co.uk

USA

info@buschusa.com