



INFICON

Modul1000

Helium Leak Detector

IDEAL FOR TESTING PART VOLUMES
FROM 0.01 UP TO 1000 LITERS

OPTIMIZE YOUR PRODUCTION HELIUM LEAK TESTING WITH A RELIABLE, INTELLIGENT AND REPEATABLE PLATFORM

The Modul1000 is a plug-and-play helium leak detector for universal integration into industrial leak testing systems (vacuum or sniffer mode). With flexible vacuum architecture, the Modul1000 provides the adaptability to accommodate changes in production specifications.

RELIABLE FOR MAXIMUM UPTIME

The Modul1000 provides maximum measurement stability and ambient conditions isolation for repeatable measurement over long periods of time in changing conditions. The ion source filament is designed for long life and is supported with a 3-year replacement guarantee to minimize costly unscheduled downtime and maintenance expenses.

INTELLIGENT DESIGN IMPROVES MEASUREMENT CERTAINTY

The software algorithm I-CAL™ provides accurate measurements at unsurpassed speed in all measurement ranges. This enables the Modul1000 to recognize and communicate the true leak rate faster.

To facilitate unit exchange, user setups are stored in the removable I-Stick for easy, fast parameter transfer.

The Modul1000 offers flexible inputs and status outputs for PLC control. Additionally, control and data acquisition is available via the RS232 communication port. The optional display unit supplies easy operation through an intuitive menu structure and software menus.

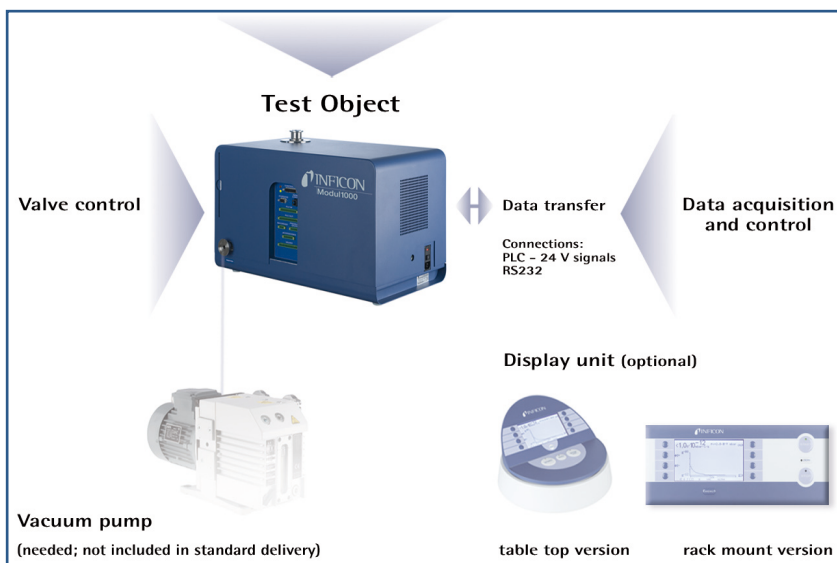

EASY SETTING OF AUTOMATED TEST PROCEDURES

Implemented software functions allow direct valve control of test systems without the need for an additional PLC.

Modul1000 system schematics

FEATURES / BENEFITS AT A GLANCE

- Compact design for easy integration in bench-top or rack systems
- Plug & play installation; flexible interfaces
- Wide range detection system: from 0.1 to $< 5 \times 10^{-12}$ mbar l/s
- Supports any size of foreline pump
- Software algorithm I-CAL provides accurate test results in all measurement ranges
- Wide range power supply
- Integrated test leak
- Flexible control via optional display unit, remote control, PLC or PC
- Self-diagnostics capability
- Low cost of ownership
- Storage of parameter settings for easy data transfer on an integrated, removable I-STICK

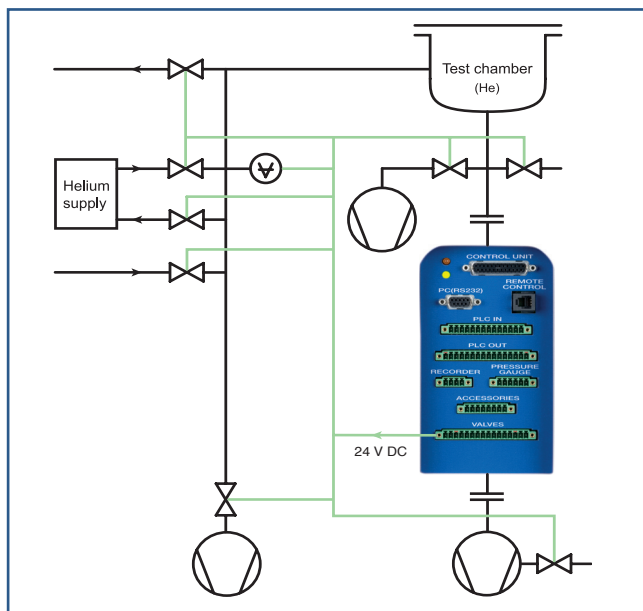

Example: Test station with Helium supply.

Implemented "Commander" software menu for direct control of test systems

SPECIFICATIONS

Minimum detectable leak rate	$< 5 \times 10^{-12}$ mbar l/s
Maximum inlet pressure	0.4 mbar
Operational mode	wide range without crossover (12 decades)
Helium pumping speed at inlet	2.5 l/s
Ion source	2 filaments, Iridium/Yttria-oxide coated
Start-up time	< 3 minutes
Inlet port / Fore-vacuum port	DN 25 KF
Power supply	85 - 265 V, 50/60 Hz
Control inputs	8 x PLC compatible (max. 35 V)
Status / Valve control / Trigger outputs	9 / 11 / 3 x relay contacts (max. 60 V AC / 25 V DC / 1 A)
Chart recorder output lin/log	2 x 0-10 V, programmable
Recommended fore-vacuum pump	2.5 - 16 m ³ /h, wet or dry
Dimensions (width x depth x height)	535 x 350 x 339 mm (21 x 13.8 x 13.4 in)
Weight	30 kg (66 lbs)

ORDERING INFORMATION

	Cat.No.
Modul1000, vacuum version	550-300
Modul1000, vacuum and sniffer version	550-310
Accessories:	
Display unit for table-top use	551-100
Display unit for rack installation	551-101
Connecting cable for display unit, 5 m	551-102
Set of connecting plugs	551-110
Sniffer line SL200	140 05
Hand unit	200 99 022
Connecting cable for hand unit, 4 m	200 99 027

 **UHV TECH SERVICES INC.**

774 Whittier Hwy
Sandwich, NH 03227

Phone: 603-284-6306
203-262-8688

Email: sales@uhvts.com
www.uhvts.com

