

O P E R A T I N G I N S T R U C T I O N S

GA 10.212 / 6.02

Cat. No.
140 50

As of software version
Command computer: 2.1
Control computer : 2.1

UHV TECH SERVICES INC.

774 Whittier Hwy
Sandwich, NH 03227

Phone: 603-284-6306
203-262-8688
Email: sales@uhvts.com
www.uhvts.com



ULTRATEST UL 500 dry

Helium Leak Detector



INFICON-Service

If an appliance is returned to INFICON, indicate whether the appliance is free of substances damaging to health or whether it is contaminated. If it is contaminated also indicate the nature of the hazard. INFICON must return any appliance without a declaration of contamination to the sender's address.

General Note

The right of alterations in the design and the technical data is reserved.

The illustrations are not binding.

Contents

	Page		Page
1	Description		
1.1	General	2.2.3.1	„INSPECT“ Mode
1.1.1	Unpacking	2.2.3.2	„MEASURE“ Mode
1.1.2	Transport at the Customer's Site	2.2.4	„START/RESET MAX“ Key
1.1.3	Purpose	2.2.4.1	„START/RESET MAX“ Key in STANDBY Mode
1.1.4	Modules	2.2.4.2	„START/RESET MAX“ Key in DETECT Mode
1.2	Technical Data	2.2.5	„STOP/VENT“ Key
1.2.1	Physical Data	2.2.5.1	„STOP“ Function
1.2.2	Electrical Data	2.2.5.2	„VENT“ Function
1.3	Technical Description	2.2.6	„ZERO“ Key
1.3.1	Principle of Leak Detection	2.2.7	„CAL“ Key
1.3.2	Double-Entry Turbomolecular Pump	2.2.8	„RATE/CONC“ Key
1.3.3	Forepump Set	2.2.9	„PREC“ Key
1.3.4	Auxiliary Pump	2.2.10	„MAX/ACT“ Key
1.3.5	Mass Spectrometer	2.2.10.1	„MAXIMUM“ Function
1.3.5.1	Ion Source	2.2.10.2	„ACTUAL“ Function
1.3.5.2	Separation System	2.2.11	„FAST/SLOW“ Key
1.3.5.3	Ion Collector	2.2.12	Numeric Keypad
1.3.6	Electronics Modules	2.2.13	„Decimal Point“ Key (.)
1.3.6.1	Electrometer Amplifier	2.2.14	„EXP“ Key
1.3.6.2	Mass Spectrometer Supply Unit	2.2.15	„PLUS/MINUS“ Key (+/-)
1.3.6.3	Turbomolecular Pump Supply Unit	2.2.16	„Arrow LEFT / RIGHT“ Keys
1.3.6.4	Power Distribution Unit	2.2.17	„CLR“ Key
1.3.6.5	Power Conversion Unit	2.2.18	„LIMIT LOW/LIMIT HIGH“ Key
1.3.6.6	Control Unit	2.2.18.1	Operation with only „LIMIT LOW“ Activated
1.3.6.7	Keypad and Display Unit	2.2.18.2	Operation with „LIMIT LOW“ and „LIMIT HIGH“ Activated
1.4	Equipment	2.2.18.3	Manual Ranging in Connection with set Upper and Lower limit
1.4.1	Standard Specification	2.2.19	„OPT“ Key
1.4.2	Accessories	2.2.20	„HELP“ Key
2	Operation	2.2.21	„EXEC“ Key
2.1	Installation of the UL 500 dry	2.2.22	Volume Control
2.1.1	Layout of Controls and Displays	2.2.23	Recorder Output and Remote Control Connection Socket
2.1.2	Preparations for Initial Startup	2.2.24	Pin-out of the Multifunction Socket
2.1.2.1	Electrical Connections	2.2.25	Headset Output
2.2	Description of Controls	2.3	Description of Displays
2.2.1	Power Switch		
2.2.2	„SNIFF/VAC“ Key		
2.2.2.1	Vacuum Mode		
2.2.2.2	„SNIFF“ Mode		
2.2.3	„INSP/MEAS“ Key		

	Page		Page		
2.3.1	Analog Display	26	2.8.1	AUTOTUNE	36
2.3.1.1	Analog Display in Conjunction with „LIMIT LOW/LIMIT HIGH“ Functions . .	26	2.8.2	AUTOZERO	36
2.3.2	Digital Display	26	2.8.3	AUTORANGE	36
2.3.2.1	Digital Display in Conjunction with „ACTUAL“ Function	26	3	Maintenance	38
2.3.2.2	Digital Display in Conjunction with „MAXIMUM“ Function	27	3.1	Scroll pump and diaphragm pump maintenance	38
2.3.3	Limit Value Display (Low and High Limits)	27	3.1.1	Diaphragm pump	38
2.3.4	Status Displays	27	3.1.2	Scroll pump	38
2.3.4.1	Description of Status Displays	27	3.2	Exchanging the Fluorescent Tube behind the Display	38
2.3.5	Alphanumeric Display	27	3.3	Changing the Fuses on the Power Distribution (LV) Front Panel	38
2.3.6	Acoustic Signal	28	3.4	Exchanging the Filter Mat	39
2.4	Startup (First Pumpdown Cycle)	29	3.5	Draining Condensate from the Compressor Buffer Vessel	39
2.5	Operating Modes	30	3.6	INFICON Service	40
2.5.1	Vacuum Mode (VAC)	30	ANNEX 1	Parameter entry mode (PARA MODE)	41
2.5.1.1	Local Leak Detection in the Vacuum Mode	30	ANNEX 2	Operation of the UL 500 dry on mass 2 and 3 (Hydrogen)	42
2.5.1.2	Integral Leak Detection in the Vacuum Mode	31	ANNEX 3	Equipment messages; messages for the operator on the text display	43
2.5.2	„SNIFF“ Mode	32	ANNEX 4	Error messages	45
2.5.2.1	Local Leak Detection in „SNIFF“ Mode . . .	32	ANNEX 5	Declaration of Contamination of Compressors, Vacuum Pumps and Components	49
2.5.2.2	Integral Leak Detection in „SNIFF“ Mode . .	32			
2.5.2.3	Calculation of Standard Leak Rate as a Function of Pressure Differential	33			
2.5.3	„INSPECT“ Mode	33			
2.5.4	„MEASURE“ Mode	33			
2.6	Shutdown	34			
2.7	Calibration	34			
2.7.1	Calibration in the Vacuum Mode	34			
2.7.1.1	Calibration with Internal Calibrated Leak	34			
2.7.1.2	Calibration with External Calibrated Leak	34			
2.7.2	Calibration in the „SNIFF“ mode	35			
2.7.2.1	Calibration with a Known Helium Concentration	35			
2.7.2.2	Calibration of Helium Leak Rate	35			
2.8	Automatic Functions	36			

1 Description

1.1 General

These Operating Instructions contain important information on the functions, installation, operation, troubleshooting and maintenance of the ULTRATEST UL 500 dry.

Before startup of the detector, please read Sections 1.1 and 1.4. For initial startup, follow Sections 2.1 and 2.4 to 2.6.

Important remarks concerning operational safety and protection are emphasized as follows:

Warning



Indicates procedures that must be strictly observed to prevent hazards to persons.

Caution

Indicates procedures that must be strictly observed to prevent damage to, or destruction of, the ULTRATEST UL 500 dry helium leak detector.

Note

Indicates special technical requirements that the user must comply with.

The references to diagrams, e.g. (2/5), consist of the Fig. No. and the Item No. in that order.

1.1.1 Unpacking

Unpack the UL 500 dry immediately after delivery, even if it is to be put into operation at a later date.

Caution

When moving the UL 500 dry pull or push the instrument only at its housing and not at its display unit.

Examine the shipping container for any external damage and then completely remove the packaging materials.

Note

The shipping container and packaging materials must be kept in the event of complaints about damage.

Check that the ULTRATEST UL 500 dry is complete (Section 1.4) and carefully examine it visually.

Examine the display unit to ensure that no damage has occurred.

If any damage is discovered, report it immediately to the forwarding agent and insurer.

If the damaged part has to be replaced, please get in touch with the service department.

1.1.2 Transport at the Customer's Site

For transport of the instrument pull or push it only at the housing and not at the display unit.

Special preparations are required for transportation of the UL 500 dry with a crane.

The set of crane eyes Ref. No. Nr. 200 59 475 contains an extended crane eye to prevent damage to the display unit through the steel wire. Further parts are included for stiffening of the frame:

Clamping pieces

to prevent the dislodging of the crane eyes from the aluminium profile.

Screws

To stiffen the bottom plate. The use of these screws it is not required in connection with the UL 500 dry.

Moreover, it is recommended to use a transport frame so that the lifting forces are applied perpendicularly to the work panel of the UL 500 dry and the profiles of the UL 500 dry are subjected only to pulling forces.

Caution

The exclusive use of standard crane eyes will result in damage to the display unit. The additional strengthening measures using the clamping pieces and screws must be introduced on the UL 500 dry to prevent damage to the instrument.

1.1.3 Purpose

The ULTRATEST UL 500 dry helium leak detector is a helium leak indicator based on the mass-spectrometric principle of detection. The UL 500 dry can be used to carry out leak tests on test objects of virtually all sizes and up to the largest volumes.

All equipment needed for leak detection is supplied with the UL 500 dry.

1.1.4 Modules

The UL 500 dry comprises three main assemblies (see Fig.1) :

Operating level

- keypad (1/1)
- display unit (1/2)
- work panel (1/3)

Measurement and control level

- valve block (1/4)
- Compressed air supply (1/5)
- high vacuum plug-in (1/10)
- electronics plug-in (1/11)

- IPump level
- Diaphragm pump (1/7)
 - TMP 35 LS turbomolecular pump (1/6)
 - 600 DS scroll pump (1/8)
 - Mains transformer (1/9)
 - Connections for peripheral equipment

Pumpdown times until ready for leak detection	
without additional volume	6 s
with test-object volume 1 l	6 s
with test-object volume 50 l	150 s

Response times:	
up to test-object volumes of 10 l	≤ 1 s
up to test-object volumes of 50 l	≤ 5 s
permissible temperature range	10 to 30 °C

1.2 Technical Data

Safety

The instrument meets the specifications of protection class 1 according to VDE 0411 (IEC 348). The UL 500 dry conforms with the Directive on Machinery according to CE.

Electromagnetic interference

The instrument meets the requirements of VDE 0871, limit curve B.

1.2.1 Physical Data

Max. measurable helium leak rate	10 mbar·l·s ⁻¹
Min. measurable leak rate	5·10 ⁻¹¹ mbar·l·s ⁻¹
with time constant	< 1 s
Max. inlet pressure	
for quantitative measurement	100 mbar
Max. total gas flow at inlet with limit of detection	
2·10 ⁻¹⁰ mbar·l·s ⁻¹	0.1 mbar·l·s ⁻¹
1·10 ⁻⁹ mbar·l·s ⁻¹	0.5 mbar·l·s ⁻¹
1·10 ⁻⁶ mbar·l·s ⁻¹	400 mbar·l·s ⁻¹
Time until ready to display	≤ 5 min
Detectable masses	2, 3, 4 amu

Display capabilities for leak rate:	
Quasi-analog display for leak rate:	
360° circular indicator, with logarithmic scale,	
1 decade per revolution, 45 segments	
correspond to 5 % resolution of indicated value	
Bar scale for leak rate exponent	
exponent display from -10 to +3	
Digital display for leak rate	2 digits,
	2-digit exponent, sign

Units displayed	ppm
	mbar·l·s ⁻¹
	atm·cc·sec ⁻¹ (US unit)
	Pa·m ³ ·s ⁻¹

Note

The measurement units displayed can only be changed in a special operating mode of the instrument (PARAMODE). Refer to Annex 1.

Two „limit“ displays to indicate the low and high range limits.

Display capabilities for status:	
Light spots for display status	
MAX/ACT	storage of max. value
FAST/SLOW	smoothing of measured value
BACKGRND	suppression of zero
Light spots for leak detection status	
PREC	sensitivity
VAC/SNIFF	operating mode

Key to Fig. 1

- 1 Keypad
- 2 Display unit
- 3 Work panel
- 4 Valve block
- 5 Compressed air supply
- 6 TMP 35 LS turbomolecular pump
- 7 Diaphragm pump
- 8 600 DS scroll pump
- 9 Mains transformer
- 10 High vacuum plug-in
- 11 Electronics plug-in

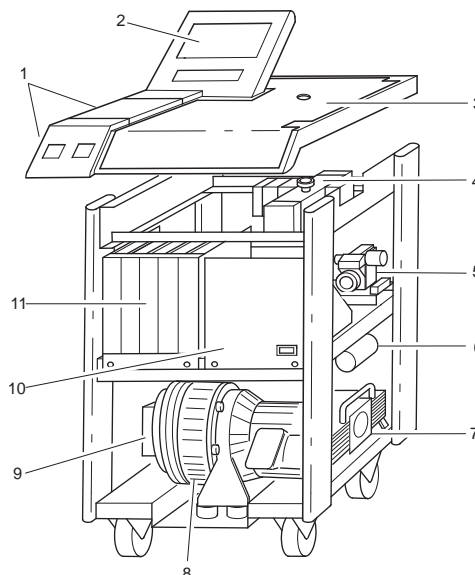

Fig. 1 Modules

STOP/VENT CAL CAT2	status of test object request for calibration cathode 2
Noise when running	max. 58 dBA
Dimensions (H x W x D)	110.5 x 62.7 x 77.5 cm
Weight	205 kg
Cat. No.	140 50

1.2.2 Electrical Data

The mains voltage setting is fixed in the factory and can not be changed. When ordering you may specify either of the following:

- 380 V; 50 Hz, 3-phase or
- 208 V; 60 Hz; 3 phase

In case of other mains supply voltages please contact Inficon first.

Mains frequency	50/60 Hz
Nominal power	$P_N = 1.7 \text{ kW}$
Max. turn-on power	$P_S = 5.0 \text{ kW}$
Mains connection for QUICKTEST	220 V a.c.

Caution This connection always carries 220 V a.c. independently of the mains voltage.



Recorder output	For recorder with an internal resistance of at least. 2.5 k Ω
1. Leak rate, linear	1.0 - 9.9 V per decade
Leak rate exponent	0.5 V per decade beginning with 1 V at $10^{-10} \text{ mbar-l-s}^{-1}$
2. Leak rate, logarithmic	0.5 V per decade beginning with 1 V at $10^{-10} \text{ mbar-l-s}^{-1}$
3. Inlet pressure and fore pressure, logarithmic	0.5 V per decade beginning with 1 V at 10^{-3} mbar
Headset output	
internal resistance of headset	min. 8 Ω ,
output power	max. 500 mW

1.3 Technical Description

1.3.1 Principle of Leak Detection

The UL 500 dry operates on the counterflow principle, i.e. helium diffuses against the turbomolecular pump's direction of flow into the mass spectrometer, while heavy gases, especially water vapours, are held back (mass-dependent compression capacity).

A cold trap in conjunction with liquid nitrogen is thus not needed.

A special feature of the UL 500 dry is the double-entry turbomolecular pump, whose inlet side at the test object ensures short response times.

The UL 500 dry thus achieves pumping and response times which are shorter than for the full-flow technique involving liquid nitrogen, without any appreciable reduction of sensitivity.

1.3.2 Double-Entry Turbomolecular Pump

The double-entry turbomolecular pump of the UL 500 dry combines in a single housing two turbomolecular pumps driven by a common motor.

The two turbomolecular pumps pump in opposite directions into a common forepressure connection.

One side of the turbomolecular pump (compression side) produces from the helium pressure in the foreline the helium pressure that is detected in the mass spectrometer. The pump's stable compression capacity for helium is exploited for this purpose. This capacity, together with the pumping capacity of the forepump, determines the sensitivity of the system.

The other side of the turbo pump (pump side) serves as a high-vacuum pump to evacuate the inlet resp. the test object.

The double-entry turbomolecular pump is a special pump for the UL 500 dry; its designation is TURBOVAC 151 LS.

1.3.3 Forepump Set

The forepump set consists of a TMP 35 LS and a MV 2 diaphragm pump. It generates from the helium flow into the UL 500 dry a proportional helium pressure. In doing so, the stable compression characteristics for helium offered by this pump set are utilised. Its magnitude together with the compression of one stage of the turbomolecular pump (2/6) determine the sensitivity of the arrangement. In order to improve the response characteristic and to improve the reduction of the background, a purge gas inlet which is permanently open is provided between the MV 2 diaphragm pump and the TMP 35 LS.

For data and information on the forepump set refer to the corresponding Operating Instructions.

1.3.4 Auxiliary Pump

The auxiliary pump (2/14) which has been built into the UL 500 dry evacuates the connected test object down to a pressure at which it may be linked to the intake side of the turbomolecular pump. Additionally, this pump supports the pump combination consisting of TMP and diaphragm pump in the leak detection mode in the case of larger quantities of gas coming from the test object.

A scroll pump (600 DS) is used in the UL 500 dry as the auxiliary pump. For all data on this pump please refer to the corresponding Operating Instructions.

1.3.5 Mass Spectrometer

The main components of the mass spectrometer (MS) are an ion source, a magnetic separation system and an ion collector (Fig. 3).

The ion source ionizes neutral gas particles, thereby generating an ion beam. Positively charged ions are accelerated out of the ion source and subsequently reach the magnetic field. There they are deflected into an orbit whose radius is dependent on the mass-to-charge ratio of the ions.

Only the helium ions meet the separation conditions and reach the ion collector, where they can be measured as current by the electrometer amplifier.

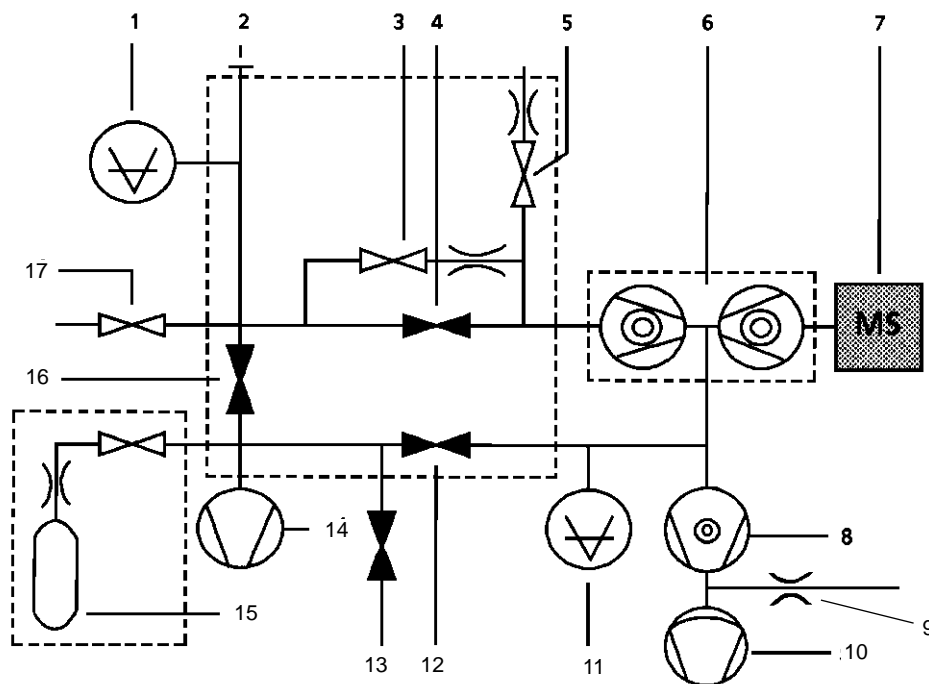

Key to Fig. 2

- | | |
|---|--|
| 1 Total-pressure measuring point, at the inlet (P1) | 10 Diaphragm pump |
| 2 Test connection | 11 Total pressure gauge, forevacuum (P2) |
| 3 Bypass valve of inlet valve | 12 Coupling valve (VK) |
| 4 Inlet valve (VE) | 13 Purge gas valve (VS) |
| 5 Venting valve for turbomolecular pump (VF2) | 14 Scroll pump (auxiliary pump) |
| 6 Double-entry turbomolecular pump | 15 Calibrated leak with associated valve (VT) |
| 7 Mass spectrometer | 16 Valve associated to the auxiliary pump (VH) |
| 8 Turbomolecular pump | 17 Venting valve for venting the test object (VF1) |
| 9 Purge gas orifice | |

Fig. 2 Functional diagramm of UL 500 dry

1.3.5.1 Ion Source

Electrons with 80 eV energy are used in the ion source. The electrons emerging from the hot cathode (3/1) are attracted by the positive anode (3/2). However, they do not immediately reach the anode (3/2), but oscillate to and fro for several times until finally reaching the wire spiral of the anode (3/2).

In this way the electrons ionize gas atoms through impact. These ions are extracted from the ion source by an extractor screen (3/10) connected to ground and enter the magnetic separation system.

The anode is heated during run-up of the UL 500 dry to prevent polymerized hydrocarbon deposits (insulating layers that may impair the sensitivity).

After run-up, the anode is no longer heated as the operating temperature of the ion source (cathode heating) is sufficient.

The cathodes (3/1) and (3/3) consist of iridium tape coated with thorium oxide. Owing to this thorium coating, the iridium filaments operate at a much lower temperature than tungsten ones and possess excellent resistance (burnout resistance) to embrittlement, oxygen, water vapour and hydrocarbons.

Caution Halogens or halogen-containing substances may adversely affect the service life of the cathodes.

1.3.5.2 Separation System

A magnetic sector field (3/8) with 180° deflection is used as separation system. Owing to the inhomogeneity of the magnetic field vertically in relation to the ion beam, additional concentration is achieved in this direction (Z-focusing), resulting in a high sensitivity.

The intermediate screen (3/9) ensures additional separation of unwanted ions of other gases.

1.3.5.3 Ion Collector

The ion collector (3/5) consists of a suppressor and the collector proper.

The suppressor has a positive potential slightly below the anode potential. It is designed to prevent scattered ions with a lower energy than required from reaching the collector. Resolution at low detection rates is thus improved.

The collector collects the incoming ions and neutralizes them. The corresponding current reaches the subsequent amplifier.

1.3.6 Electronics Modules

See Fig. 4.

1.3.6.1 Electrometer Amplifier

The electrometer amplifier amplifies the current generated at the ion collector of the mass spectrometer. Its gain can be changed in three stages. Changeover and processing of the analog output voltage are accomplished by the control unit. The detection limit in the most sensitive range is approx. $4 \cdot 10^{-15}$ A.

1.3.6.2 Mass Spectrometer Supply Unit

This unit generates all voltages and currents needed for operating the mass spectrometer:

- Anode heater
- Cathode heater
- Anode voltage
- Suppressor voltage

Malfunctions in the mass spectrometer are detected and communicated to the control unit. The latter monitors the mass spectrometer supply unit.

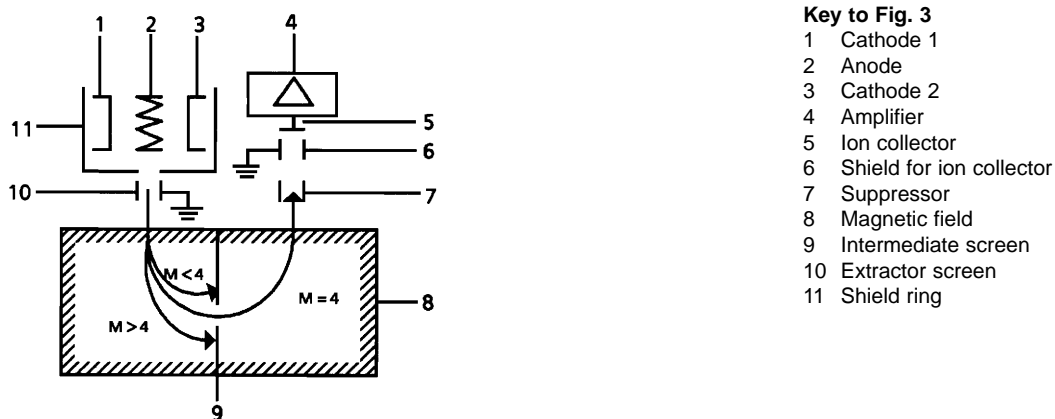

Key to Fig. 3

- 1 Cathode 1
- 2 Anode
- 3 Cathode 2
- 4 Amplifier
- 5 Ion collector
- 6 Shield for ion collector
- 7 Suppressor
- 8 Magnetic field
- 9 Intermediate screen
- 10 Extractor screen
- 11 Shield ring

Fig. 3 Schematic representation of the mass spectrometer

1.3.6.3 Turbomolecular Pump Supply Unit

This unit controls and monitors the turbomolecular pump. It is in turn monitored by the control unit, which thus controls the pump.

1.3.6.4 Power Distribution Unit

All circuits needed for operating and monitoring the rotary-vane pumps and valves are contained in the power distribution unit. This unit is in turn controlled by the control unit.

1.3.6.5 Power Conversion Unit

This unit generates from the AC supplied via the mains transformer all the DC supply voltages needed for operating the electronics units.

1.3.6.6 Control Unit

The control unit is the central component of the leak detector's electronics system. It controls and monitors all other modules. Its microprocessor is thus constantly informed of the status of the entire leak detector and can act accordingly. The control unit is linked to the operation and display unit so as to receive operator commands and to output measured values and messages.

1.3.6.7 Keypad and Display Unit

This unit serves the purpose of communication with the operator. It receives commands entered at the keypad and outputs measured values and messages via the display.

Like the control unit, this unit possesses a microprocessor. The two processors are in constant mutual contact for the purpose of exchanging commands and measured values.

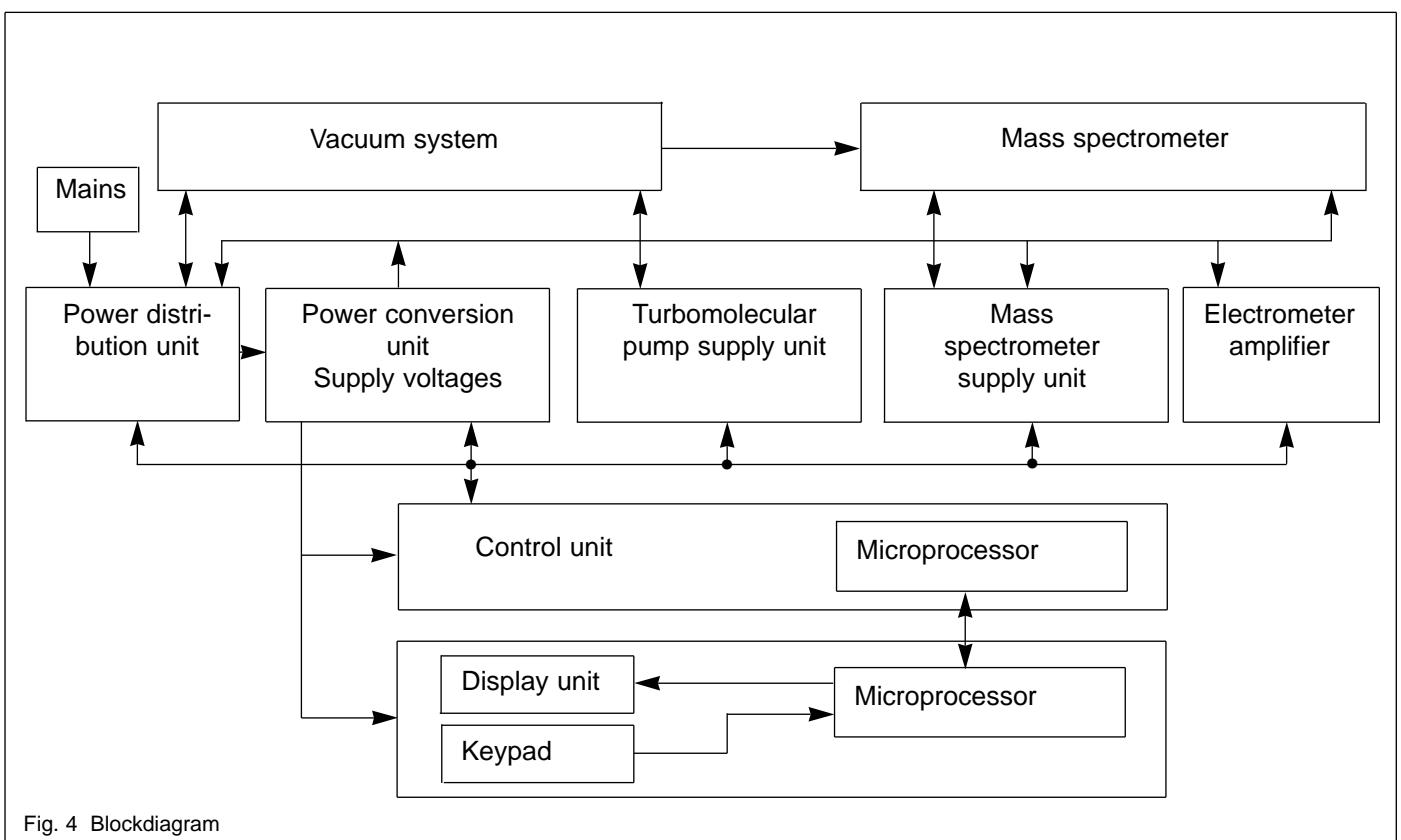

Fig. 4 Blockdiagram

1.4 Equipment

1.4.1 Standard Specification

The ULTRATEST UL 500 dry helium leak detector is delivered ready for use.

- UL 500 dry with built-in display unit and with power cord attached
- Set of gaskets
- Set of tools in bag
- Set of fuses
- Folder with operating instructions:
 - TMP 35
 - MV 2 diaphragm pump
 - 600 DS scroll pump
 - Turbomolecular pump TURBOVAC 151 LS = Operating Instructions GA 05.101
 - Spare parts list = ET 10.204
- 6-way plug for the recorder output, Ref. No. 500 17 119
- Centering ring with grid insert for the inlet flange, Ref. No. 411 70 121

1.4.2 Accessories

	Cat.No. / Ref. No.
Calibrated leak TL 9	155 81
Calibrated leak TL 8	165 57
Calibrated leak TL 6	155 66
Calibrated TL 4	155 65
Calibrated TL 4 - 6	155 80
Reducer DN 40/16	183 89
Helium spray gun for helium, with 5 m hose	165 55
Standard sniffer	155 90
Helium sniffer Quicktest	155 78
Headset	165 07
Interface V.24/RS 232 C	156 05
Trigger outputs	156 06
Set of crane eyes	200 59 475
Antistatic work plate	200 59 665
Air filtering mat for the rear	200 62 006
Remote control	upon request
Air inlet for venting valve	upon request

2 Operation

2.1 Installation of the UL 500 dry

When moving the UL 500 dry pull or push it only at its housing and not at the display.

When lifting the UL 500 dry with a crane, special preparations are required. See Section 1.1.2.

Moreover, it is recommended to use a transport frame so that the lifting forces are applied perpendicularly to the work panel of the UL 500 dry and the profiles of the UL 500 dry are subjected only to pulling forces.

Caution The exclusive use of standard crane eyes will result in damage to the display unit. The additional strengthening measures using the clamping pieces and screws must be introduced to the UL 500 dry to prevent damage to the instrument.



2.1.1 Layout of Controls and Displays

An overview of the controls on the top and front of the UL 500 dry is given in Fig. 5.

Caution The mains socket (5/6) for the QUICK-TEST always carries 220 V a.c!



In addition to the above controls (see Fig. 5) at the top and front of the UL 500 dry (6/4), the headset connection (6/2), the loudspeaker (6/3), the loudspeaker volume control (6/1), the recorder connection socket (6/5) and the V.24 / RS 232 C interface connection socket (6/6) are located at the back of the display unit (6/4).

Note

- The controls on the control unit are shown in Fig. 7
- The displays on the display unit are shown in Fig. 8.

Key to Fig. 5

- 1 ON/OFF power switch
- 2 START/STOP key
- 3 Operating unit
- 4 Display unit
- 5 Connection flange for test objects
- 6 Mains socket for QUICKTEST

Important

The mains socket for the QUICK-TEST always carries 220 V a.c!

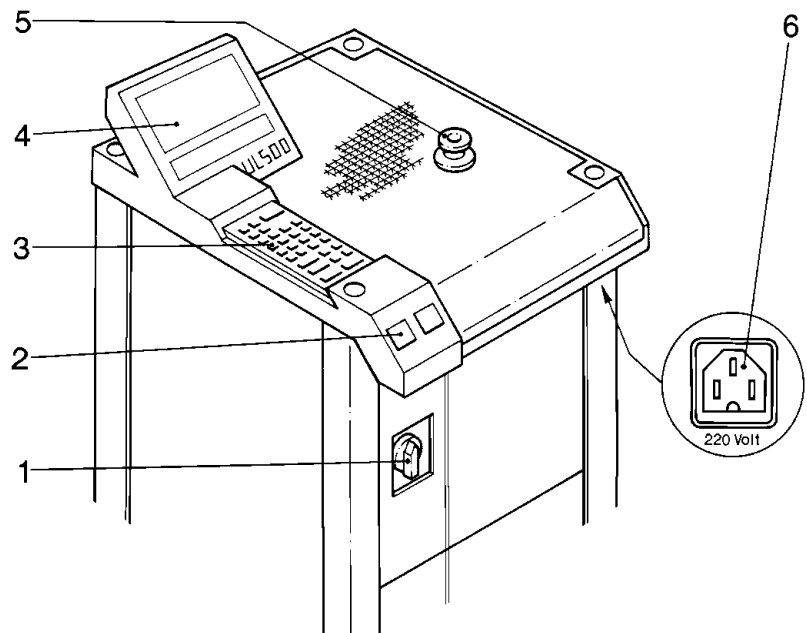
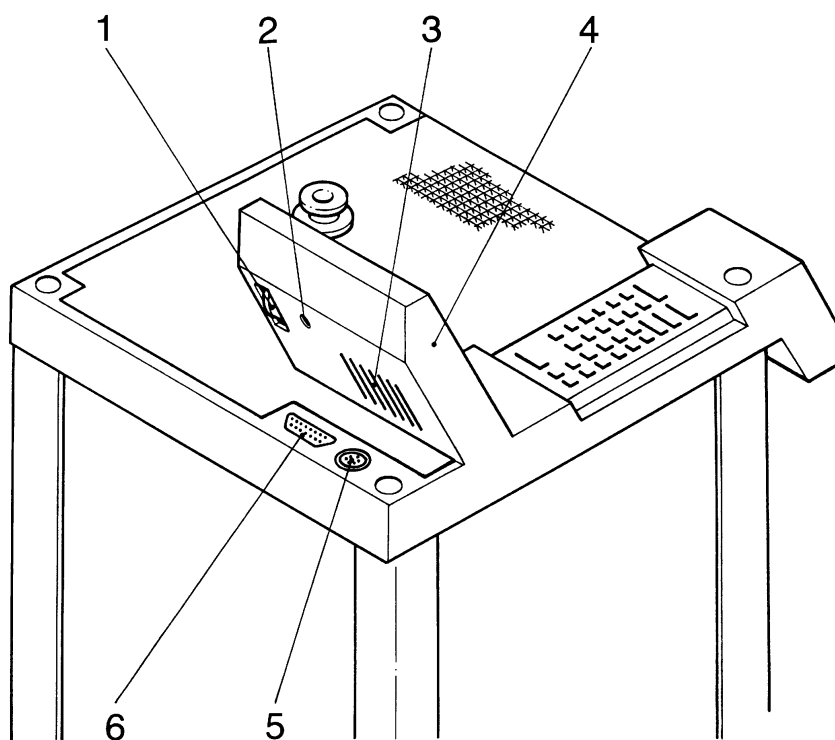

Fig. 5 Controls of UL 500 dry



Key to Fig. 6

- 1 Volume control
- 2 Headset connection
- 3 Loudspeaker
- 4 Display unit
- 5 Connection socket for a recorder
- 6 Connection socket for V.24 / RS 232 C interface and trigger relays

Fig. 6 Back of display unit

Key to Fig. 7

- | | |
|---|---|
| <ul style="list-style-type: none"> 1 HELP
Not used during normal operation. 2 OPT
Start of an optional input / start of an optional operating mode. Input of optional parameters. 3 EXEC
Termination of an input and execution of the relevant command. Acknowledgement of a message by the operator. 4 CLR
Cancellation of the last function entered. 5 EXP
Setting the cursor to enter numbers in the exponent panels. 6 +/-
Changing the sign when entering a number. 7 Arrow pointing to the right
Moving the cursor (indicating the input position) to the right. Moving a lengthy display text further to the right. 8 Arrow pointing to the left
Moving the cursor (indicating the input position) to the left. Moving a lengthy display text back to the left. 9 FAST/SLOW
Switches the display to either fast or slow operating mode. 10 RATE/CONC
Switches the display to indicate either leak rate or helium concentration. 11 MAX/ACT
Switches the digital display to either „Retain the last maximum“ or „Display the currently measured value“. | <ul style="list-style-type: none"> 12 PREC
Enables or disables the most sensitive measuring range for auto-ranging. 13 ZERO
Transfers the currently measured value to the display as „zero“. 14 STOP/VENT
Terminates the pumping or measuring operation in progress. When pressed for longer than 2 s, it opens the inlet venting valve. 15 START/RESET MAX
Starts the pumpdown and measurement operation. Transfer of currently measured value to the digital display and search for next maximum. 16 CAL
Starts the internal or external calibration sequence. 17 INSP/MEAS
Activates either the search mode or the measurement mode of the leak detector. 18 SMIFF/VAC
Activates either the sniffing mode or the vacuum mode of the leak detector. 19 Point
Input of the decimal point when entering a number. 20 Numeric keypad
Digits 0...9 21 LIMIT HIGH
Input of the upper limit of the measuring range to be displayed. 22 LIMIT LOW
Input of the lower limit of the measuring range to be displayed. |
|---|---|

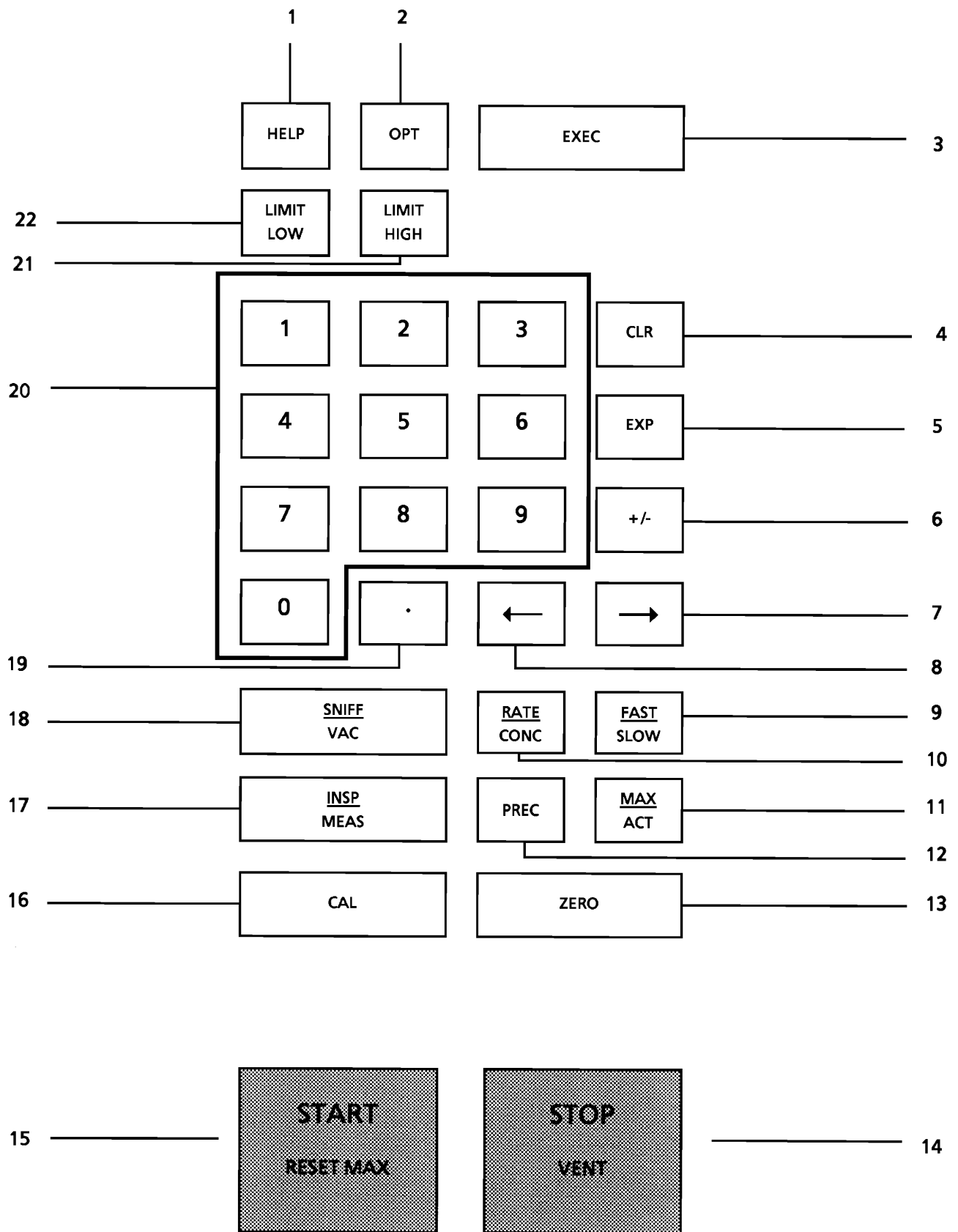
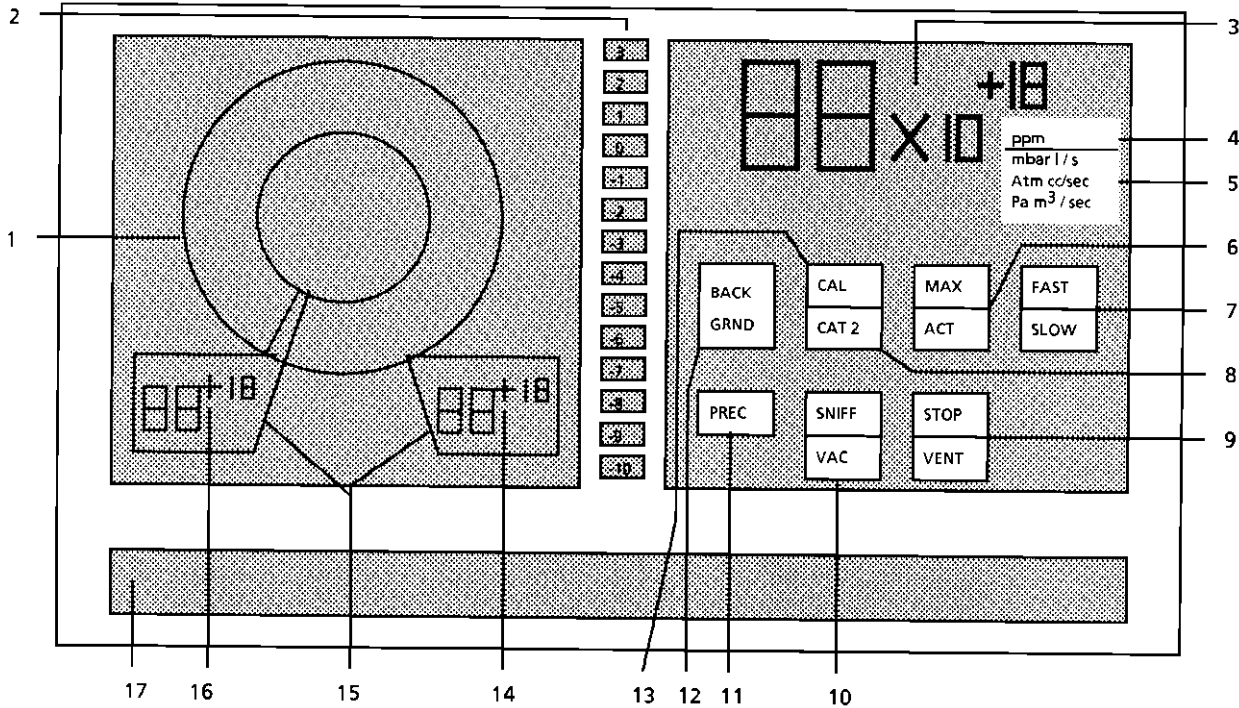

Fig. 7 Operating unit



Key to Fig. 8

- 1 Circular **quasi-analog display** of the leak rate in the „Inspect“ and „Measure“ modes. One revolution corresponds to one decade of the measuring range. Quasi-analog display of a measurement interval defined with the LIMIT values.
- 2 **Exponent scale**
For quasi-analog display of leak rate.
- 3 **Digital display of the measured value** as leak rate or concentration in the „Measure“ mode with mantissa and exponent.
- 4 **Unit „ppm“** for „Concentration“ mode.
- 5 **Units** for „Rate“ mode.
- 6 **MAX/ACT**
Indicates the current operating status of the digital display.
- 7 **FAST/SLOW**
Indicates the current speed of overall display reaction.
- 8 **CAT 2**
Informs the operator that the second cathode of the ion source has been put into service.
- 9 **STOP/VENT**
Indicates the current operating status of the leak detector.
- 10 **SNIFF/VAC**
Indicates the current operating mode of the leak detector.
- 11 **PREC**
Indicates that the PRECISION measuring range for AUTO-RANGING has been enabled.
- 12 **BACKGRND**
Indicates that zero has been shifted for the displayed measured value.
- 13 **CAL**
Indicates that the operator should perform calibration.
- 14 **Digital display** for indicating and entering the high limit of a restricted measurement interval.
- 15 **Marks** for LIMIT LOW and LIMIT HIGH on the display in the interval measurement mode.
- 16 **Digital display** for indicating and entering the low limit of a restricted measurement interval.
- 17 **Alphanumeric display** line to show messages for the operator and to check the input of parameters by the operator.

Fig. 8 Display unit

Key to Fig. 9

- 1 Back panel of UL 500 dry
- 2 Terminal strip
- 3 Plug-in jumpers
- 4 Transparent plastic plate
- 5 Mains cord
- 6 Exhaust for the MV 2 diaphragm pump
- 7 Exhaust for the 600 DS scroll pump
- 8 Purge gas and venting valve connection Exhaust
- 9 Sound adsorber
- 10 Label giving the electrical data
- 11 Plate with serial number

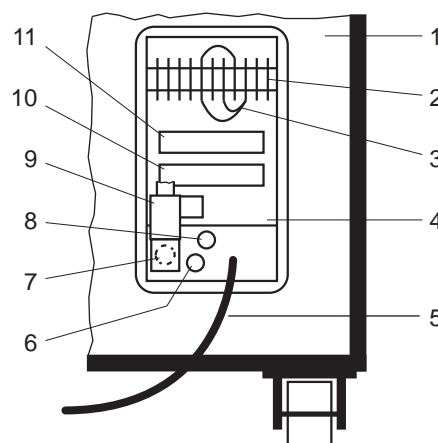

Fig. 9 Mains connection, name plates and exhaust connections

2.1.2 Preparations for Initial Startup

The UL 500 dry is delivered ready for use.

Caution



The mains voltage setting on the UL 500 dry is set in the factory to the mains voltage specified in the order (380 V; 50 Hz; 3-phase or 208 V; 60 Hz; 3-phase).

In rooms with helium concentrations significantly above 5 ppm fresh air should be supplied via hose lines and connections (9/6), (9/7) and (9/8).

Note

Before connecting the UL 500 dry to the mains, check whether the mains voltage matches the voltage required (see Section 2.1.2.1).

2.1.2.1 Electrical Connections

Note

In general, the currently valid VDE 0100 regulations must be observed.

The transformer integrated in the UL 500 dry permits an universal adaptation to mains voltages used throughout the world, see Section 1.2.2. This is achieved by inserting several plug-in jumpers (9/3) into a terminal strip (9/2). The required position depending on the local mains voltage is given in Fig. 10.

A connection diagram for the different mains voltages according to Fig. 10 is also given inside the UL 500 dry on its rear panel.

The mains voltage is adapted on terminal strip (9/2) at the rear of the UL 500 dry above the inlet for the power supply cord (9/5) and behind a transparent plastic plate (9/4). The factory set mains voltage is shown on the information label mounted there.

Caution



The equipment voltage printed on the information label must correspond to the available mains voltage.

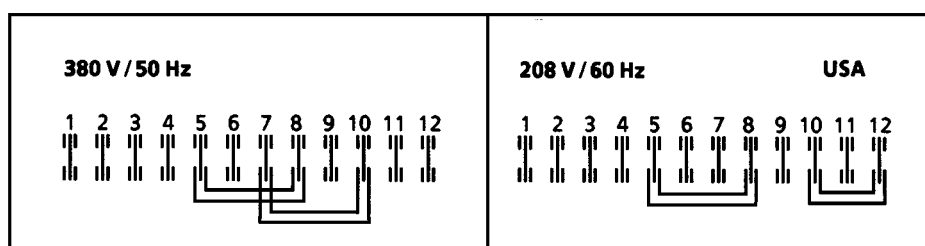

Fig. 10 Jumpers on the terminal strip for adaptation to different mains voltages

2.2 Description of Controls

Note

- The controls on the control unit are shown in Fig. 7
- The displays on the display unit are shown in Fig. 8.

The UL 500 dry is designed for maximum simplicity and clarity of operation. Hence most of the control operations that can be executed via the keys, are supported by displays. Apart from the information in the following, descriptions of the individual key functions, the meanings of the displays are explained in Section 2.3. Also refer to:

- the list of controls: see Fig. 7,
- the list of displays: see Fig. 8.

2.2.1 Power Switch

The entire leak detector is switched on by actuating the power switch.

The UL 500 dry first conducts a selftest of individual modules. If concluded with no faults, the pumps are switched on. After the turbomolecular pumps have run up (approx. 4 min), the UL 500 dry is ready to operate.

The UL 500 dry employs the alphanumeric display (8/17) to inform the operator of all automatically executed actions (see Section 2.4).

Note

During the selftest the turbopump venting valve VF2 is briefly actuated for testing purposes.

After completion of run-up the UL 500 dry is set automatically to the operating condition at the time it was switched off. All required parameters for this are stored in a battery-backed-up memory. (The life of the battery is 6 years approx.)

The following parameters are stored when switching off:

- LIMIT LOW value
- LIMIT HIGH value
- LIMIT LOW ON/ OFF
- LIMIT HIGH ON/OFF
- INSP or MEAS
- SNIFF or VAC
- RATE or CONC
- PREC on or off
- Status of the alphanumeric display (display P 1, P 2)
- Status of the recorder output (Output of P 1, P 2; leak rate linear or logarithmic)
- Status of the V.24 / RS 232 C option
- Status of the trigger option
- Equipment-specific parameters, programmed in the PARA MODE (see Annex 1)
- Factors from OPT CALEMV
- Anode voltage (value determined through AUTOTUNE)

2.2.2 „SNIFF/VAC“ Key

SNIFF
VAC

Note

The SNIFF/VAC key (7/18) may only be actuated in the STANDBY mode.

The „SNIFF/VAC“ key (7/18) is employed to select the basic operating modes SNIFF and VAC.

Changeover between SNIFF and VAC necessitates a few changes in the control sequence of the UL 500 dry. The changeover is not carried out until acknowledged by pressing the „EXEC“ key (7/3). The operator receives the necessary information via the alphanumeric display line (8/17) and via the display „SNIFF“ and „VAC“ (8/10). The display of the mode still valid is lit, that of the mode which can be selected flashes at the same time.

2.2.2.1 Vacuum Mode

In this operating mode, leak detection can be conducted with the basic UL 500 dry unit.

The test object is evacuated with the integrated pumps of the UL 500 dry and sprayed with helium from the outside to localize leaks (also see Section 2.5). The operating mode is indicated by the display VAC (8/10) lighting up. The indicated measured values are always leak rates; it is possible for the display to indicate either of the following units (8/4) or (8/5):

mbar·l·s⁻¹,
Atm·cc·sec⁻¹ (USA unit)
Pa·m³·s⁻¹

These units are default units of the UL 500 dry and they can only be changed in a special operating mode (PARA MODE, see Annex 1).

2.2.2.2 „SNIF“ Mode

In this operating mode, the UL 500 dry is normally operated with an external sniffer unit. This mode is indicated in the SNIFF display panel (8/10). It is possible to indicate the measured values as a helium concentration (ppm) or as a leak rate (mbar·l·s⁻¹) which can only be changed in the PARA MODE. The RATE/CONC (7/10) key is used for the switchover.

2.2.3 „INSP/MEAS“ Key

INSP
MEAS

The INSP/MEAS key (7/17) can be pressed to choose between the INSPECT mode and the MEASURE mode. The major difference between them is the measurement accuracy.

2.2.3.1 „INSPECT“ Mode

Starting from the MEASURE mode, the INSPECT mode is activated by pressing the „INSP/MEAS“ key (7/17) and

acknowledging the function with the „EXEC“ key (7/3).

The INSPECT mode gives the operator a quick overview of existing leaks and their location, without a quantitative display of a precise measured value. The representation is only via the quasi-analog display (8/1) and (8/2). The digital display (8/3) is deactivated in this operating mode, thus eliminating the possibility of switching over from „Retain the last maximum“ (MAX) to „Display the currently measured value“ (ACT) (see Section 2.2.10). It is not possible to calibrate the UL 500 dry in the INSPECT mode (see Sections 2.2.7 and 2.7). The PRECISION function (7/12) cannot be selected.

2.2.3.2 „MEASURE“ Mode

Starting from the INSPECT mode, the MEASURE mode is activated by pressing the INSP/MEAS key (7/17) and acknowledging the function with the „EXEC“ key (7/3).

The MEASURE mode is employed for quantitative determination of a leak. The measured leak rate is indicated both on the quasi-analog display (8/1) and (8/2) and on the digital display (8/3).

If possible, the UL 500 dry should be calibrated before operating it in the MEASURE mode (also see Sections 2.2.7 and 2.7).

2.2.4 „START/RESET MAX“ Key

 The „START/RESET MAX“ key (7/15) assumes either of two functions depending on the main status of the UL 500 dry.

2.2.4.1 „START/RESET MAX“ Key in STANDBY Mode

Starting from the STANDBY mode of the UL 500 dry, evacuation of a connected test object is initiated by pressing the „START“ key. The UL 500 dry operates with automatic measuring range selection, the AUTORANGING (see Section 2.8.3).

The measured values appear on the display in the following fashion:

- The circular display (8/1) in conjunction with the exponential scale (8/2) shows the current leak rate.
- The digital display (8/3) appears only in the MEASURE mode (7/17). Its function still depends on the type of display selected via MAX/ACT (7/11).

The message „DETECTING INSPECT“ or „DETECTING MEASURE“ appears on the alphanumeric display (8/17) if no special function of this display has been selected by pressing the „OPT“ key (7/2).

2.2.4.2 „START/RESET MAX“ Key in DETECT Mode

Starting from the DETECT mode already initiated, i.e. after having already pressed the „START“ key once, and with display type „Retain the last maximum“ (7/11) activated, the RESET MAX function is executed every time the key is pressed.

From the point of actuation onward, all current leak rate values are displayed which are higher than a preceding one. The next max. value stored in the display.

Note

If the ACT display type (display of the currently measured value) is activated, pressing the „RESET MAX“ key is ineffectual.

2.2.5 „STOP/VENT“ Key

 The „STOP/VENT“ key (7/14) has either of two functions depending on how long it is pressed.

2.2.5.1 „STOP“Function

Starting from the DETECT mode of the UL 500 dry, evacuation of the test object is interrupted by pressing the „STOP“ key (7/14). To do so, the key must be pressed for less than 1.1 s. The unit switches to the STANDBY mode, i.e. all valves are closed.

Next a correction of the internal Zero level is carried out for the ranges FINE 3 and PREC. For this the coupling valve VK is opened briefly. At the same time the last internal leak rate signal is displayed which was determined as the offset after the last Zero determination in the two measurement ranges.

This takes approximately 10 s. Then the purge gas valve VS is opened automatically.

After Zero correction the detection limit is displayed.

The operator is informed of the status by the „STOP“ display (8/9) lighting up. In addition, the message

„STANDBY FOR MEASURE“ or „STANDBY FOR INSPECT“

appears in the alphanumeric display line (8/17) if no special function of the display has been selected by pressing the OPT key (7/2).

Note

If the UL 500 dry is already in the STANDBY mode, pressing the STOP key again briefly will let the UL 500 dry determine the background once more.

2.2.5.2 „VENT“ Function

The VENT function is achieved only if the „STOP/VENT“ key (7/14) is held down for more than 1.1 s. After this period the inlet vent valve VF1 (2/17) is opened. The

VENT indicator (8/9) lights up to report this operating mode. The valve VF1 can be closed again by:

- Briefly pressing the „STOP/VENT“ key again. The UL 500 dry then enters the STANDBY mode.
- Pressing the „START/RESET MAX“ key. The UL 500 dry then enters the DETECT mode.

2.2.6 „ZERO“ Key

ZERO A constant leak rate display can be suppressed by means of the ZERO function such as for example a constant helium background of a test sample.

The ZERO function is only active in the DETECT mode, i.e. it is not possible to suppress internal backgrounds of the UL 500 dry itself. This is done by pressing the „STOP“ key. See Section 2.2.5.1. Pressing the „ZERO“ key (7/13) initiates storage of the current leak rate as „Zero“ without changing the internal Zero.

Only values above this Zero are displayed, resulting in enhanced resolution of the displayed measurement signal.

If measured values occur that are below the stored zero-point, an automatically floating zero-adaptation initiates storage of these negative leak rates as new zero points.

To draw the operator's attention to the suppressed background, the red warning indicator BACKGROUND (8/12) lights up. The enhanced resolution is limited by the measurement accuracy of the UL 500 dry.

The zero, set through the ZERO function is derived from the actually measured value by:

- Setting the measured-value mantissa to 0.0.
- Shifting the measured-value exponent by one decade.

Example:

Measured value $7.4 \cdot 10^{-3}$ after pressing the „ZERO“ key:
Display $0.0 \cdot 10^{-4}$ Exceptions:

- Normal AUTORANGING: At leak rates under $1.0 \cdot 10^{-8}$ mbar·l·s⁻¹ the exponent is not switched over any more.
- AUTORANGING with PRECISION: At leak rates under $2.0 \cdot 10^{-10}$ mbar·l·s⁻¹ the exponent is not switched over any more.

The ZERO function is deactivated by pressing the ZERO key again.

The ZERO function is automatically deactivated as soon as the STOP/VENT key (7/14) is actuated.

Note

The ZERO function acts only upon the display and not the recorder output.

2.2.7 „CAL“ Key

CAL Internal or external calibration is initiated by pressing the „CAL“ key (7/16).

The UL 500 dry then controls all subsequent steps automatically.

The UL 500 dry discerns automatically between internal calibrated leak and external calibrated leak which is connected to the inlet flange, depending on the operating mode at the point of entering the CAL command:

- Pressing the „CAL“ key (7/16) in the DETECTING mode: external calibration
- Pressing the „CAL“ key (7/16) in the STANDBY mode: Internal calibration

If an external calibration is to be performed the calibrated leak has to be connected to the inlet flange beforehand.

After pressing the „CAL“ key it is still possible to switch over between internal and external calibration by pressing „START“ (7/15) and „STOP“ (7/14).

The sequence varies depending on the operating mode of the UL 500 dry (also see Section 2.7.2).

Note

- After actuating the „CAL“ key (7/16), the initiation of calibration must additionally be acknowledged by pressing the „EXEC“ key (7/3).
- This initiation and the running process can be terminated by pressing the „CLR“ key (7/4).

2.2.8 „RATE/CONC“ Key

**RATE
CONC** The „RATE/CONC“ key (7/10) is used to change the measured value presentation from RATE to CONC, and vice versa. It is effectual only in the SNIFF mode of the UL 500 dry.

RATE The measured value is displayed as a leak rate in the unit selected (8/5).

CONC The helium concentration is shown in ppm (8/4).

2.2.9 „PREC“ Key

PREC Pressing the „PREC“ key (7/12) influences the measurement range of the UL 500 dry during AUTORANGING, i.e. with this key the most sensitive measuring range is enabled or disabled.

The measuring range attainable by AUTORANGING normally ends at a leak rate of approx. $1 \cdot 10^{-9}$ mbar·l·s⁻¹. After pressing the „PREC“ key (7/12), maximum sensitivity is enabled for the detection of a leak rate of $5 \cdot 10^{-11}$ mbar·l·s⁻¹.

Note

If mostly test samples involving only small amounts of gas are to be analysed, PRECISION should be selected.

This must be acknowledged by actuating the „EXEC“ key (7/3). The request for the operator to do so appears in the alphanumeric display line (8/17), while the PREC

indicator (8/11) flashes.

This function can be cleared by operating the „CLR“ key (7/4).

The PRECISION function is indicated by the PREC display (8/11) staying lit.

Note

The PRECISION function is only possible in the MEASURE mode (7/17).

Leak rates under $1 \cdot 10^{-9}$ mbar·l·s⁻¹ cannot be measured until the test object's pressure is sufficiently low, which is reached in the course of evacuation. This is noticeable especially when large volumes are involved.

In the PRECISION operating modes the coupling valve is closed and the purge gas valve is opened. Thus a possibly present helium background in the auxiliary pump is reduced quickly. If a helium background builds up in the FINE operating mode, this background may then be reduced by switching to PRECISION during the measurement.

The function is deactivated by pressing the PREC key (7/12) again and acknowledging this via the EXEC key (7/3).

2.2.10 „MAX/ACT“ Key

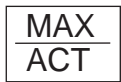

The „MAX/ACT“ key (7/11) can be used to select two functions:

- Retain the last maximum (MAX)
- Display the currently measured value (ACT)

Starting from the function just set, the function changes every time the key is pressed and this is visually represented on the MAX and ACT indicators (8/6).

The functions can only be selected in the MEASURE and DETECTING modes.

The key has no function in the INSPECT mode.

2.2.10.1 „MAXIMUM“ Function

Pressing the „MAX/ACT“ key (7/11) to obtain the function „Retain the last maximum“ has the result that only the maximum measured value which has occurred up to this point is shown in the digital display (8/3). The analog circular display (8/1) and the exponential scale (8/2) are not affected. They always show the currently measured value.

Pressing the „START/RESET MAX“ key (7/15) clears the max. value being displayed, and the currently measured value appears. The next measurement cycle begins, with the max. measured value again being stored on the digital display.

Pressing the STOP/VENT key (7/14) clears the MAXIMUM function.

2.2.10.2 „ACTUAL“ Function

With this type of display the currently measured value is always indicated on the digital display (8/3) and on the quasi-analog display (8/1) and (8/2).

2.2.11 „FAST/SLOW“ Key



The FAST/SLOW key (7/9) switches over the speed of the measured-value display.

FAST results in the display reacting quickly; with SLOW an unsettled measured-value reading is damped to a greater degree.

Note

The FAST function should be selected when wanting to localize leaks.

The function changes whenever this key is pressed. The function just selected is shown on the display (8/7).

2.2.12 Numeric Keypad

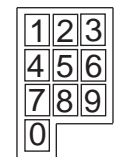

The numbers 0 to 9 (7/20) are employed to enter parameters required to operate the UL 500 dry.

2.2.13 „Decimal Point“ Key (.)

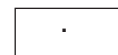

The decimal point key (7/19) is used in combination with the numeric keypad (7/20) to enter digits.

2.2.14 „EXP“ Key



The „EXP“ key (7/5) is used when entering numbers. The possible input point (cursor) immediately jumps to the first digit of the exponent when the key is pressed.

2.2.15 „PLUS/MINUS“ Key (+/-)

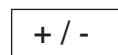

The „PLUS/MINUS“ key (+/-) (7/6) is used to change the sign when entering numbers.

2.2.16 „Arrows LEFT/RIGHT“ Key

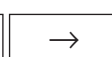
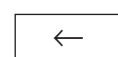

The keys Arrow pointing RIGHT (7/7) and Arrow pointing LEFT (7/8) have several functions:

- When entering numbers for the functions LIMIT LOW (7/22) and (8/16) and LIMIT HIGH (7/21) and (8/14), the

input position (cursor) is moved to the right or left by pressing the key (7/7) or (7/8), respectively. The position just selected flashes. The same function is employed in conjunction with inputs made via the alphanumeric display line (8/17).

- With LIMIT LOW and LIMIT HIGH (measurement range interval) active the display range can be shifted up or down by one decade. Thus it is possible to manually set the measurement range (manual ranging).
- Selection of an option (see Section 2.2.19).

2.2.17 „CLR“ Key

CLR The „CLR“ key (7/4) is used to cancel the last function entered.

The following functions are possible:

- Clear the command INSPECT/MEASURE.
- Clear the command SNIFF/VACUUM.
- Clear the command PRECISION.
- Clear the command CALIBRATE.
- Clear the command LIMIT LOW.
- Clear the command LIMIT HIGH.
- Clear the command OPTION.
- Clearing the display in case of a momentary error.
- Clearing the entry of the last entered programmed parameter.
- Termination of CAL.
- Termination of OPT AUTOTUNE.
- Termination of OPT ZERO.
- Termination of OPT CALEMV.

2.2.18 „LIMIT LOW/LIMIT HIGH“ Keys

LIMIT LOW **LIMIT HIGH** With the aid of the „LIMIT LOW“ (7/22) and „LIMIT HIGH“ (7/21) keys it is possible to enter a lower or higher limit for the measuring range.

LIMIT LOW affects only the possible measuring range of the UL 500 dry, while LIMIT HIGH also changes the representation on the analog circular display.

The LIMIT HIGH function depends on LIMIT LOW. LIMIT HIGH can only be operated if LIMIT LOW has already been activated.

Pressing one of the keys causes the corresponding digital display (8/14) or (8/16) to light up. The last limit value entered in the UL 500 dry appears with its first digit flashing. The following keys can be employed to change the numeric value:

Numeric

keypad: Changing the flashing digit by writing over it.

Point: Shifting the flashing input position to the decimal point.

Exponent: Shifting the flashing input position to the tens position of the exponent. This position can

only be occupied with 0 or 1. An input automatically moves the input position forward to the ones position.

+/-: Changing the sign of the exponent.

Arrow

left/right: Shifting the cursor through mantissa and exponent.

The following are also necessary to input the limit values:

EXECUTE: The „EXEC“ key terminates the input and accepts the number as the limit for measured values.

CLEAR: The „CLR“ key terminates the function of the limit for measured values. The number in the display is cleared.

2.2.18.1 Operation with Only „LIMIT LOW“ Activated

The numeric value entered defines the minimum leak rate which can be displayed. The AUTORANGE process is limited at the sensitivity associated with this leak rate. Normal measurement operation of the UL 500 dry and the display functions remain unchanged.

Pressing LIMIT LOW (7/22) and CLR (7/4) one after the other deactivates a low limit that has been set. The last numeric value entered remains stored and is shown again whenever LIMIT LOW is pressed.

2.2.18.2 Operation with „LIMIT LOW“ and „LIMIT HIGH“ Activated

The numeric values entered for the limits define the minimum and maximum leak rates which will be indicated.

The LIMIT HIGH function (7/21) can only be called if a lower measurement limit has already been entered with LIMIT LOW (7/22). Deactivating the low limit automatically deactivates the high limit as well. Deactivating the high limit alone initiates the transfer to the LIMIT LOW function (see Section 2.2.18.1).

Entering LIMIT HIGH changes the representation on the analog circular display (8/1). Two arrow symbols are displayed to indicate the possible representation range. The entire measuring range between the limits is now shown on this limited circular display.

The same also applies to the frequency range of the acoustic signal.

Note

The interval must always be equal to, or exceed one decade.

If the upper limit is not entered, a corresponding error message will be displayed.

Through LIMIT LOW the operation of the AUTORANGING is limited in the direction of higher sensitivities.

However, LIMIT HIGH has no effect on the switching in the direction of lower sensitivities at higher leak rates. If a measured value exceeds a set upper limit a segment above the limit value starts to flash and a warning signal can be heard.

2.2.18.3 Manual Ranging in Connection with set Upper and Lower limit

The keys „→“ „←“ can be used to shift the measurement range interval as set through LIMIT HIGH and LIMIT LOW by one decade up or down each time the arrow key is pressed. Thus it is possible to select the measurement range manually at a freely selectable resolution (minimum one decade).

2.2.19 „OPT“ Key

OPT With the aid of the „OPT“ key (7/2) it is possible to select or control optional functions of the UL 500 dry to which no key has been specifically assigned.

After pressing the „OPT“ key, the desired function can be selected with the support of a menu which indicates the designation of the option and the option number in the alphanumeric display line (8/17). On activating the OPT key, the last option selected is always displayed again, or after switching the unit on, option number 01 appears.

The least significant digit of the option number flashes and can be changed. An option can be selected by means of

- the two arrow keys. The arrow to the right increases the option number, and the arrow to the left decreases it. Like this, the operator can easily obtain overview of all option functions.
- the numeric keys. A digit is directly entered at the flashing least significant digit; if a second digit is entered, the this digit is shifted to the most significant digit. In this way, a specific option function can be directly selected.

Execution of a desired option function is initiated by pressing the „EXEC“ key (7/3). If the function produces a display in the alphanumeric display line, the display remains there until a key is actuated. The following applies:

- Pressing the „OPT“ key (7/2) causes the option menu to reappear.
- Pressing any other key produces a normal operational display of the UL 500 dry.

To cancel a request for an option, press the „CLR“ key (7/4). If an option number has not been assigned a function, the following display appears: OPT UNAVAILABLE.

The following optional functions are available in software

version 1.7:

01: Display P1 ON (OFF)

Switches on the continuous display of pressure P1 (inlet pressure) in the alphanumeric display line.

This display is switched off by reselecting OPT 01: DISPLAY P1 OFF.

Display of P1 causes display of P2 to be switched off.

02: Display P2 ON (OFF)

Switches on the continuous display of pressure P2 (foreline pressure) in the alphanumeric display line.

This display is switched off by reselecting OPT 02: Display of P2 causes display of P1 to be switched off.

03: DISPLAY DATE

Switches the alphanumeric display briefly (approx. 1s) to display the current date: The display indicates:

DATE dd.mm.yy
(d=day, m=month, y=year)

Note

This is only displayed provided the clock module has been built into the control pcb. Otherwise the following message is displayed:
NOT AVAILABLE

04: DISPLAY TIME

Switches the alphanumeric display briefly to display the current time: The display indicates:

TIME hh.mm.ss
(h=hour, m=minute, s=second)

Note

This is only displayed provided the clock module has been built into the control pcb. Otherwise the following message is displayed:

NOT AVAILABLE

05-09: OPT UNAVAILABLE

No functions assigned yet.

10: TRIGGER ON/OFF

Switches the functions of the optional trigger relay pcb. on and off. The leak rate values at which the relays are actuated are entered through the function LIMIT LOW and LIMIT HIGH. Moreover, the limits have to be set to active so that the relays can switch according to the set thresholds.

Note

This function can only be switched on provided the trigger relay pcb. has been built in. The presence of this option is sensed automatically when switching the UL 500 dry on. If the trigger relay option is not sensed and when selecting OPT 10 the display indicates:

10: NO TRIGGER

11: LK REC LOG ON (OFF)

Switches on the output of the leak rate at the recorder output in logarithmic form. When reselecting OPT 11 the output switches off.

The recorder output is assigned as follows:

Channel 1

(pin 5 of recorder socket)

Output of leak rate with 1.0 V to 10 V, 0.5 V per decade.

1.0 V corresponds to a leak rate of $1.0 \cdot 10^{-10}$ mbar·l·s⁻¹ and

1.5 V corresponds to a leak rate of $1.0 \cdot 10^{-9}$ mbar·l·s⁻¹ etc.

The associated ground wire is pin 3 of the recorder socket.

Channel 2

Channel 2 is not used.

The options OPT 11, OPT 12, OPT 13 and OPT 14 switch each other over.

12: LK REC LIN ON (OFF)

Switches on output of the leak rate at the recorder output in linear form. The output is switched off by reselecting OPT 12.

The recorder output is assigned as follows:

Channel 1

(pin 5 of recorder socket). Output of leak rate (mantissa) with 1.0 V to 9.9 V per decade.

The associated ground wire is pin 3 of the recorder socket.

Channel 2

(pin 1 of recorder socket). Output of leak rate exponent in steps of 0.5 V per decade.

1.0 V corresponds to the exponent -10; 1.5 V corresponds to -9, etc.

13: P1 - REC LOG ON (OFF)

Switches on output of pressure p1 (inlet pressure) at the recorder output. The output is switched off by reselecting OPT 13.

Output in logarithmic form:

Channel 1

(pin 5 of recorder socket) Output of pressure with 1.0 V to 10 V in 0.5 V per decade.

1.0 V corresponds to a pressure of $1.0 \cdot 10^{-3}$ mbar, 1.5 V corresponds to a pressure of $1.0 \cdot 10^{-2}$ mbar.

The associated ground wire is pin 3 of the recorder socket.

Channel 2

Channel 2 is not used.

The options OPT 11, OPT 12, OPT 13 and OPT 14 switch each other over.

14: P2 - REC LOG ON (OFF)

Switches on output of pressure p2 (foreline pressure) at the recorder output. The output is switched off by reselecting OPT 14.

Output in logarithmic form:

Channel 1

Channel 1 (pin 5 of recorder socket) Output of pressure with 1.0 V to 10 V in 0.5 V per decade.

1.0 V corresponds to a pressure of $1.0 \cdot 10^{-3}$ mbar, and 1.5 V corresponds to $1.0 \cdot 10^{-2}$ mbar.

The associated ground wire is pin 3 of the recorder socket.

Channel 2

Channel 2 is not used.

The options OPT 11, OPT 12, OPT 13 and OPT 14 switch each other over.

15: OPT UNAVAILABLE

No function assigned yet.

16: DISP TMP ROTOR

Displays once only the current frequency of the rotor of the turbomolecular pump (revolutions per second).

Display: TM-PUMP ROT: xxx RPS

For this measurement the turbomolecular pump is switched off briefly.

17: DISP TMP GENERAT

Displays once only the current generator frequency of the turbomolecular pump (revolutions per second).

Display: TM-PUMP GEN: xxx RPS

The nominal rotational speed depends on the equipment (see OPT 18).

18: DISP TMP NOMINAL

Displays the nominal frequency of the turbomolecular pump (revolutions per second), which varies within a certain range depending on the equipment.

Display: TM - PUMP NOM: xxx RPS

Also see OPT 17.

Note

The nominal value is also stated on the name plate of the pump.

19: DISP TESTLK TEMP

Displays once only the current temperature of the integrated calibrated leak (in °C).

Display: TESTLEAK TEPM: + xx C

20: DISP INT. TESTLK

Displays the leak rate of the integrated calibrated leak (mbar·l·s⁻¹) of the UL 500 dry.

Display: TESTLK: x.x E - yy ML/S

21: DISP SEL MASS NO

Displays the mass number to which the mass spectrometer is aligned.

Display: MASS: x u

Possible values for x are: 2, 3 or 4. Standard value is 4 (helium).

22: DISP VERS. NO STE

Displays the number of the software version of the control processor.

Display: STE: VERSION x.x

Note

- The first two digits of the software version number must be the same as for the communication processor (see OPT 23).
- To exchange the software see separate instructions „Exchanging the EPROMs in the helium leak detector ULTRATEST UL 500 dry“.

23: DISP VERS. NO KOM

Displays the number of the software version of the communication processor.

Display: KOM: VERSION x.x

Note

- The first two digits of the software version number must be the same as for the control processor (see OPT 22).
- To exchange the software see separate instructions „Exchanging the EPROMs in the helium leak detector ULTRATEST UL 500 dry“.

24: TUNE? EXEC/CLR

This option performs the alignment of the acceleration voltage for the mass spectrometer, in order to set the sensitivity to maximum for the programmed mass.

This process is performed in two stages.

Initially a coarse alignment is performed followed by fine tuning. This process can only be started from the STANDBY mode. Otherwise the following error message will occur:

NO TUNE IN DETECT

Note

The fine alignment for maximum is performed during each calibration process (with the exception of the first CAL after switching on; see also AUTOTUNE in Section 2.8.1).

25: ZERO? EXEC/CLR

This function performs the determination of the internal helium background in all measurement ranges. Thus the function ZERO expands the background resp. Zero determination in the FINE and PREC ranges each time the STOP cycle is run through.

The thus expanded values are taken into account

during all further measurements for checking the leak rate.

This can only be done starting from the STANDBY mode. Otherwise the following error message will be displayed:

NO ZERO IN DETECT

Note

The background is also determined each time the calibration process is run.

26: CAL EMV? EXEC/CLR

Determines the ratio between the output voltages of the high impedance amplifier for the 5 G Ω and 50 G Ω range as well as between the 50 G Ω and the 500 G Ω range.

By calculation of these factors it is possible to compensate resistance and thus gain errors between the measurement ranges during all further leak rate measurements.

The once determined values remain stored even in the case mains failure.

To perform the alignment a variable calibrated leak, range 1·10⁻⁵ mbar·l·s⁻¹ must be connected to the inlet (for example TL 4-6, Cat. No. 155 80).

The UL 500 dry must be set to operate in the DETECT mode by pressing START. Otherwise the following error message will be displayed:

NO CALEMV IN STBY

The alphanumeric display provides further information for the user. As the leak rate of the calibrated leak must be within a certain range, the following messages can occur:

SIGNAL TOO LOW

when the leak rate is too low

SIGNAL TOO HIGH

when the leak rate is too high.

The setting of the variable leak has to be changed until the message:

SIGNAL IN RANGE

is displayed. After this the setting of the calibrated leak may not be changed any more. The calibration process is then performed automatically.

The process can be terminated by pressing the „CLR“ key (7/4) and this is acknowledged briefly by the display of

CLEAR CALEMV

Note

As the resistance values change only slowly with time this alignment has to be carried out only very rarely. However, it must be carried out after exchanging the amplifier or the EPROMs of the control processor.

27: SETTING EXT V.24

This permits the setting of the parameters of the optional V.24 / RS 232 C interface. See Operating Instructions GA 10.292.

Note

- These settings can only be made with the interface pcb. built in. Its presence is automatically detected upon switching on the UL 500 dry.
- If the interface pcb. is not sensed and when selecting OPT 27 the following error message is displayed:

NO EXT-V.24

2.2.20 „HELP“ Key

HELP

The „HELP“ key (7/1) has no meaning during normal operation.

2.2.21 „EXEC“ Key

EXEC

The „EXEC“ key (7/3) is used to start or acknowledge functions which have been initiated via other keys.

Acknowledgements of messages of the UL 500 dry can be input via the „EXEC“ key (7/3).

2.2.22 Volume Control

The volume of the acoustic signal can be adjusted with the volume control (6/1).

Turning the volume control up increases the volume, turning it down decreases it.

2.2.23 Recorder Output and Remote Control Connection Socket

The pin-out of the recorder output and remote control connection socket is given in Fig. 11.

The measurement data are output in analogue form, depending on the operating mode selected via OPT 11 to OPT 14. The following voltages are output (recorder with an input resistance exceeding 2.5 k Ω):

1. Leak rate linear
Leak rate exponent
1.0 - 9.9 V per decade
(channel 1 / Pin 5)
0.5 V per decade
starting at 1 V at
 10^{-10} mbar·l·s $^{-1}$
(Channel 2 / Pin 1)
2. Leak rate logarithmic
0.5 V per decade
starting at 1 V at
 10^{-10} mbar·l·s $^{-1}$
(Channel 1 / Pin 5)
3. Inlet and forevacuum-
pressure logarithmic
0.5 V per decade
starting at 1 V at
 10^{-3} mbar
(Channel 1 / Pin 5)

The corresponding ground connection for channel 1 and channel 2 is the analogue ground pin 3.

Note

The output to the recorder is always in units of mbar·l·s $^{-1}$ resp. mbar. This is independent of the unit selected for the display.

The recorder output socket can additionally be used for the connection of a remote control unit through which is it possible to control the functions START and STOP / VENT.

Key to Fig. 11

Pin	Function
1	Channel 2 (exponent trigger voltage)
2	+15 V supply voltage for remote control
3	Analogue ground (for channel 1 and 2)
4	Connection remote control START / STOP
5	Channel 1 (measurement value lin. / log.)
6	Ground (screen)

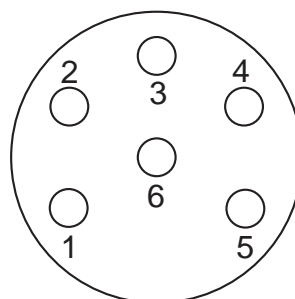

Fig. 11 Recorder output and remote control connection

Different voltages applied to the input (pin 4) provide the following functions.

- DC + 12.5 V to + 15 V: START
- DC 0 V to + 2.5 V for < 1.1 s : STOP
- DC 0 V to + 2.5 V for > 1.1 s : VENT

The + 15 V available at pin 2 can be used for the above purposes.

Caution



- The voltage is not short-circuit proof.
- The ground available at pin 6 (screen) must be used for the control inputs!

A suitable circuit is given in Fig. 12.

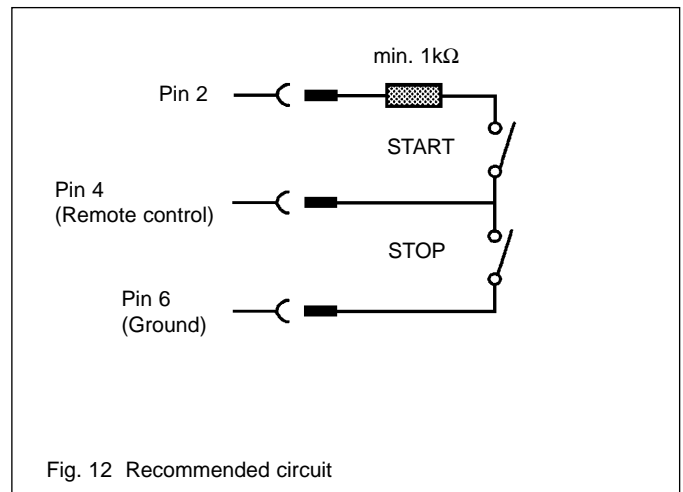

Fig. 12 Recommended circuit

2.2.24 Pin-out of the Multifunction Socket

The multifunction socket is only operative with built-in V.24 / RS 232 C option and / or trigger option. Details are given in the corresponding operating instructions for these options.

- V.24 / RS 232 C interface (Operating Instructions GA 10.292)
- Trigger relay pcb. (Operating Instructions GA 10.291)

The pin-out of the multifunction socket is given in Fig. 13.

2.2.25 Headset Output

See Fig. 6 for the connection of a headset. The loudspeaker is switched off when connecting a headset. The volume of the headset signal is adjusted via the volume control (see Section 2.2.22).

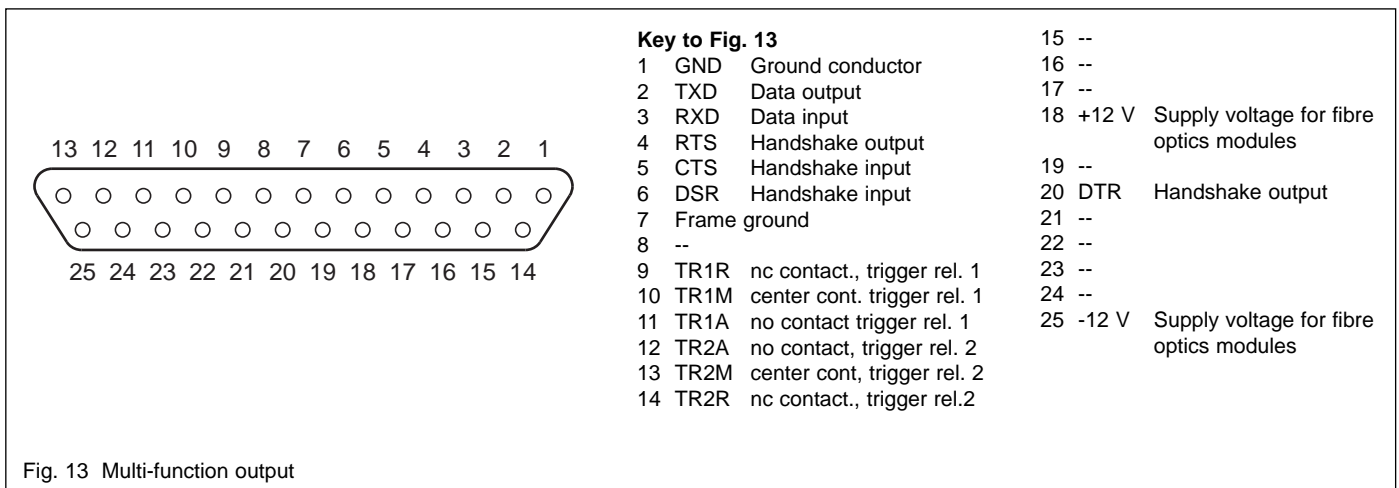

Fig. 13 Multi-function output

2.3 Description of Displays

Note

Refer to figures 7 and 8 in connection with the following descriptions.

The displays of the UL 500 dry serve, on the one hand, to indicate the measured values generated by the unit and, on the other, to provide information on the operating modes that have been set and to inform the operator as to the measurement sequence and requirements.

The displays are divided into three main groups:

- Measured-value displays as analog and digital displays,
 - Status displays,
 - General-purpose alphanumeric display.
- In addition there is available as a further „display“ function an
- Acoustic signal.

2.3.1 Analog Display

The primary function of the analog display of the UL 500 dry is to indicate the trend of the measured values for the leak rate quickly and clearly during leak detection.

The circular display (8/1) composed of 45 individual segments shows the measured leak rate in a quasi-analog form via a rotating illuminated indicator. Clockwise revolution means a rising leak rate, and counterclockwise revolution a falling one. It is therefore easily possible to localize the maximum leak rate by observing the direction in which the indicator is moving, which facilitates leak detection especially when great distances are involved with test objects.

In the equipment operating mode INSPECT the leak rate is shown only on the circular display (8/1). Depending on the operating mode selected for the display, there are two different types of representation on the circular display. The exponent associated with the measured value is displayed on the bar scale (8/2) beside it. Here one panel with the exponent number lights up in each case.

If no limit or only the low limit (see Section 2.2.18) has been activated to restrict the measuring range of the UL 500 dry, the circular display is in the normal operating mode.

This means that the leak rate measuring range is shown in decades on the circular display. One revolution of the indicator corresponds to one decade of the measured value from 1.0 to 9.9. The starting point of each decade at 1.0 is identified by a constantly illuminated line at the bottom of the circular display.

The display within each decade is in logarithmic form, thus permitting a more uniform representation when measured values are changing rapidly.

2.3.1.1 Analog Display in Conjunction with „LIMIT LOW / LIMIT HIGH“ Functions

The analog display range is limited by entering a low and a high limit value (see Section 2.2.18).

If both limit values of the measuring range are activated, the measuring interval thus defined is no longer indicated by several revolutions of the indicator. The entire interval is shown on a sector of the circular display limited by two arrow-like markers (8/15) which light up next to the limit-value indicators on the circular display.

The indicated interval always consists of entire measured value decades, with the measured value being indicated in logarithmic form within this interval.

2.3.2 Digital Display

In the MEASURE mode, the measured value for the leak rate is shown on the analog display and also quantitatively as a number.

The digital display (8/3) provides a two-digit representation of the mantissa of the measured value and a two-digit number for the exponent.

„u“ or „o“ may appear in addition at certain measured values before the displayed number.

Here the „u“ means that the real measured value is below the displayed one (underflow). This happens at the lowest levels of the measuring ranges and in case of running below an adjusted low limit (LIMIT LOW).

The „o“ means that the real measured value is above the displayed one (overflow), which occurs in case of exceeding an adjusted upper limit.

The display of the valid measurement unit (8/4) or (8/5) accompanies the digital display.

In the VACUUM mode, the leak rate units can be selected (see Section 2.2.2.1).

In the SNIFF mode, the display appears as leak rate or as concentration in ppm, depending on whether RATE or CONC was chosen. The representation of the numbers varies, depending on whether the ACTUAL or MAXIMUM function was selected (see Section 2.2.10).

2.3.2.1 Digital Display in Conjunction with „ACTUAL“ Function

The digital display always indicates the current measured value. This corresponds to the one shown on the analog display.

2.3.2.2 Digital Display in Conjunction with „MAXIMUM“ Function

The digital display shows the maximum leak rate value which has occurred during the measurement cycle initiated with the „START/RESET“ „MAX“ key (7/15). It is reset by again pressing „START/RESET“ „MAX“ or by pressing the „STOP/VENT“ key (7/14).

2.3.3 Limit Value Display (Low and High Limits)

Two displays with digits (8/14) and (8/16) are located below the circular display so that the high and low limits can be entered and checked. The left panel shows the value of the low limit, and the right panel that of the high limit. The representation of the panels corresponds to that of the digital display of measured values (8/3).

A two-digit mantissa of the measured value and a two-digit exponent with sign are displayed. The relationship to the analog display is explained in Section 2.3.1.

2.3.4 Status Displays

The status displays, which are of different colors, are used to indicate visually the functions that have been set.

Yellow displays: Display statuses
Orange displays: Equipment statuses related to the vacuum system
Red displays: Warnings

2.3.4.1 Description of Status Displays

FAST/SLOW

The FAST display (8/7) lights up when the measured-value display is set to react rapidly. The SLOW display (8/7) lights up when the measured-value display is set for greater damping.

MAX/ACT

The MAX display (8/6) lights up as a checkback signal when the function „Retain the last maximum“ has been set.

The ACT display (8/6) lights up as a checkback signal when the function „Display the currently measured value“ has been set.

BACKGRND

This display (8/12) lights up (red) when the measured value is not the absolute leak rate but when a helium background was suppressed by operating the „ZERO“ key (Section 2.2.6).

SNIFF/VAC

The SNIFF and VAC displays (8/10) respond as follows to a change in the operating mode:

- The display indicating the previous operating mode remains lit; the display for the newly selected mode flashes.
- If the „EXEC“ key is pressed, the display stops flashing and becomes steady, while the other is switched off.

STOP/VENT

The STOP and VENT displays (8/9) indicate the mode which the unit is in after the „STOP/VENT“ key (7/14) has been actuated for a short or long time (see Fig. 14).

In the STANDBY mode of the UL 500 dry, STOP lights up; in the VENTED mode, VENT always lights up as well.

PREC

The PREC display (8/11) identifies the expanded AUTORANGE.

Pressing the „PREC“ key (7/12) causes the PREC display (8/11) to start flashing. A request appears in the alphanumeric display line to acknowledge activation or deactivation of the PRECISION range by pressing the „EXEC“ key (7/3).

CAL

The CAL display (8/13) signals three statuses:

Deactivated:

- Always in the INSPECT mode.
- While the unit is warming up; during this phase, calibration is not feasible.
- In the MEASURE mode, with the unit warmed up and calibration already performed.

Flashing:

As the initial request to perform calibration when the warm-up phase is over (15 min approx.) and the unit has been or is being switched to the MEASURE mode. This is skipped if a calibration was performed during this time.

Steady light:

Further requests to perform calibration whenever the control processor considers this necessary owing to temperature-related drifting (± 5 °C) after prolonged periods of operation.

CAT 2

The ion source of the UL 500 dry is equipped with two cathodes. As soon as the cathode 1 normally used malfunctions, automatic switchover to cathode 2 occurs.

The red CAT 2 warning display (8/8) informs the operator that switchover has taken place, because failure of cathode 2 would then result in the failure of the entire instrument.

2.3.5 Alphanumeric Display

Any desired text can be shown in the alphanumeric display line (8/17) to support the operator in using the UL 500 dry. The following can be displayed:

-
- Specific measured values, e.g. inlet or foreline pressure.
 - Notes in the event of operator errors or illegal entries. The notes appear on the alphanumeric display for approx. 2 s; thereafter the normal display returns.
 - Requests for certain activities to be executed.
 - Error messages in the event of malfunctions, see Section 2.9. The error messages remain in the display until they are cleared by pressing the „EXEC“ key (7/3).

2.3.6 Acoustic Signal

The acoustic signal is used to indicate the leak rate. Its frequency is a measure of the leak rate value. The entire measuring range shown on the analog display is represented by a frequency range of approximately 60 Hz to 4 kHz.

The volume can be varied via a volume control (6/1).

2.4 Startup (First Pumpdown Cycle)

Step	Activity	Response	Displayed text
1	Blank off connecting flange (5/5) with a blank flange	--	
2	Set power switch (5/1) to ON	Start of automatic self test; Visual check of microprocessor modules; Visual check of status displays on display unit (Fig. 8) Activation of auxiliary pump and diaphragm pump Start of automatic runup of turbomolecular pumps (up to 4 min) Speed of the turbomolecular pump, run-up message for the TMP 35 and forevacuum pressure p2 are displayed in alternating fashion. Sensitivity test of the mass spectrometer for helium. Determination of electric offset-voltage and helium background to correct the measured values Status display STOP on display unit lights up	INFICON UL 500 dry V x.x PERFORMING SELFTEST ROM CHECK OK RAM TEST OK PERFORMING LCD-TEST SELFTEST: NO ERRORS TM-PUMP ACT: xxx RPS RUNNING UP TMP 35 P2: x.xE-yy mbar SENSITIVITY CHECK PERFORMING AUTOZERO STANDBY FOR (INSP)
3	Press „START“ key (7/15) briefly	Initiation of measurement procedure (pumpdown of dead volume at the inlet) Deactivation of status display STOP Display of leak rate on analog display	PREPARING (DETECT) DETECTING (INSP)
4	Press „STOP“ key (7/14) for more than 1.1 s	Initiation of STOP procedure Activation of status display STOP Display of detection limit Initiation of venting procedure Vent valve opens after approx. 1.1 s Activation of status display VENT	PREPARING (STOP) STANDBY FOR (INSP) PREPARING (VENT) STANDBY FOR (INSP)
5	Open connecting flange (5/5)	--	
6	Connect test object	--	
7	Press „START“ key (7/15) briefly	Initiation of measurement procedure (pumpdown of the test objekt) Deactivation of status displays STOP and VENT	PREPARING (DETECT) DETECTING (INSP)
8	Spray test object with helium	Display of leak rate on analog display	
9	Press „STOP/VENT“ key for more than 1.1 s	Initiation of STOP procedure Activation of status display STOP Display of detection limit Initiation of venting procedure Vent valve opens after approx. 1.1 s Activation of status display VENT	PREPARING (STOP) STANDBY FOR (INSP) PREPARING (VENT) STANDBY FOR (INSP)
10	Disconnect test object	--	

2.5 Operating Modes

The standard UL 500 dry is equipped for two basic operating modes: vacuum mode (VAC) and sniffing mode (SNIFF).

In each of these modes, the UL 500 dry can operate in the inspection mode (INSP) or measurement mode (MEAS). See Fig. 14.

2.5.1 Vacuum Mode (VAC)

In the VAC mode, a test object is flanged to the inlet of the UL 500 dry and evacuated by pressing the „START“ key. The pressure in the test object may vary between 100 mbar and less than 10^{-3} mbar. When the evacuated test object is sprayed with helium, helium can enter the test object through any existing leak, owing to the pressure difference. The helium reaches the mass spectrometer where the gas molecules are ionized and detected.

Note

If the ambient air is found to be enriched with helium, carry out one of the following measures:
 - Connect hoses to the exhaust lines and the purge gas

connection at the rear of the UL 500 dry (9/6), (9/7) and (9/8) and lead them to helium-free air.

2.5.1.1 Local Leak Detection in the Vacuum Mode

For local leak detection, the test object (15/2) connected to the UL 500 dry must be sprayed with helium at the points where leaks are suspected. If possible, use a spray gun with a fine nozzle (15/4).

In order to detect very small leaks next to leaks already discovered on the test object, the latter must be sealed by coating them with alcohol or by preventing the access of helium by screening the leak. See Fig. 15.

In the case of systems with pumps of their own, check the sensitivity of the entire system with a calibrated leak. Because of the additional pumps the UL 500 dry measures only a partial flow of the total leak rate, i.e. the detection limit will now be above $2 \cdot 10^{-10}$ mbar·l·s⁻¹.

A calibration may be performed with an external calibrated leak by pressing the „CAL“ key even in the case of high partial flow ratios (Section 2.7.1.2).

The response time is also determined with an external calibrated leak. To do this, a calibrated leak is connected to the test object at the point furthest away from the test

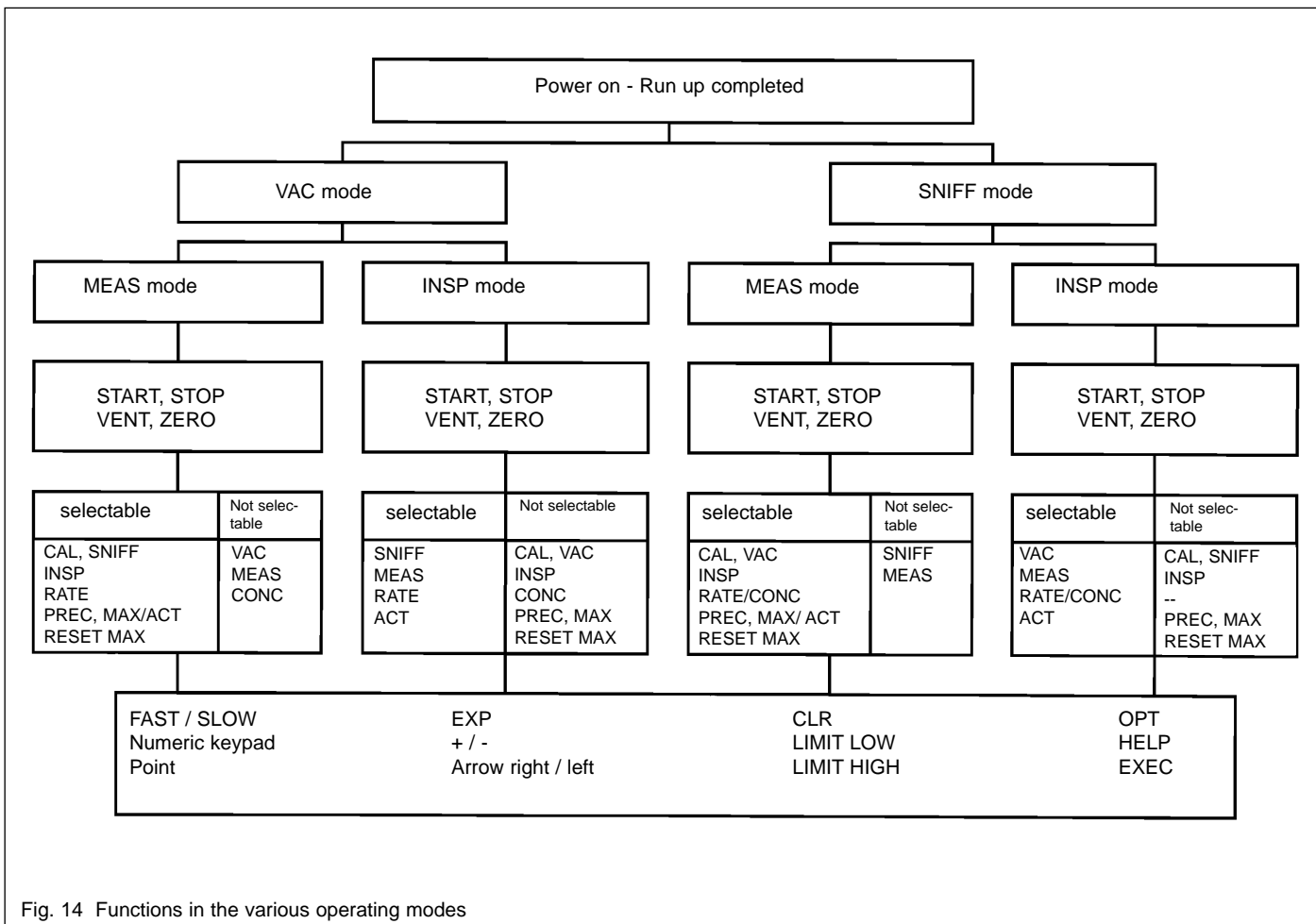
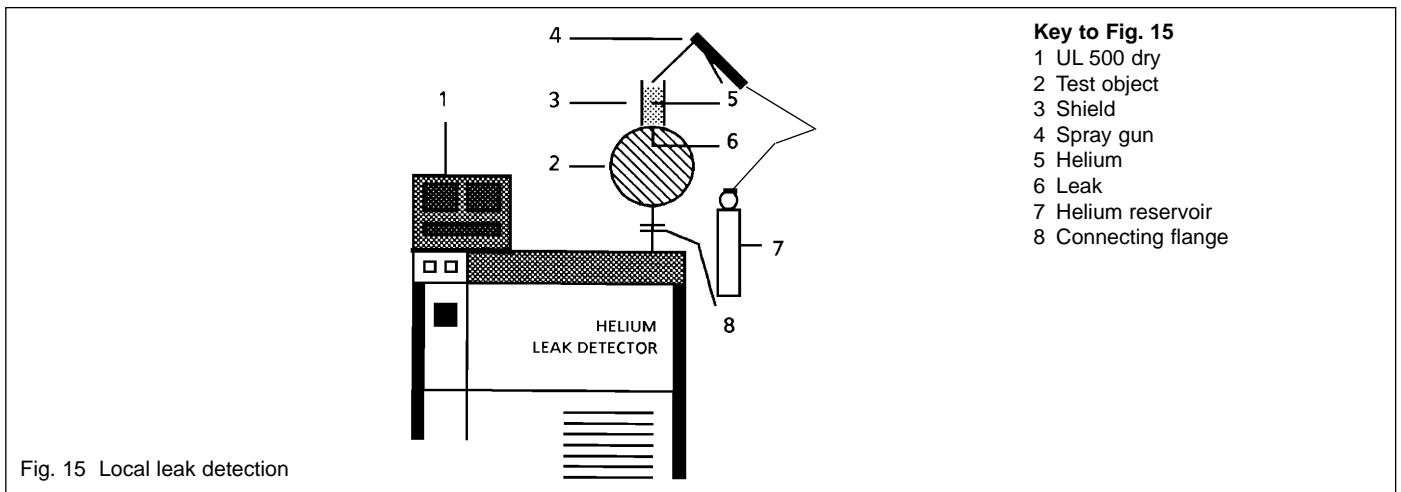

Fig. 14 Functions in the various operating modes



connection. The leak rate indicated by the UL 500 dry is the leak rate of the calibrated leak. The calibrated leak is closed, and simultaneously the time is measured until the leak rate indicated by the UL 500 dry has dropped to about 37 % of the original value. The time thus recorded is the response time.

During quantitative local leak detection helium has to be sprayed onto the leak at least as long as the response time. Otherwise the displayed value may lie considerably below the actual leak rate.

2.5.1.2 Integral Leak Detection in the Vacuum Mode

For integral leak detection, the test object (16/2) is enclosed in a hood (16/3), e.g. a PVC bag, filled with a known helium concentration (16/4). If possible, the connecting flange (16/6) should not be surrounded by the hood, since helium might diffuse through the connecting gasket and cause a background.

The test time should be kept as short as possible for integral leak detection. If it is too long, the test object may become contaminated (see Fig. 16).

Note

In the case of very large leaks (for example by sudden damage to the test sample) there is a risk of helium contamination in the foreline pumps, leading to an erratic background signal thus preventing sensitive measurements. In such a case the following error message is displayed:

BACKGROUND TOO HIGH
OPEN GASBALLAST

Measures:

- Set LIMIT LOW to a higher value so that the background is no longer displayed (provided only large leaks are of interest).
- if possible switch to PRECISION; in this mode the purge gas valve is opened during the measurement so that the helium background is reduced.
- if the pressure is too high to switch to PRECISION, switch to STANDBY for about 20 seconds. The purge gas valve is then also opened and the helium background is reduced.

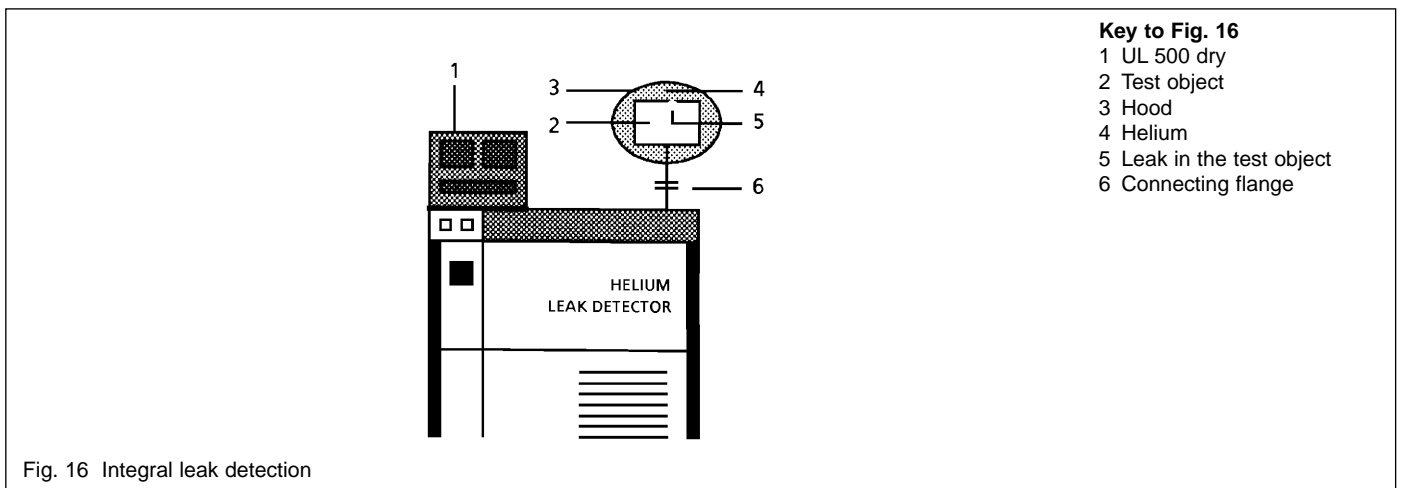

2.5.2 „SNIFF“ Mode

In this basic operating mode, leak detection on a test object filled with helium at overpressure is possible. For this purpose, a standard or QUICKTEST sniffer is connected to the inlet of the UL 500 dry.

If there is a leak in the helium-filled test object, helium is forced out by the overpressure and can be sucked in by the UL 500 dry via the sniffer.

Helium thus reaches the mass spectrometer, where the gas molecules are ionized and detected. In the SNIFF mode, quantitative determination of the leak rate is also possible.

The main difference between the SNIFF and VAC modes are the calibration possibilities of the former.

2.5.2.1 Local Leak Detection in the „SNIFF“ Mode

For local leak detection in the SNIFF mode, a test object filled with helium is scanned locally with the sniffer probe to find any leaks.

The actual leak rate of the test object can only be displayed after calibration under defined sniffing conditions.

The calibration factor for the UL 500 dry can be determined through the CAL function in the SNIFF (MEAS) mode.

To do this press the following keys:

„SNIFF“, „MEAS“, „RATE“, „FAST“

See Section 2.7 for details on this calibration.

The calibration only applies for the position of the sniffer tip used for the calibration. Correction of leak rate to standard leak rates (100 % He, 1 bar to 0 bar) see Section 2.5.2.3.

Preparations for determining the actual leak rate:

Press the following keys :

„SNIFF“, „MEAS“, „RATE“, „MAX“ and „FAST“.

The calibration factor is calculated on the UL 500 dry by the calibration function in the SNIFF mode (MEAS).

Determination of the actual leak of a test object:

The test object must be scanned with the same sniffing speed and the same sniffing distance as was used for the calibration procedure.

With calibration completed, the actual leak rate is then displayed on the UL 500 dry.

Note

If the test object is not filled with 100 % helium, the actual leak rate obtained on the test object (Q_{LEAK}) must be corrected using a helium concentration factor in order to obtain the true leak rate.

2.5.2.2 Integral Leak Detection in the „SNIFF“ Mode

For integral leak detection in the SNIFF mode, the helium-filled test object is placed in a sealed hood. If there are one or more leaks, helium gradually flows into the hood where it enriches slowly. To measure the rise in the helium concentration in the hood, the sniffer tip is introduced into the hood at the end of the waiting period.

After appropriate concentration calibration (see Section 2.7) for example with air helium, the UL 500 dry directly displays the helium concentration.

Preparations for determining the actual leak rate:

Press the following keys on the UL 500 dry:

„SNIFF“, „MEAS“, „CONC“, „ACT“ and „SLOW“.

To determine the actual leak rate (Q_{LEAK}), the air-helium concentration (Q_L) is first measured with the UL 500 dry and set to zero with the aid of the „ZERO“ key.

Then, using a thick PVC foil, a sealed volume is established around the point to be tested, and the actual hood volume is established.

Note

An error in estimating the hood volume has a linear effect on the leak rate determination, i.e. percentage error in volume = percentage error in leak rate.

After an adequate waiting period (Δt), the sniffer is introduced into the hood and the finally displayed value (ΔC_{HE}) is recorded.

Calculation of the actual leak rate (Q_{LEAK}):

Data needed:

V_H hood volume in liters

P_O atmospheric pressure in mbar

t waiting time in seconds

ΔC_{HE} change in helium concentration in hood

Note

The displayed change in concentration is only correct if the initial value (air-helium concentration) was set to zero with the ZERO key.

$$Q_{LEAK} = \frac{V_H \cdot P_O \cdot C_{HE}}{\Delta t} \quad [1]$$

Note

The determined leak rate of the test object is only valid for the parameters prevailing during the test. Other leak rates are obtained if the pressure differential, type of gas, temperature or liquid charge changes. If the test object is not filled with a 100 % helium concentration, the leak rate must also be corrected with a helium concentration factor.

2.5.2.3 Calculation of Standard Leak Rate as a Function of Pressure Differential

The leak rate obtained must be converted to arrive at the standard leak rate Q_0^N .

This is the helium flow in $\text{mbar}\cdot\text{l}\cdot\text{s}^{-1}$, that passes through the leak in the case of 100 % helium in front of the leak and a pressure differential of 1 bar vs. 0 bar.

If the test sample is not filled with 100 % helium but with x % helium the following correction has to be made:

$$Q_{\text{corr}} = (Q_{\text{meas}} / x) \cdot 100$$

With Q_{corr} it is then possible to carry out the following correction for higher pressures in the test sample. In the following Q_{corr} is abbreviated by Q ; the standard leak rate to be determined (100 % He, 1 bar \rightarrow 0 bar) is termed Q_0 .

The calculation given below permits conversion of the measured leak rate (at the true pressure differential) into the leak rate at 1 bar helium pressure in front of the leak and 0 bar pressure behind it. This leak rate is termed Q_0 . In the laminar flow region, the leak rate is a square function of the pressure differential.

$$Q (P_1 \rightarrow P_2) = Q_0 (P_1^2 - P_2^2) \quad [1]$$

- Q measured leak rate (Q_{corr})
- P_1 absolute pressure in test object
- P_2 atmospheric pressure = 1 bar
- Q_0 leak rate at 1 bar helium vs. 0 bar

Rearranging Eq. (1) results in:

$$Q_0 = \frac{Q_{\text{Corr}}}{P_1^2 - P_2^2} \quad [2]$$

and with $p_2 = 1$ bar

$$Q_0 = \frac{Q_{\text{Corr}}}{P_1^2 - 1} \quad (P_1 \text{ in bar}) \quad [3]$$

2.5.3 „INSPECT“ Mode

The INSPECT mode can be selected in both the VAC and SNIFF modes.

In this mode, the analog display permits precise localization of the leak; the digital leak rate display is deactivated.

Note

It is not necessary to calibrate the UL 500 dry. (For quantitative leak detection, the MEASURE mode has to be selected.)

2.5.4 „MEASURE“ Mode

The MEASURE mode can be performed in both the VAC and SNIFF modes.

The operator can activate the integrated CAL function of the UL 500 dry at any time. Then leaks can be quantitatively determined between $10 \text{ mbar}\cdot\text{l}\cdot\text{s}^{-1}$ and $2\cdot 10^{-10} \text{ mbar}\cdot\text{l}\cdot\text{s}^{-1}$ in the VAC mode (in the SNIFF mode, this is dependent on the sniffing parameters, up to $10^{-6} \text{ mbar}\cdot\text{l}\cdot\text{s}^{-1}$).

It is possible to display the maximum value on the digital display in order to read the precise leak rates during local leak detection (see 2.2.10.1 and 2.2.10.2.).

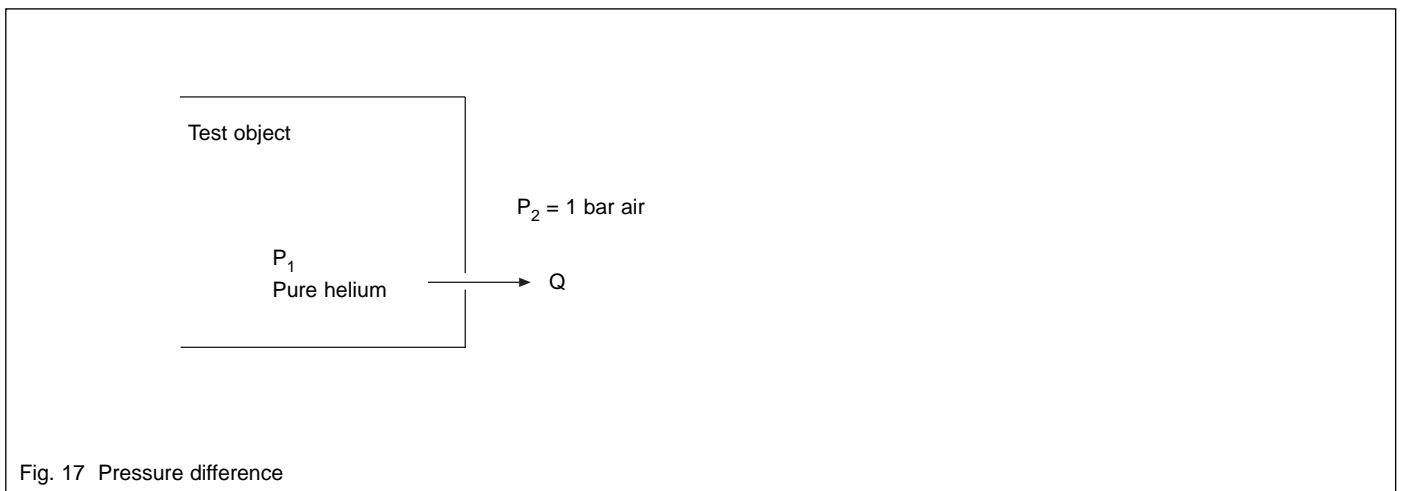

Fig. 17 Pressure difference

2.6 Shutdown

To put the UL 500 dry out of operation, set the main switch (5/1) to „OFF“. No further action is necessary.

The operating mode of the UL 500 dry is stored in a battery backed-up memory when switching off, so that the same operating mode is set up automatically when switching on again (see also Section 2.2.1).

2.7 Calibration

2.7.1 Calibration in the Vacuum Mode

In the vacuum mode (VAC), the UL 500 dry can be calibrated with its integrated calibrated leak or with an external calibrated leak mounted directly at the test connection.

Note

If the UL 500 dry is connected to a vacuum system, external calibration must be performed with a calibrated leak mounted at the furthest point of the vacuum system.

2.7.1.1 Calibration with Internal Calibrated Leak

For leak testing of components a calibration with the integrated helium test leak is normally initiated by pressing the „CAL“ key (see Section 2.2.7). It can only be performed in the STANDBY mode. Then the UL 500 dry automatically controls the subsequent operations.

These are:

- Measurement of Zero,
- Measurement of actual value (opening and closing of the calibrated leak),
- Calculation of calibration factor.

Initiation of internal calibration:

- Press „STOP“ key
- Press „CAL“ key
- Press „EXEC“ key

Termination of internal calibration:

- Press „CLR“ key.

2.7.1.2 Calibration with External Calibrated Leak

In order to take proper account of the influence of the test object's pressure and possible pressure conditions in partial-flow operation, calibration with an external calibrated leak is required. The use of calibrated leaks is permissible which produce a reading between $8 \cdot 10^{-9}$ mbar·l·s⁻¹ and $9.9 \cdot 10^{-4}$ mbar·l·s⁻¹.

Note

If the volume flow rate of the vacuum system is high, the

real leak rates of the calibrated leaks must be considerably higher in order to produce a useful reading.

For an external calibration it is caution that the UL 500 dry is in the DETECT mode (see also „CAL“ key in Section 2.2.7).

The external calibration process is prepared by connection of an external calibrated leak to the system or the test samples.

Starting the process:

- Press „START“ and after pumpdown wait for the „DETECTING“ message
- Press „CAL“ key (7/16)
- Press „EXEC“ key (7/3).

The running process may be terminated by pressing the „CLR“ key (7/4).

After starting, messages appear on the alphanumeric display line (8/17) informing the operator of the sequence and requesting him to perform further operations.

CAL EXT. ? : EXEC / CLR

Press „EXEC“ key (7/3).

EXT. TLK ? = x.xE-xx

Enter leak rate of the calibrated leak.

Note

When running an external calibration using the unit Pa·m³·s⁻¹ the value of the calibrated leak **must** be entered in mbar·l·s⁻¹ as otherwise the calibration results calculated will be incorrect!

Press „EXEC“ key (7/3).

OPEN TESTLEAK ! EXEC

Open calibrated leak, acknowledge by pressing „EXEC“.

SIGNAL STABLE ? EXEC

Wait until the signal is stable, then press „EXEC“ key (7/3).

CLOSE TESTLEAK ! EXEC

Close calibrated leak, then press „EXEC“ key.

SIGNAL STABLE ? EXEC

Wait until the signal is stable, then press „EXEC“ key (7/3).

The UL 500 dry automatically determines the calibration factor for the leak rate measurement, followed by the message:

CALIBRATION FINISHED

The instrument is now ready for further measurements. The „CLR“ key can be used to erase this message.

Note

In order to determine the calibration factor a minimum

difference in the leak rate signal is required between opened and closed calibrated leak. If this difference is too small the following error message occurs:

ER : CAL - DIFFERENCE <<

In such a case select PREC and repeat the calibration!

2.7.2 Calibration in the „SNIFF“ Mode

In the SNIFF mode the UL 500 dry can only be calibrated externally. However, it is possible to perform this calibration for concentrations (ppm) and leak rates ($\text{mbar}\cdot\text{l}\cdot\text{s}^{-1}$).

For the calibration the UL 500 dry must be in the DETECT mode with the sniffer connected (Press „START“ key).

Note

In order to obtain the highest possible sensitivity the UL 500 dry should be set to the PREC mode.

2.7.2.1 Calibration with a Known Helium Concentration

Range 5 ppm to $9.9\cdot 10^3$ ppm.

In the simplest case the calibration is carried out with air helium (5 ppm). This air must not be contaminated by helium, i.e. helium must not have been sprayed in the vicinity.

If considerably higher concentrations are to be measured later on it is advisable to produce a corresponding known helium concentration in a bag.

Special bags with an aluminium coating are used for this purpose. Initially the bag is filled with pure inert gas (e.g. Ar, N₂) and helium is filled in using a syringe.

Both the amount of inert gas and helium have to be known precisely. It is only then possible to calculate the concentration.

Switch the UL 500 dry to „CONC“ with the key „RATE/CONC“. The display is now in ppm.

Starting the calibration:

- Press „START“ key; after pumpdown wait for the message „DETECTING“.
- Press „CAL“ key.
- Press „EXEC“ key.

The running process may be terminated by pressing the „CLR“ key.

After starting, messages appear on the alphanumeric display line (8/17) informing the operator of the sequence and requesting him to perform further operations.

CAL EXT. ? : EXEC / CLR

Press „EXEC“ (7/3) key.

CONC [PPM] ? = x.xE-xx

Enter the test concentration (e.g. 5 ppm = 5.0E-00).

Press „EXEC“ (7/3) key.

SNIFF CONC ! EXEC

Hold the sniffer tip into the gas with the known helium concentration (e.g.air), then press „EXEC“ (7/3) key.

SIGNAL STABLE ? EXEC

Wait until the signal is stable, then press „EXEC“ key (7/3).

The UL 500 dry automatically determines the calibration factor for the concentration measurements based on the determined concentration and the last available value of the internal Zero.

This is followed by the message:

CALIBRATION FINISHED

The instrument is now ready for further measurements. (The „CLR“ key can be used to erase this message.)

Note

In order to determine the calibration factor a minimum difference between signal and Zero is required. If this difference is too small the following error message occurs:

ER : CAL - DIFFERENCE <<

In such a case select PREC and repeat the calibration.

2.7.2.2 Calibration of Helium Leak Rate

Range $1\cdot 10^{-6}$ to $9.9\cdot 10^{-4}$ $\text{mbar}\cdot\text{l}\cdot\text{s}^{-1}$.

The calibration of the helium leak rate requires a sniffer calibrated leak (e.g. Cat. No. 155 88, TL 4-6) (a sample of a faulty component filled with helium may also be used for comparative purposes!).

After having entered the set point leak rate and unscrewing the blocking valve at the leak (the leak is then directly accessible) proceed as follows:

Switch the UL 500 dry to „RATE“ with the key „RATE/CONC“.

The displayed values will then be in the unit whichever was preselected.

Starting the calibration:

- Press „START“ key; after pumpdown wait for the message „DETECTING“ .
- Press „CAL“ key.
- Press „EXEC“ key.

The running process may be terminated by pressing the „CLR“ key .

After starting, messages appear on the alphanumeric display line (8/17) informing the operator of the sequence and requesting him to perform further operations.

CAL EXT. ? : EXEC / CLR

Press „EXEC“ (7/3) key.

EXT. TLK ? = x.xE-xx

Enter the leak rate of the calibrated leak and then press the „EXEC“ key.

SMELL TESTLEAK ! EXEC

Hold the sniffer tip at a defined distance from the calibrated leak and then press the „EXEC“ key (7/3).

SIGNAL STABLE ? EXEC

Wait until the signal is stable, then press „EXEC“ key (7/3).

SMELL AIR ! EXEC

Hold the sniffer tip in uncontaminated air, then press „EXEC“ key (7/3).

SIGNAL STABLE ? EXEC

Wait until the signal is stable, then press „EXEC“ key (7/3).

The UL 500 dry automatically determines the calibration factor for the leak rate measurement, followed by:

CALIBRATION FINISHED

The instrument is now ready for further measurements. The „CLR“ key can be used to erase this message.

Note

In order to determine the calibration factor a minimum difference in the signal between calibrated leak and air is required. If too small the following error message occurs:

ER : CAL - DIFFERENCE <<

In such a case select PREC and repeat the calibration.

2.8 Automatic Functions

The UL 500 dry has three automatically executed functions which ensure that the displayed measured values are correct.

2.8.1 AUTOTUNE

This function automatically aligns the mass spectrometer to the maximum leak rate display. For this purpose, the UL 500 dry uses the internal, helium-filled calibrated leak. The control processor varies the accelerating voltage of the ions in the selected mass range until a maximum ion current is registered on the ion collector.

This is done in two steps: Coarse and fine alignment (see OPT 24).

A fine alignment is performed automatically before each calibration.

2.8.2 AUTOZERO

This function is employed to define the unit's internal Zero for the leak rate signal in order to prevent the display of the internal helium background and offset voltages as measured values.

This function is carried out automatically each time the UL 500 dry is switched from DETECT to STANDBY by pressing the „STOP“ key. (See also the function of the key „STOP/VENT“.)

The value of the helium signal is measured in the ranges FINE 3 and PREC and the measured values are stored as „Zero references“. Each further measured leak rate value is corrected by the applicable offset value.

If negative leak rate values are produced through this correction all stored offset values are changed so that the smallest value will be Zero. Thus the values are automatically adapted to a gradually decreasing background.

If the helium background increases this cannot be automatically sensed. This increase is only considered after a transition from DETECT to STANDBY.

2.8.3 AUTORANGE

The UL 500 dry possesses an automatic measuring range selection, which covers the entire leak rate range from 10 to $2 \cdot 10^{-10}$ mbar·l·s⁻¹. Not only the leak rate signal but also the testobject and massspectrometer pressure are used for control purposes. The measuring ranges are switched over as follows:

- Main switchover to the main ranges GROSS, FINE and PREC by means of valve switchover.

GROSS Display limit $1 \cdot 10^{-6}$ mbar·l·s⁻¹
 if $100 \text{ mbar} > p_1 > 0.1 \text{ mbar}$
 valve position: V_H, V_B open

FINE Display limit $1 \cdot 10^{-9}$ mbar·l·s⁻¹
 if $p_2 > 2 \cdot 10^{-2}$ mbar
 or not PREC
 valve position: V_E, V_K open

PREC Display limit $2 \cdot 10^{-11}$ mbar·l·s⁻¹
 Valve: V_E open

- Fine range switching within the main ranges by switching of the resistors within the amplifier.

Note

- If there is a lot of gas and thus a high pressure p_1 at the inlet flange it may be impossible to switch to a higher sensitivity despite of a low helium signal. This can occur for the transition GROSS to FINE when p_1 exceeds 0.1 mbar and for the transition FINE to PREC when p_2 exceeds $4 \cdot 10^{-2}$ mbar.

- The AUTORANGE process can be limited by setting of LIMIT LOW and LIMIT HIGH. This permits manual ranging by the user. See Section 2.2.18.3.

3 Maintenance

3.1 Scroll Pump and Diaphragm Pump Maintenance

3.1.1 Diaphragm Pump

Generally the diaphragm pump will not require any maintenance. However, as a preventive measure the diaphragms and valves should be exchanged after about 6,000 operating hours (for this refer to the Operating Instructions for this pump).

3.1.2 Scroll Pump

It is recommended to exchange after 6,000 operating hours the gaskets at the screw and to renew the lubrication. After 12,000 operating hours the bearings and the remaining gaskets must be exchanged (for this refer to the Operating Instructions for this pump).

3.2 Exchanging the Fluorescent Tube Behind the Display

Exchanging the fluorescent tube (life 1000 to 2000 operating hours) behind the display should be left to the INFICON service as the display can easily be damaged in the process. The exchange must be carried out close-

ly following the service instructions (SA 10.204).

3.3 Changing the Fuses on the Power Distribution (LV) Front Panel

The fuses are located on the lefthand plug-in (LV assembly), behind the upper front panel (see Fig. 18).

The fuses are assigned as follows:

S4	T 4 A	Pump PV
S5	T 1 A	Compressor motor
S6	T 2 A	Ventilator
S7	T 1 A	QUICKTEST connection (Plug ST 40)
S8	T 2 A	Spare
S9	T 1 A	Spare
S10	T 2 A	VP 2 (+24 V) valves

Exchanging the fuses:

Warning

Before exchanging the fuses, switch off the unit and disconnect it from the mains.

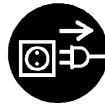

Flip the upper front panel (18/4) down so that it is placed horizontally.

Use a screwdriver to loosen the required fuse cap by turning it to the right (Bajonett lock).

Key to Fig. 18

- 1 QUICKTEST connection socket (220 V)
- 2 Reset pushbutton for error messages
- 3 Seven segment error message display
- 4 Front panel
- 5 Power distribution assembly (LV)

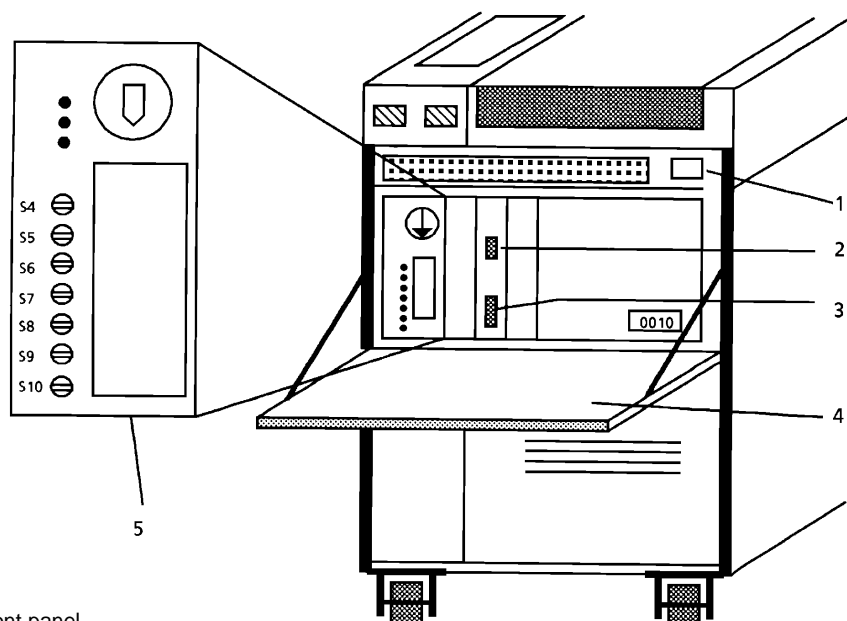

Fig. 18 Fuses on the power distribution (LV) front panel

Take out the fuse cap together with the fuse.

Exchange the fuse.

Reassemble in the reverse order.

Note

The main fuses of the UL 500 dry are located on the LV assembly board and can only be changed by removing the board. They may only be exchanged by suitably qualified electricians!

3.4 Exchanging the Filter Mat

The filter mat (19/4) is located inside the rear panel and has to be exchanged when applicable. (It is available as an accessory, Ref. No. 200 62 006.)

Use a screwdriver to turn the quick locks (19/2) by 90 °, thus loosening them.

Carefully flip the upper part of the rear panel backwards.

Pull the plug (19/6) for the fans located on the middle bar.

Carefully pull the rear panel (19/1) up and backwards from the fixing bolts and push slightly to the back.

Note

When pushing back the rear panel take care that the connected mains cable and any possibly connected hoses are not caught by the cut-out.

Remove both clips (19/3) from the holding rods (19/5).

Detach the filter mat (19/4) and exchange it.

After having exchanged the filter mat slightly compress the clips so as to insert them between the holding rails.

Then reassemble in the reverse order.

3.5 Draining Condensate from the Compressor Buffer Vessel

Depending on the operating conditions condensated water may collect in the compressor buffer vessel (20/3) of the compressor assembly (20/1).

The buffer vessel has to be drained when applicable.

Use a screwdriver to turn the quick locks (19/2) by 90 °, thus loosening them.

Carefully flip the upper part of the rear panel backwards.

To drain the buffer vessel (20/3) it has to be unscrewed from the pressure distribution block (20/2).

A 17 mm spanner is required for this purpose.

Note

A gasket is placed on the thread of the buffer vessel, which may drop off when draining the buffer vessel. A lost gasket can be replaced by a new gasket available under Ref. No. 239 73 136.

Next drain the buffer vessel with the opening pointing downwards.

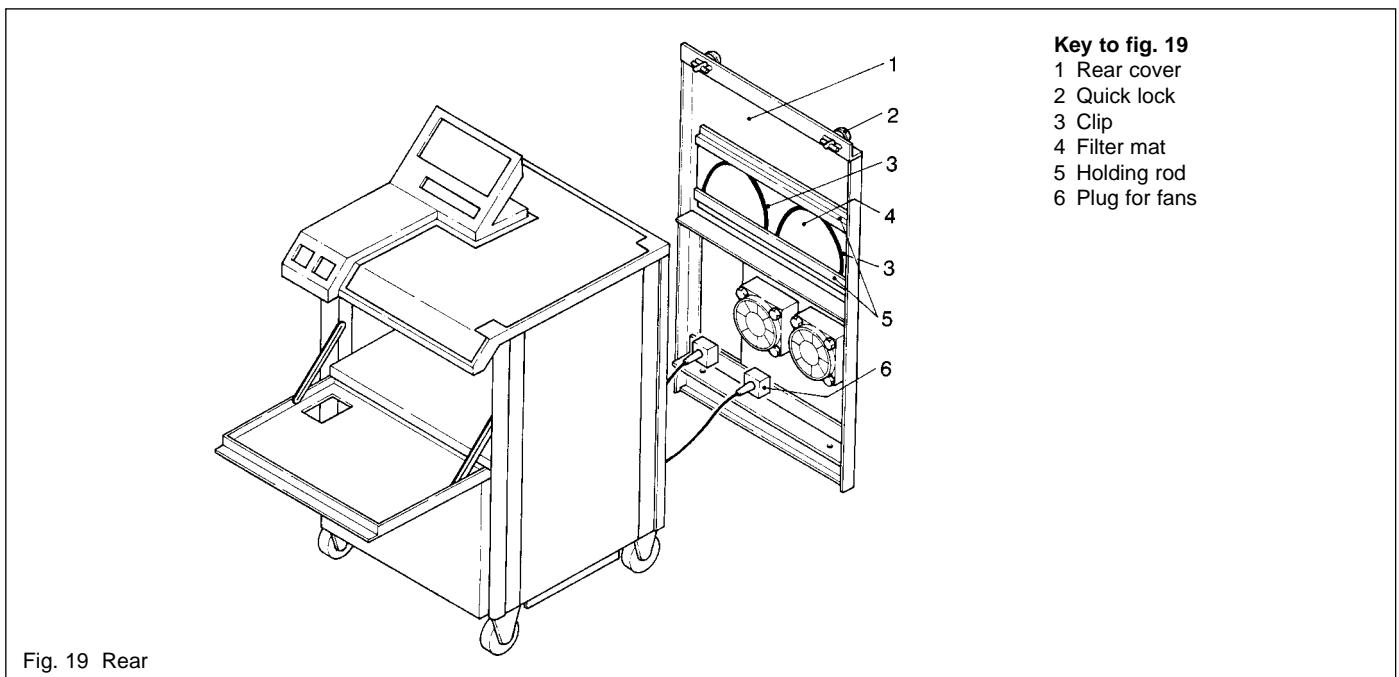

Fig. 19 Rear

Key to Fig. 20

- 1 Compressor assembly
- 2 Pressure distribution block
- 3 Buffer vessel

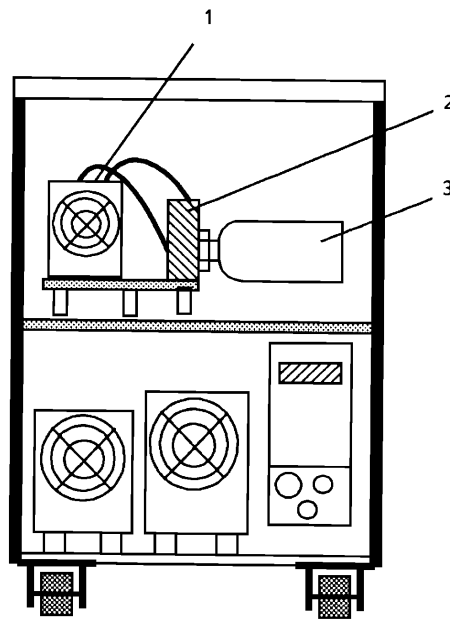

Fig. 20 Rear (compressor unit)

Before reassembly check the seating of the gasket on the buffer vessel.

Then reassemble in the reverse order.

3.6 INFICON Service

If you send an appliance to INFICON indicate whether the appliance is free of substances damaging to health or whether it is contaminated. If it is contaminated also indicate the nature of hazard. To do so, you must use a preprinted form which we shall send to you upon request.

A copy of this form is printed at the end of the Operating Instructions: „Declaration of Contamination of Vacuum Equipment and Components“.

Either fasten this form at the appliance or simply enclose it with the appliance.

This declaration of contamination is necessary to comply with legal requirements and to protect our staff.

INFICON must return any appliance without a declaration of contamination to the sender's address.

ANNEX 1

Parameter entry mode (PARA MODE)

For proper operation the UL 500 dry requires some parameters, which are partly specific to the unit and some which can be changed by switching to other operating modes. The parameters are stored in a battery backed up memory and are not lost when switching off the mains. Should none-the-less the data be lost, the entry of the parameters is automatically requested after switching on the mains.

Stored are the following:

- Nominal speed of the turbo pump
- Leak rate of the internal calibrated leak
- Set mass
- Set leak rate unit
and in case of a built-in clock
- Date
- Time.

In order to display these data and to change them, the UL 500 dry has to be set up in the parameter entry mode:

- The UL 500 dry is switched off or must be switched off from normal operation (leave switched off for several seconds).
- Operate the mains switch and **at the same time** press the „OPT“ pushbutton and keep it pressed down further. The alphanumerical display will indicate one after the other:

INFICON AG Remains for 1 s.
PARA INPUT ? EXEC/CLR Now the „OPT“ pushbutton may be released.

- For switching on the PARA mode this question has to be acknowledged by the „EXEC“ pushbutton. (Operating „CLR“ will lead to normal operation.)
After „EXEC“ the following is displayed:

PREPARING PARA INPUT Remains for 1 s
UL 500 dry VERS 1.7 Remains for 1 s.

- Now at first the same selftest of the processors is performed as for normal operation.

PERFORMING SELFTEST

- If this test is performed without errors the UL 500 dry is set to the PARA mode. All programmed parameters can be displayed and changed (for entering any changes numbers can be entered at the flashing positions or the parameter selections selected by the pushbuttons „ARROW RIGHT“ and „ARROW LEFT“). Every selection has to be acknowledged by „EXEC“. Any already programmed parameters can be called up again by „CLR“.

TMP = ? 660 RPS

- The programmed nominal speed of the turbomolecular pump is indicated. (A value between 600 and 720).
If the value is to be changed after exchanging the TMP the number given on the name plate of the pump has to be entered. This name plate is accessible behind the right hand front panel.
- Complete the entry with „EXEC“. The following is displayed:

TESTLK = ? 5.0E-07 ML/S

- Enter the correct value of the calibrated leak (e.g. 6.5E-07 ML/S). This value can be read off the calibrated leak after removing the rear cover of the work panel. Two leak rates are given on the calibrated leak, these being the calibrated leak rate and the effective corrected leak rate due to the mounting situation within the UL 500 dry. The corrected value has to be entered. Permitted range $1 \cdot 10^{-7}$ to $9.9 \cdot 10^{-7}$.
- Complete the entry with „EXEC“. The following is displayed:

MASS = ? 4 u

- Enter the correct mass number (2, 3 or 4 u).
- Complete the entry with „EXEC“. The following is displayed:

LEAKRATE UNIT = ? MLS

- Select the desired leak rate unit with „ARROW RIGHT“ or „ARROW LEFT“ (**MLS** = mbar-l·s⁻¹), ACS = Atm·cc/s, PMS = Pa·m³/s).
- Complete the entry with „EXEC“. The following is displayed:

DATE = ? dd.mm.yy.

- Enter the current date (Day - Month - Year). This is only requested, provided the clock module has been built-in.
- Complete the entry with „EXEC“. The following is displayed:

TIME = ? hh:mm:ss

- Enter the current time (Hour - Minute - Second). This is only requested, provided the clock module has been built-in.
- Complete the entry with „EXEC“.

This completes the entry process and the instrument will automatically start running up the pumps, thereby returning to normal operation.

ANNEX 2

Operation of the UL 500 dry on mass 2 and 3 (Hydrogen)

For special applications the UL 500 dry may be switched from operation on mass 4 (helium) to operation on mass 2 or mass 3 (see Annex 1, PARA MODE).

Mass 2 represents the molecular hydrogen ion H_2^+ and mass 3 the H_3^+ ion, which is produced by addition of the molecular H^+ ion (from H_2O).

Depending on the number of operating hours of the unit, a relatively high hydrogen background may accumulate in the mass spectrometer relative to the detection limit, which requires the adaptation of some automatic sequences especially for operation on mass 2.

The differences are given in Table 1.

Besides for measurements on hydrogen, mass 3 can be used for the detection of $3He$. The UL 500 dry is linear also for this mass, but the detection limit is somewhat reduced because of the existing background.

Table 1 Difference in operation on mass 2, 3 and 4

	Mass 2	Mass 3	Mass 4
Run up	no	no	yes, with internal leak
Sensitivity test			
AUTOTUNE	yes, with background	yes, with background	Test pos.: no Test neg.: yes, with int. leak
ZERO	yes	yes	yes
Lowest display limit:			
VAC ($mbar \cdot l \cdot s^{-1}$)	$2 \cdot 10^{-6}$	$2 \cdot 10^{-9}$	$5 \cdot 10^{-11}$
SNIFF / RATE ($mbar \cdot l \cdot s^{-1}$)	$2 \cdot 10^{-3}$	$2 \cdot 10^{-6}$	$2 \cdot 10^{-7}$
SNIFF / CONC ($mbar \cdot l \cdot s^{-1}$)	$2 \cdot 10^{-3}$	$2 \cdot 10^{-6}$	$2 \cdot 10^{-7}$
CAL INT possible	nein	nein	ja
CAL EXT possible	ja	ja	ja

ANNEX 3

Equipment messages; messages for the operator on the text display

The following messages on the alphanumeric text display inform the user about incorrect entries during certain operating modes. These are listed in the following together with further explanations where applicable.

Messages during LIMIT function

INVALID KEY

An invalid key was operated.

INVALID INTERVAL

The interval selected is too small.

INVALID ARGUMENT

A number should have been entered.

LIMIT LOW<<

Value entered for limit low was too low.

LIMIT LOW>>

Value entered for limit low was too high.

LIMIT HIGH<<

Value entered for limit high was too low.

LIMIT HIGH>>

Value entered for limit high was too high.

NO INTERVAL IN ZERO

It is not possible to enter an interval with upper and lower limit when the Zero function is active.

SET FIRST LIMIT LOW

The upper limit can not be entered before entering the lower limit.

Messages during OPT function

CLEAR CAL EMV

Termination of the CAL EMV process.

PERFORMING CAL EMV

CAL EMV process is running.

PERFORMING AUTOTUNE

The sensitivity alignment for AUTOTUNE is running.

PERFORMING AUTOZERO

The Zero alignment for AUTOZERO is running.

26:NO CALEMV IN STBY

OPT 26: CALEMV is not possible during STANDBY (switch to DETECT).

27:NO EXT-V.24

OPT 27 cannot be carried out as the V.24 interface option has not been built-in.

24:NO TUNE IN DETECT

OPT 24: TUNE is not possible during DETECT (switch to STANDBY).

10:NO TRIGGER

OPT 10 cannot be carried out as the trigger option has not been built-in.

25:NO ZERO IN DETECT

OPT 25: ZERO is not possible during DETECT (switch to STANDBY).

CLEAR AUTOTUNE

Termination of the AUTOTUNE process.

15:OPT UNAVAILABLE

OPT function is not available.

CLEAR AUTOZERO

Termination of the AUTOZERO process.

Messages when pressing other keys

CLEAR CAL EXTERN

Termination of the external calibration process.

CLEAR CAL INTERN

Termination of the internal calibration process.

CAL EXTERN

Running of the external calibration process.

CAL INTERN

Running of the internal calibration process.

DETECTING <INSP>

INSPECT measurement mode.

INVALID ARGUMENT

Entry of a wrong key.

INTERPRETER ERROR

Internal software or hardware error.

DETECTING <MEAS>

MEASURE measurement mode

NO CAL IN <INSPECT>

Calibration during the INSPECT mode is not possible.

NO CAL IN <STANDBY>

In the SNIFF mode only external calibration is possible. Switch to MEASURE.

WARNING:MAX IS ACTIV

For external calibration the MAX function should be switched off.

NO CONC IN <VACUUM>

In the VACUUM mode no concentrations can be displ.

NO CHANGE IN DETECT

Switching to VAC / SNIFF is only possible during STANDBY.

NO INPUT DURING CAL

No entries can be made during a calibration.

NO MAX IN <STBY>

MAX function is only possible during DETECT.

NO MAX IN <INSP>

MAX function is only possible in the MEASURE mode.

NO PREC IN <INSPECT>
PREC is only possible MEASURE mode.

NO ZERO IN <STBY>
The ZERO function is only possible during DETECT.

NO ZERO IN INTERVAL
The Zero function cannot be selected when displaying intervals.

NO INPUT IN REMOTE
No entries can be made via keys when the V.24 interface is active.

RESET MAX
Resetting of the MAX function.

PLEASE SEE OP-MANUAL
Refer to Operating Instructions.

STANDBY FOR <INSP>
STANDBY condition in the INSPECT mode.

STANDBY FOR <MEAS>
STANDBY condition in the MEASURE mode.

TESTLEAK<<
Helium signal of the calibrated leak is too small.

Messages sent by the control processor

AUTOTUNE FINISHED
OPT 24 finished.

AUTOZERO FINISHED
OPT 25 finished.

AUTOTUNE MASS x
AUTOTUNE for mass x running: x=2,3,4

CAL: TUNING MASS x
During calibration: x=2,3,4

CAL: PERFORMING ZERO
Performing Zero alignment during calibration.

CAL: CALIBRATION
Calibration process running.

CALIBRATION FINISHED
Calibration process finished.

CATHODE 2
Switching to cathode 2 after detecting a faulty cathode 1.

CLOSE TESTLEAK! EXEC
For external calibration: Close calibrated leak.

EMISSION OFF
Emission switched off because of a fault.

NOT AVAILABLE
This function has not been implemented.

OPEN TESTLEAK! EXEC
For external calibration:
Open calibrated leak.

OPEN VAR LEAK E-5 MS
During EMV resistance alignment:
Open variable leak.

PERFORMING AUTOZERO
Zero alignment performed during run up.

PLEASE WAIT
Wait until the internal process has been completed.

PREPARING <MEAS>
?When switching from PREC to FINE.

RUNNING UP
The turbo molecular pump is running up.

SELFTTEST WITH ERRORS
Fault during initialization + hardware test.

SENSITIVITY CHECK
Sensitivity check during run up.

SIGNAL IN RANGE
During EMV resistance alignment:
The set leak rate is correct.

SIGNAL STABLE ? EXEC
During external calibration: The operator has to decide whether or not the value is stable after having made changes to the calibrated leak.

SIGNAL TOO HIGH
During EMV resistance alignment:
The leak rate set on the variable leak has been set too high.

SIGNAL TOO LOW
During EMV resistance alignment:
The leak rate set on the variable leak has been set too low.

SNIFF AIR! EXEC
During external calibration:
Place the sniffer tip in air.

SNIFF CONC! EXEC
During external calibration:
Place the sniffer tip in the concentration.

SNIFF TESTLEAK! EXEC
During external calibration:
Place the sniffer tip in the calibrated leak.

STOP: PUMP OVERLOAD
The leak detector has been in the MASSIVE range for over 10 min, and has then switched to STANDBY.

STOP: TM DEFECT
TM P1 or P 2 is faulty.

TOTAL FAIL
The unit was switched off because of a fault.

TUNING MASS x
During TUNE OPT 24 while running. x=2,3,4

ANNEX 4;

Error messages

The UL 500 dry is provided with comprehensive selftest routines. If a fault condition is detected by the control processor a corresponding error message is displayed as far as this is still possible.

The error message is displayed as plain text on the alphanumerical display (8/17) and as code on the seven segment (18/3) display on the front panel of the control processor assembly.

Listed in the following are all possible error messages together with a brief explanation as to the cause of the fault. More details are given in the Service Manual SA 10.204.

Note

When reading „B“ and „6“ on the seven segment display reading errors can easily be made. The letter „B“ is displayed as lower case „b“, the number 6 is displayed with an additional cross bar.

Note:  = B  = 6

The seven segment display is not reset automatically but has to be reset via the pushbutton on the front panel of the STE control assembly (8/2).

Alphanumerical display

Seven segment display

ER: TEMPERATURE>55 °C	01H:
Temperature at the calibrated leak is higher 55 °C.	
ER: TEMPERATURE<10 °C	02H:
Temperature at the calibrated leak is lower than permissible.	
ER: RUNNING UP > 6 min	03H:
Run-up time after switching on the backing pump is too long.	
ER:P1-U <<	04H:
Bridge voltage of the P1 gauge head is too low.	
ER:P1-U>>	05H:
Bridge voltage of the P1 gauge head is too high.	
ER:P2-U <<	06H:
Bridge voltage of the P2 gauge head is too low.	
ER:P2-U>>	07H:
Bridge voltage of the P2 gauge head is too high.	
ER: I-120V I>>	08H:
Supply voltage VN4 is too high.	
ER: I-120V I<<	09H:
Supply voltage VN4 is too low.	

ER:MSP-ANOD-CAT-U>>	0AH:
Difference between anode potential and cathode potential of the mass spectrometer is too high.	
ER:MSP-ANOD-CAT-U<<	0BH:
Difference between anode potential and cathode potential of the mass spectrometer is too low.	
ER:MSP-SUP-POT>>	0CH:
Suppressor potential of the mass spectrometer is too high.	
ER:MSP-SUP-POT<<	0DH:
Suppressor potential of the mass spectrometer is too low.	
ER:MSP-ANOD-POT>>	0EH:
Anode potential of the mass spectrometer is too high.	
ER:MSP-ANOD-POT<<	0FH:
Anode potential of the mass spectrometer is too low.	
ER: +/-15V>>	10H:
Supply voltage VP/VN is too high.	
ER: +/-15V<<	11H:
Supply voltage VP/VN is too low.	
ER: +24V>>	12H:
Supply voltage VP/2 is too high.	
ER: +24V<<	13H:
Supply voltage VP/2 is too low.	
ER:TMP +15V>>	14H:
Voltage of TMP supply is too high.	
ER:TMP +15V<<	15H:
Voltage of TMP supply is too low.	
ER:BATTERY-U<<	16H:
Voltage of the backup battery is too low (applicable only without clock assy.).	
ER:D/A U-REF>>	17H:
Reference voltage on control assy. STE is too high.	
ER:D/A U-REF<<	18H:
Reference voltage on control assy. STE is too low.	
ER:A/D-CONVERTER DEF	19H:
A/D converter on control assy. STE is faulty.	
ER:STE-MUART DEF	1AH:
MUART-IC on the CPU of control assy. STE is faulty.	
ER:EMV-OFFSET>>	1BH:
Electrical offset of the high impedance input amplifier is too high.	

ER:PEAK NOT IN RANGE In TUNE mode no maximum is found within the normal range. Maximum at the range limit.	1CH:	ER:BACKING-P,-I>> Current drawn by the pump combination (TMP and diaphragm pump) is too high.	30H:
ER:SIGNAL NOT STABLE In TUNE mode no stable signal is measured.	1DH:	ER:BACKING-P,-I<< Current drawn by the pump combination (TMP and diaphragm pump) is too low.	31H:
ER:TUNE DIFFERENCE In the TUNE mode the minimum/maximum voltage difference in the normal range is too small for reliable peak detection.	1EH:	ER:TMP U-LINK>> Error message from the turbo pump supply (TPV) when the intermediate DC is too high.	3CH:
ER:CAL-DIFFERENCE<< In the CAL mode the voltage difference maximum/minimum is too small.	1FH:	ER:TMP U-LINK<< Error message from the turbo pump supply (TPV) when the intermediate DC is too low.	3DH:
ER:MSP-SUP-NOM>> Error message from MSV, if the set value is too high in the suppressor control loop.	20H:	ER:TMP I-LINK>> Error message from the TPV if the intermediate circuit dc is too high.	3EH:
ER:MSP-ANOD-NOM>> Error message from MSV, if the set value is too high in the anode potential control loop.	21H:	ER:TMP I-LINK<< Error message from the TPV if the intermediate circuit dc is too low.	3FH:
ER:I-CAT-HEATER>> Error message from MSV, if the cathode current is too high.	22H:	ER:TMP-FREQ>> Error message from the TPV if the nominal speed of the rotor of the turbomolecular pump is too high.	40H:
ER:I-CAT-HEATER<< Error message from MSV, if the cathode current is too low.	23H:	ER:TMP-FREQ<< Error message from the TPV if the nominal speed of the rotor of the turbomolecular pump is too low.	41H:
ER:FUSE-ANO-HEAT DEF Fuse of the anode heating circuit has blown on MSV.	24H:	ER:TMP OVERLOAD-T Error message from TPV in case of over temperature of the motor (T > 65 °C).	42H:
ER:MSV-24V<< Error message from MSV when the supply voltage is too low.	25H:	ER:TMP OVERLOAD-I Error message from TPV in case of over current of the TMP motor (I>12 A).	43H:
ER:NO EMISSION Error message from MSV when the emission current fails.	28H:	ER:TMP OVERLOAD-U Error message from TPV in case of overvoltage of the TMP motor (U>80 V).	44H:
ER:COMPRESSOR-I>> Current of compressor motor is too high.	2CH:	ER:TMP OVERLOAD-FREQ Error message of TPV if the actual speed of the turbopump exceeds the set value.	45H:
ER:COMPRESSOR-I << Current of the compressor motor is too low (is only measured if the signalling pressure switch indicates that the pressure in the vessel has dropped below 1.5 bar).	2DH:	ER:TMP-CONT NO COMMU Connection between TPV assy. and STE assy. is not working properly.	46H:
ER:ROUGHING-P,-I>> Current of scroll pump motor too high.	2EH:	ER:PHASE MISSING In case of 3-phase mains supply one phase is missing.	47H:
ER:ROUGHING-P,-I<< Current of the scroll pump motor too low and the auxiliary pump contactor is active .	2FH:	ER:PHASE SEQUENCE In case of 3-phase mains supply two of the phases are interchanged.	48H:

ER:ROUGHING-P, OVERL Overload of auxiliary pump (contactor not activated).	49H:	ER1:DSR INACTIV Error within the internal V.24 connection.	98H:
ER:TMP35-FREQ<< Speed of the turbo pump is too low.	4A:	ER1:TIME OUT ECHO O. Error within the internal V.24 connection.	9AH:
ER:TMP-VENT V. DEF Venting valve VF2 for turbomolecular pump and rough vacuum does not switch.	50H:	ER1:ACIA-OVERRUN Error within the internal V.24 connection.	9BH:
ER:TESTLEAK V. DEF Calibrated leak valve VT does not switch.	51H:	ER1:DSR AKTIV Error within the internal V.24 connection.	9CH:
ER:COUPLING V. DEF Coupling valve VK does not switch.	52H:	ER1:PARITY-ERROR Error within the internal V.24 connection.	9EH:
ER:BYPASS V. DEF Bypass valve VB does not switch.	53H:	ER1:DATA LOST Error within the internal V.24 connection.	9FH:
ER:INLET V. DEF Inlet valve VE does not switch.	54H:		
ER:ROUGHING V. DEF Auxiliary pump valve VH does not switch.	55H:		
ER:VENTING V. DEF Venting valve VF1 does not switch.	56H:		
ER:GASBALLAST V. DEF Gas ballast valves VG1 / VG2 do not switch (only with built-in option).	57H:		
ER:COMPRESSOR-P<< Pressure in the compressor vessel is too low.	5AH:		
ER1:STATUS-CRC-ERROR Error during check of status byte.	60H:		
ER1:INVALID STATE Invalid equipment status.	61H:		
ER1:INVALID STRING Invalid data or commands on the internal V.24 interface.	62H:		
ER1:VERSION CONFLICT Software conflict between the two processors.	91H:		
ER1:CHECK ERROR E.O. Error within the internal V.24 connection.	92H:		
ER1:CHECK ERROR ID Error within the internal V.24 connection.	93H:		
ER1:TIME OUT IDENT Error within the internal V.24 connection: Connection not acknowledged by the other end.	95H:		
ER1:TIME OUT INIT Error within the internal V.24 connection.	96H:		
ER1:DSR INACTIV INIT Error within the internal V.24 connection.	97H:		

This page has been left blank for your comments.

