

OPERATING INSTRUCTIONS

GA05228_0302

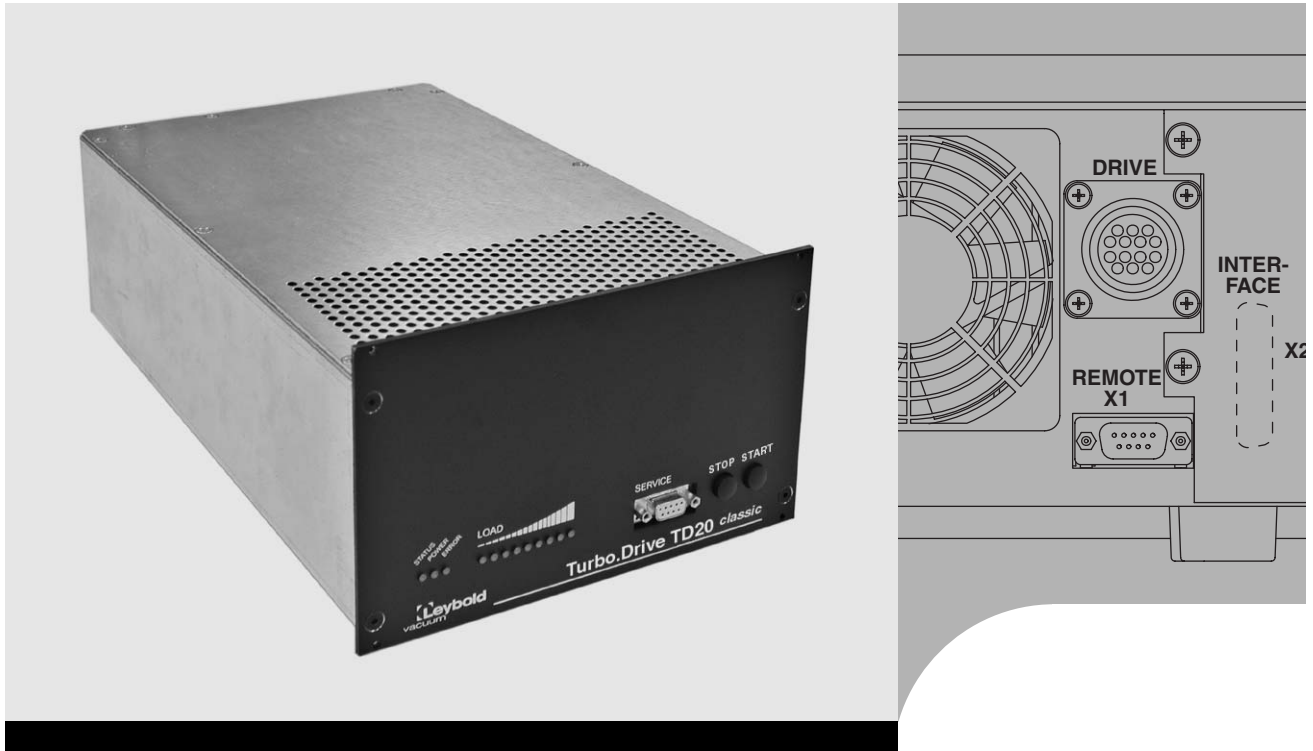

Turbo.Drive TD20 *classic*

Frequency Converter for
Turbomolecular Pumps

Part Nos.

800075V0001 to
800075V0007

 **Leybold**
vacuum

Section		Page
	Important Safety Information	3
1	Description	4
1.1	Design and function	4
1.2	Supplied equipment	4
1.3	Technical data	6
1.4	Ordering information	7
1.5	Accessories	7
2	Installation	8
2.1	Placement	8
2.2	Conforming utilisation	8
2.3	Providing the connections	9
2.4	Replacing the NT 20	10
2.5	Replacing the NT 151/361 or NT 361	11
3	Operation	13
3.1	Start-up	13
3.2	Interfaces	14
3.2.1	9-way PLC interface	14
3.2.2	RS 232 interface	15
3.2.3	Profibus interface	16
3.2.4	RS 485 interface	16
3.2.5	25-way PLC interface	18
3.2.6	DeviceNet interface	20
3.2.7	Ethernet/IP interface	20
3.2.8	Parameter list	21
3.2.9	Specific parameter data for the pumps	25
3.2.10	Error messages	26
3.3	Start-up of the TURBOVAC	27
3.4	Operation	27
3.4.1	Status table at default settings	27
3.5	Shut-down of the TURBOVAC	28
3.6	Shut-down of the Turbo.Drive TD20 classic	28
4	Maintenance	28
5	Troubleshooting	29
	EC Conformance Declaration	31

Important Safety Information

Indicates procedures that must be strictly observed to prevent hazards to persons.

Warning

Indicates procedures that must be strictly observed to prevent damage to, or destruction of the product.

Caution

The Leybold Turbo.Drive TD20 *classic* frequency converter has been designed for safe and efficient operation when used properly and in accordance with these Operating Instructions. It is the responsibility of the user to carefully read and strictly observe all safety precautions described in this section and throughout the Operating Instructions. The Turbo.Drive **must only be operated in the proper condition and under the conditions described in the Operating Instructions**. It must be operated and maintained by trained personnel only. Consult local, state, and national agencies regarding specific requirements and regulations. Address any further safety, operation and/or maintenance questions to your nearest Leybold Vacuum office.



Only qualified personnel or the Leybold Service Department may carry out work on the frequency converter.

Warning

Potentially fatal voltages are present inside the frequency converter.



Open the frequency converter only after it has been isolated from the mains power supply.

We reserve the right to alter the design or any data given in these Operating Instructions. The illustrations are not binding.

1 Description

1.1 Design and function

The electronic frequency converter Turbo.Drive TD20 *classic* is used to drive the following turbo molecular pumps:

TURBOVAC 151, 151 C, 361, 361 C,

TURBOVAC 600, 600 C,

TURBOVAC 1000, 1000 C, 1100 C.

These pumps each comprise a three-phase asynchronous motor with the appropriate rating to drive the rotor.

The Turbo.Drive TD20 *classic* converts the single-phase mains voltage into a three-phase AC voltage with regulated frequency and amplitude.

Coding

Each installed TURBOVAC has been individually coded. The acceleration sequence, the regulation during operation, and the output speed will vary depending on the installed pump model.

The Turbo.Drive TD20 *classic* has a 9-way PLC interface as standard and additional interfaces as option. It can be connected directly to mains voltage.

The Turbo.Drive TD20 *classic* can be connected directly to mains voltage.

1.2 Supplied equipment

Turbo.Drive TD20 *classic* table-top electronic frequency converter with housing, Operating Instructions.

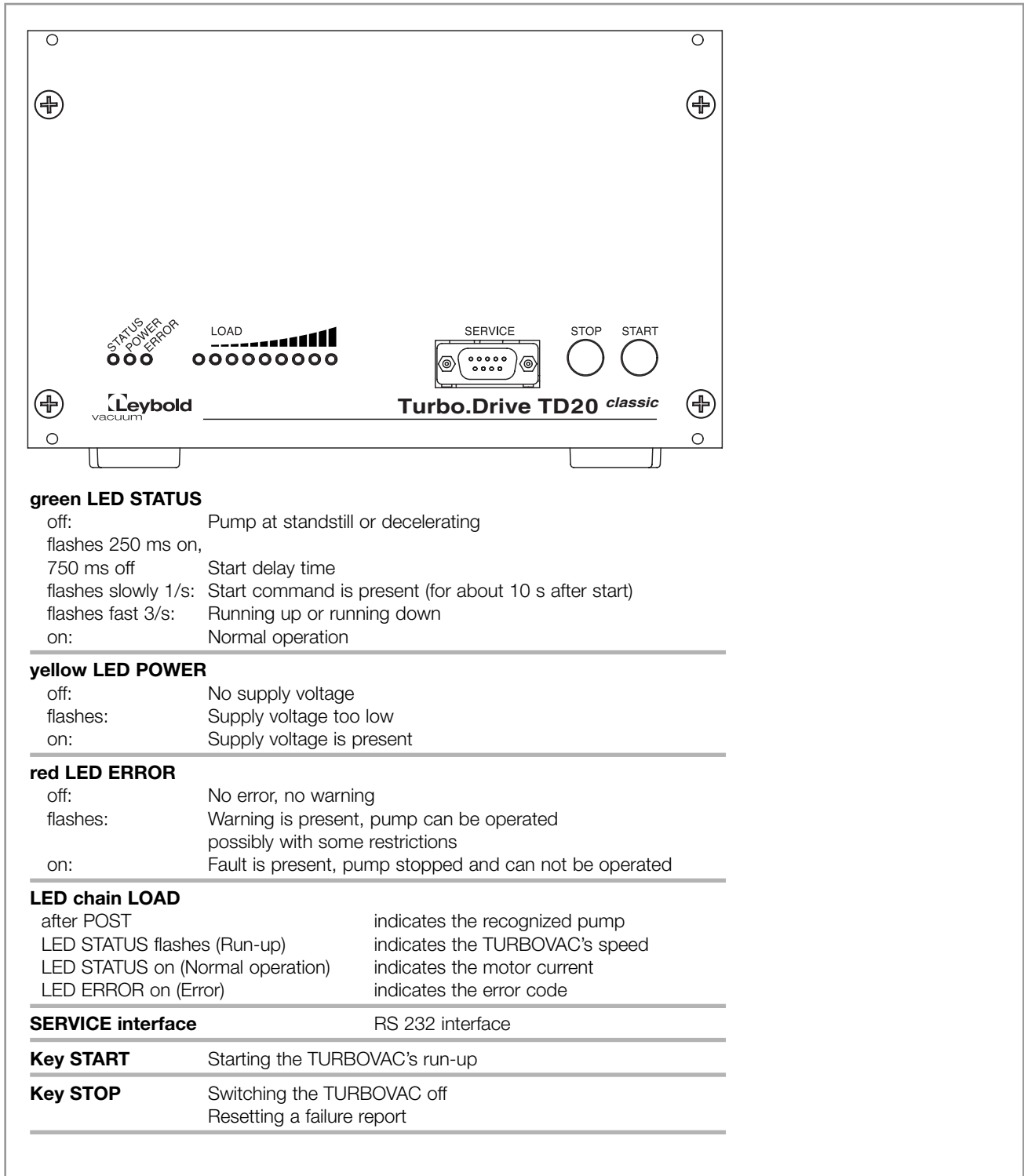

Fig. 1 Front panel of the Turbo.Drive TD20 classic

Description

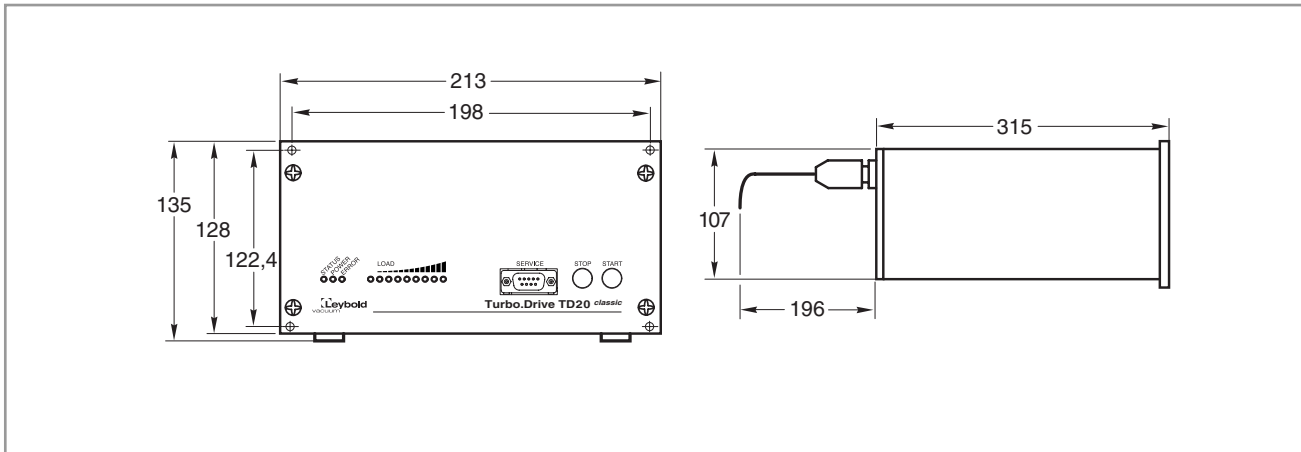

Fig. 2 Dimensional drawing for the Turbo.Drive TD20 *classic*, dimensions in mm

1.3 Technical data

Mains connection	100 to 240 V AC -15%/+10%, 50/60 Hz
Power consumption tolerance including options	< 500 VA
Power consumption of the TURBOVAC	< 400 VA
Power output (motor)	
Nominal voltage	47 V
Motor current limitation	
Acceleration (max. 10 min.)	5 A
Continuous operation	3.5 A
Frequency	0 to 835 Hz

TURBOVAC speed ratings





TURBOVAC 151	49,980 min ⁻¹
TURBOVAC 361	45,000 min ⁻¹
TURBOVAC 600	36,000 min ⁻¹
TURBOVAC 1000	36,000 min ⁻¹
TURBOVAC 1100	30,000 min ⁻¹

Ambient temperature	0-45 °C
Storage temperature	-25 °C...+70 °C
Relative air humidity	5 to 85 % (non-condensing)
Type of protection to EN 6059	IP 20
Electrical safety to EN 61010-1	
Interference radiation to 61326-1	Class A
EMC to IEC 801-2	Severity 2
Dimensions	1/2 19", 3HU
Weight	4 kg

1.4 Ordering information

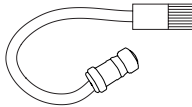
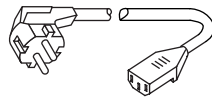
	Part No.
Frequency converter Turbo.Drive TD20 <i>classic</i>	
with 9-way PLC interface	800075V0001
with additional RS 232 interface	800075V0002
with additional Profibus interface	800075V0003
with additional RS 485 interface	800075V0004
with additional 25-way PLC interface	800075V0005
with additional DeviceNet interface	800075V0006
with additional Ethernet/IP interface	800075V0007

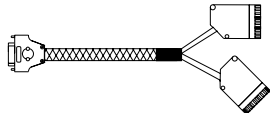
1.5 Accessories

Connection line to the TURBOVAC		
3 m long	857 65	
5 m long	857 66	
10 m long	857 67	
20 m long	857 68	
Power line cord		
2 m long, Euro plug	800102V0001	
2 m long, US plug 6-15 P	800102V1001	
3 m long, Euro plug	800102V0002	
3 m long, US plug 6-15 P	800102V1002	
Plug for 9-way PLC connector with integrated ON/OFF switch for the pump	152 48	
Mounting frame 19", 3HU	161 00	
Adapter cable, 0.2 m long, 25-way PLC interface – 2x Phoenix connector of the NT 20	800152V0020	
Adapter cable, DRIVE connector of the Turbo.Drive TD20 <i>classic</i> – TURBOVAC connection cable of the NT 151/361 or NT 361	800 000 006	

Accessories for serial interfaces

PC software "Turbo.Drive Server" for Windows 95 and higher, CD-ROM	
<ul style="list-style-type: none"> ■ Display, change, save and compare parameter lists ■ Integration of customer's software ■ Record parameter data 	800110V0102
(Software supports only RS 232, RS 485 and Profibus)	
The software can also be downloaded from www.leybold.com in the menu Support & Downloads	

2 Installation

Warning



Only qualified personnel or the Leybold Service Department may carry out work on the frequency converter.

Potentially fatal voltages are present inside the frequency converter.

Open the frequency converter only after it has been isolated from the mains power supply.

2.1 Placement

Place the Turbo.Drive TD20 *classic* on a flat, smooth surface.

For installation in a rack use the mounting frame 19", 3 HU.

Warning



The heat dissipation of the Turbo.Drive TD20 *classic* must not be obstructed. Insure a sufficient ventilation - the ambient temperature during operation must not exceed 45 °C (113 °F).

Warning



If the Turbo.Drive TD20 *classic* is built into a rack the mains plug is not within easy reach. Therefore install a separation between the Turbo.Drive TD20 *classic* and the mains when you build it into a rack.

Warning



Do not operate the Turbo.Drive TD20 *classic* with the standard mains lead in chemically aggressive surroundings. If you operate the Turbo.Drive TD20 *classic* in chemically aggressive surroundings replace the mains lead by a resistant one.

2.2 Conforming utilisation

The electronic frequency converter Turbo.Drive TD20 *classic* is used to drive the following turbo molecular pumps:

TURBOVAC 151, 151 C, 361, 361 C,

TURBOVAC 600, 600 C,

TURBOVAC 1000, 1000 C, 1100 C.

Other turbomolecular pumps **must not** be connected.

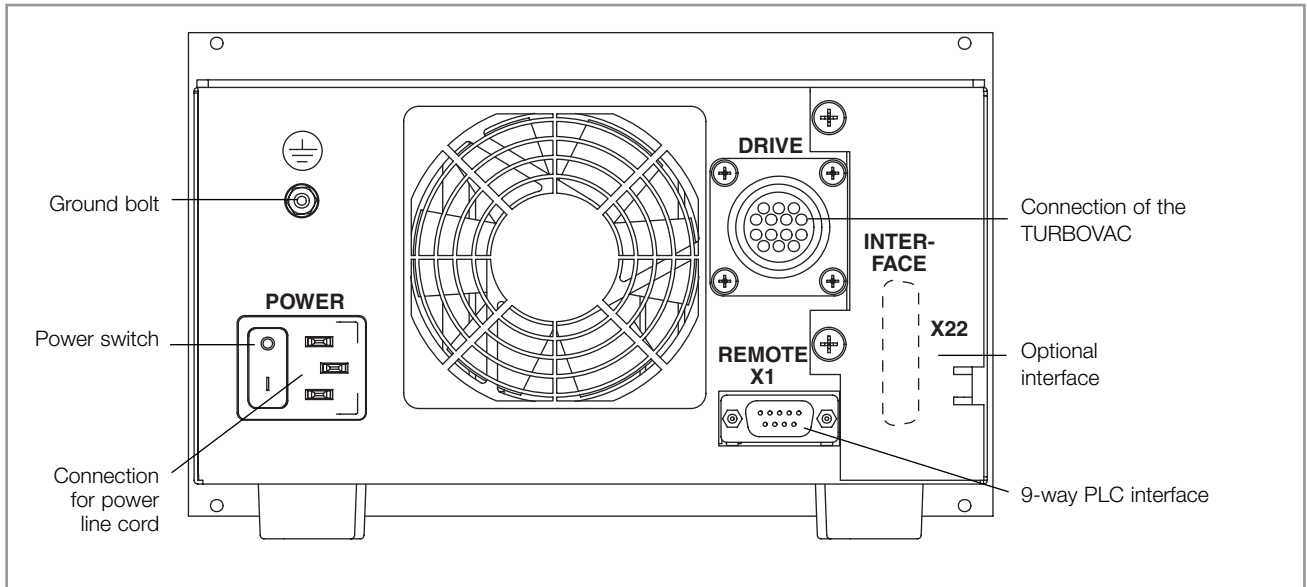

Fig. 3 Turbo.Drive TD20 *classic*, rear panel

2.3 Providing the connections

Insert and fasten the connection line to the motor of the TURBOVAC.

Connect the interface, see Section 3.2.

Connect the instrument using the ground bolt to the protective ground system.

Connect the power line cord.

Warning



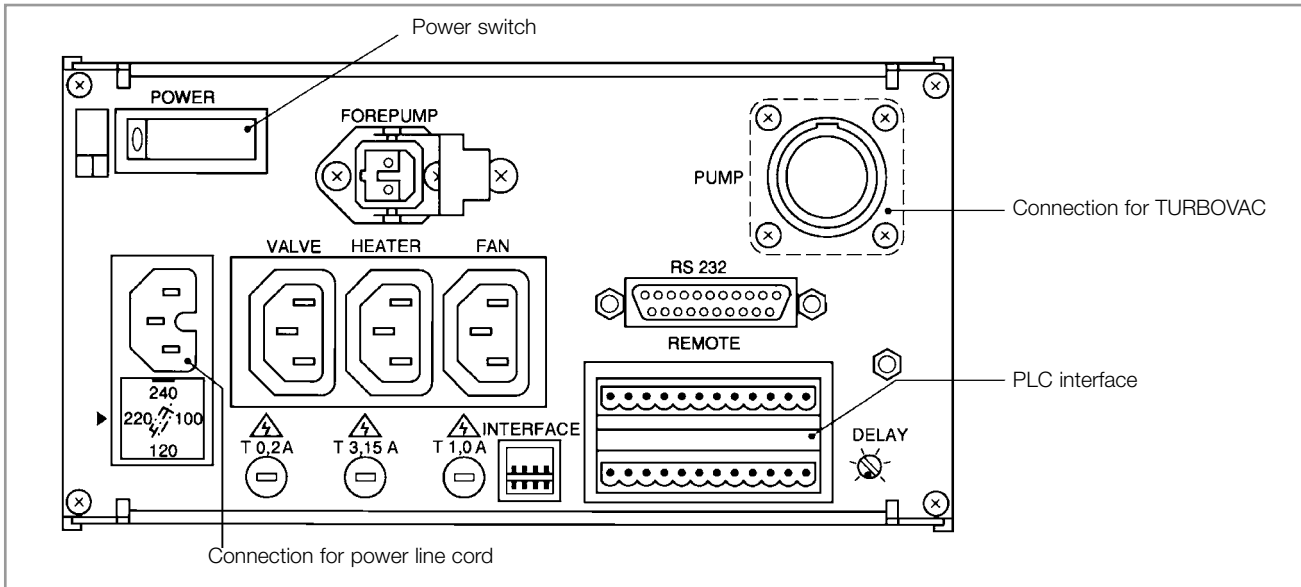

Fig. 4 TURBOTRONIK NT 20, rear panel

2.4 Replacing the NT 20

The Turbo.Drive TD20 *classic* is capable of replacing the NT 20.

The connection for the **power line cord** is identical, an adjustment to the mains voltage is no longer required.

The connection for the **TURBOVAC** is identical. You can use the old connection cable.

The connections FOREPUMP, VALVE, HEATER and FAN are no longer present on the Turbo.Drive TD20 *classic*. Connect corresponding equipment directly to the system controller.

The DIP switches (INTERFACE) need no longer to be set up, the Turbo.Drive TD20 *classic* is capable of detecting the pumps automatically, see Section 3.1 Start up.

The PLC interface **REMOTE** has been replaced

- for some functions by the standard 9-way PLC interface REMOTE X1.
- for all functions by the optional 25-way PLC interface. When wanting to continue to use the old cable with the Phoenix contact strips, we are offering for this purpose an adapter, see Section 1.5 and Fig. 5.

The pin assignments of both interfaces are detailed in Section 3.2.1 and 3.2.5.

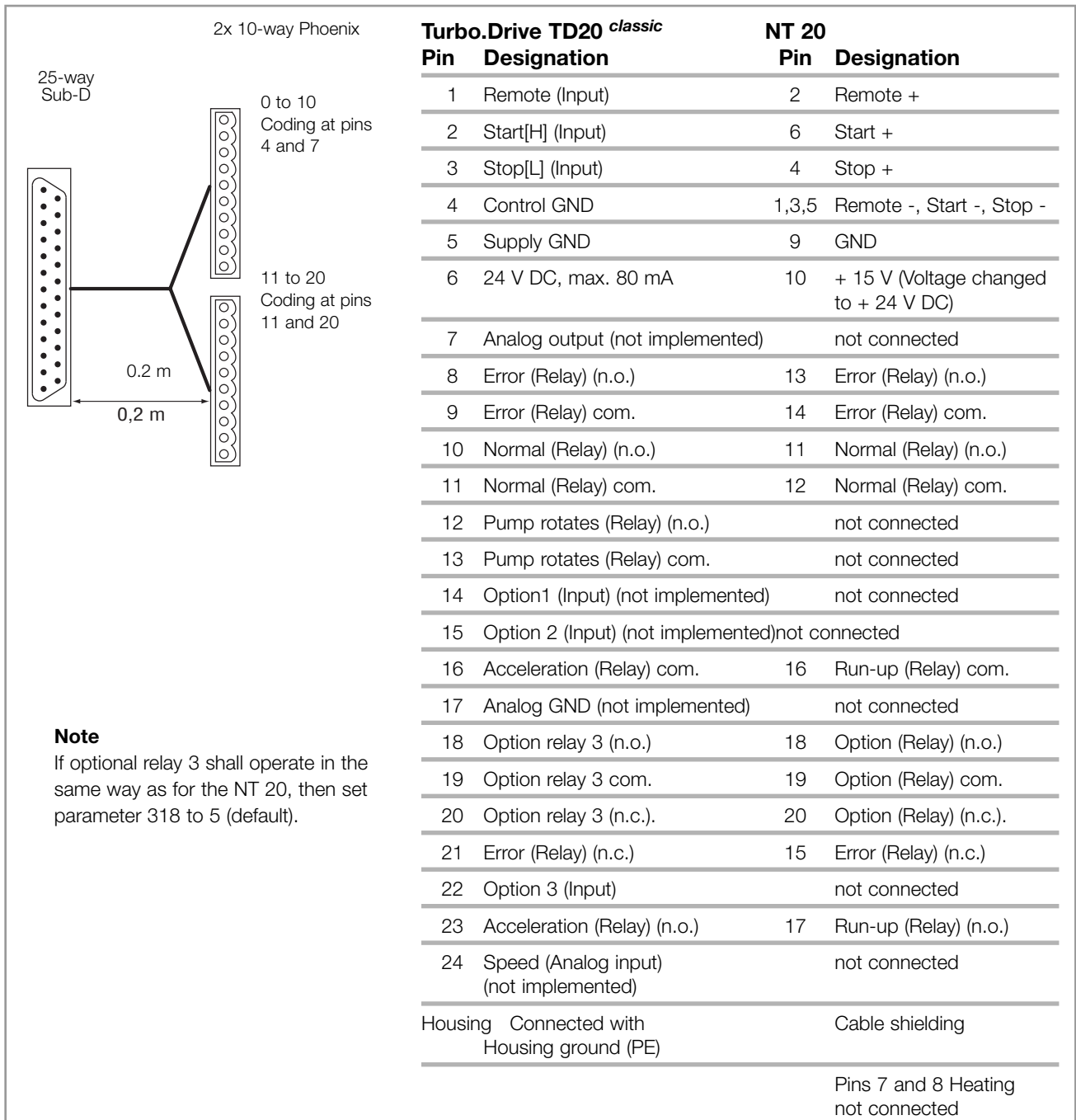

Fig. 5 NT 20 adapter

2.5 Replacing the NT 151/361 or NT 361

The Turbo.Drive TD20 *classic* is capable of replacing the NT 151/361 and the NT 361.

The connection for the **power line cord** is identical, an adjustment to the mains voltage is no longer required. You can use the old power line cord.

The connection for the **TURBOVAC** is different. We recommend using a new connection cable. If you want to use the old connection cable you need the adapter cable 800 000 006.

Installation

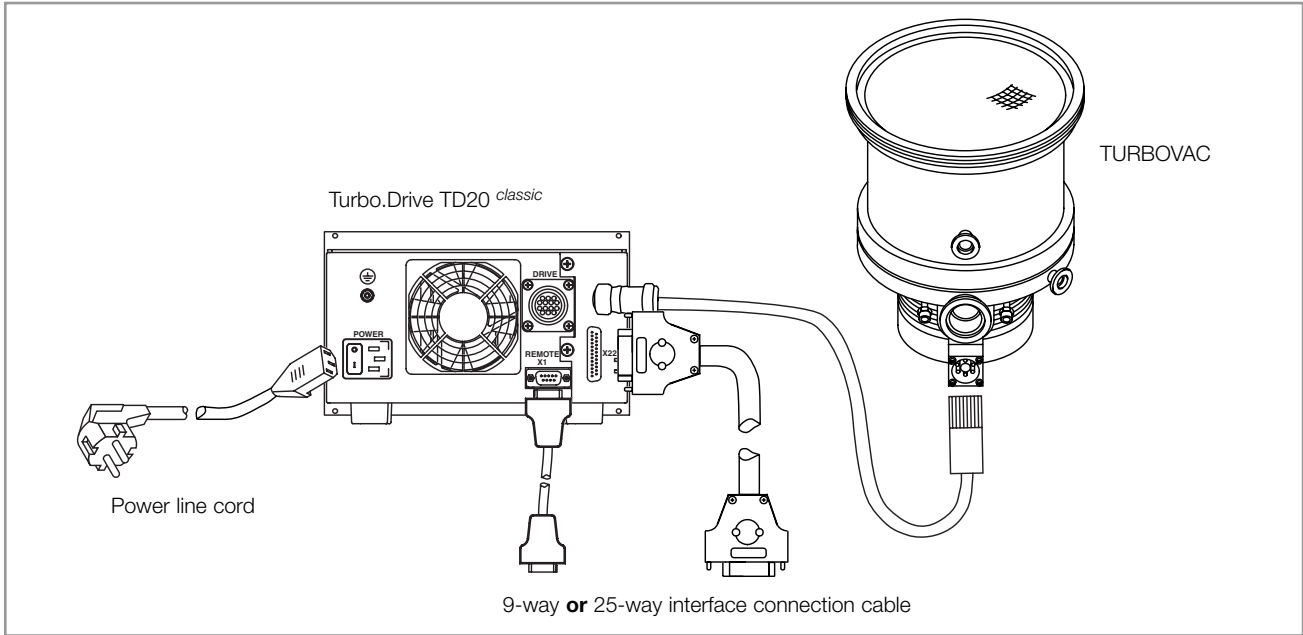

Fig. 6 Connections for the Turbo.Drive TD20 *classic*, schematic representation

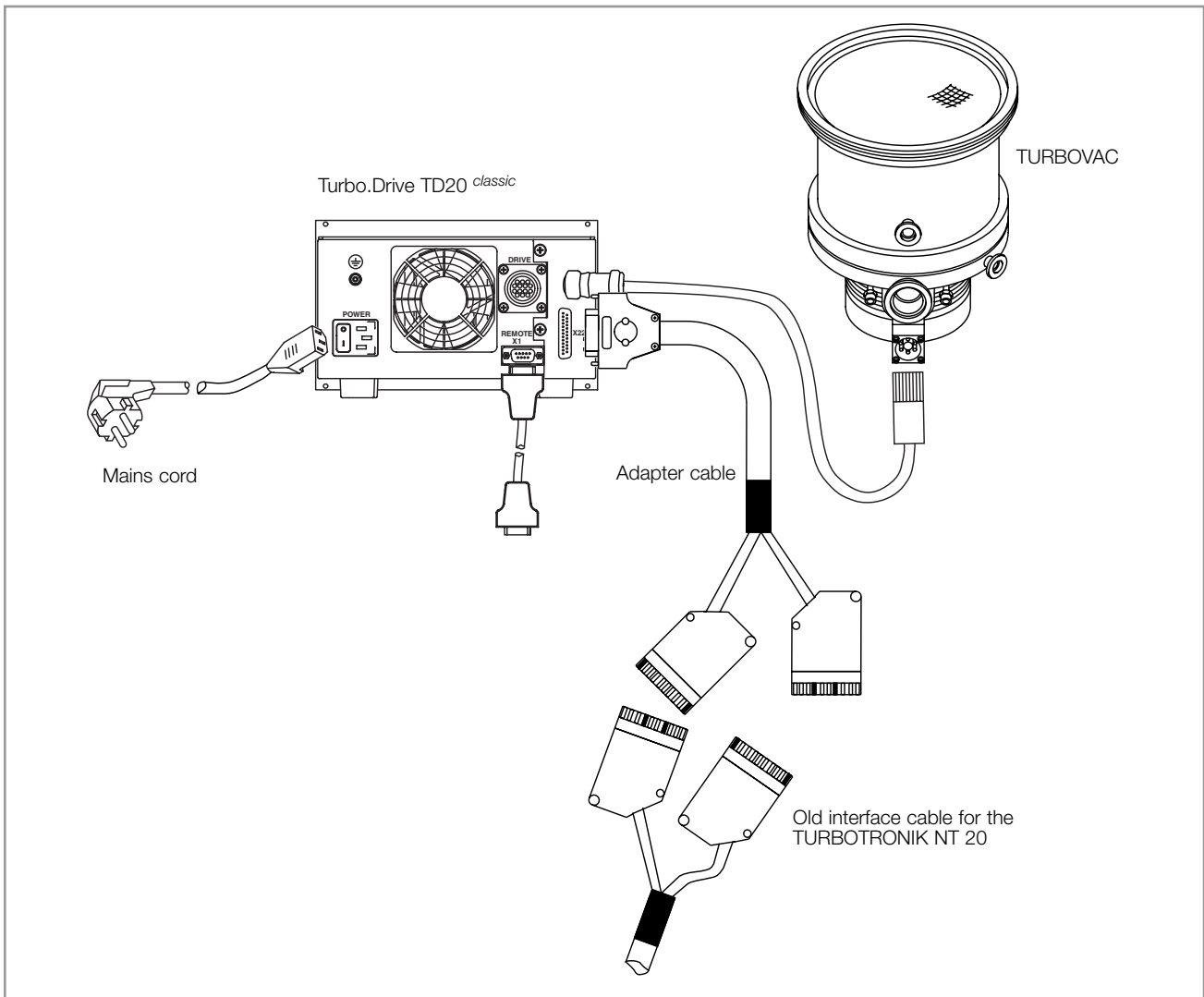

Fig. 7 Connections for the Turbo.Drive TD20 *classic*, with adapter cable, schematic representation

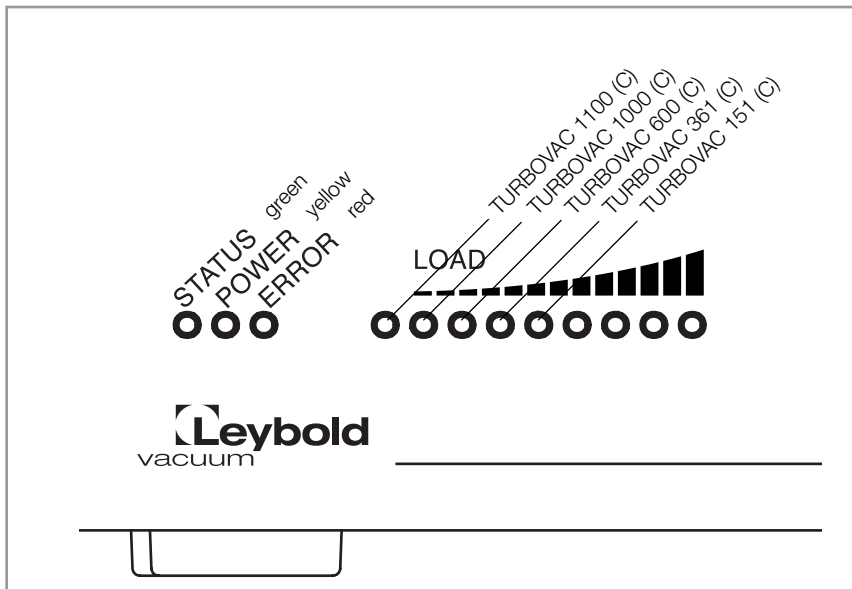

Fig. 6 Pump identification at the LOAD LEDs

3 Operation

Controlling the instrument through the keys START and STOP and the 9-way PLC interface has equal priority. When controlling the instrument through optional boards (Profibus or RS 485, for example), the keys and the 9-way PLC interface are disabled.

3.1 Start-up

Switch the frequency converter on via the switch on the rear.

After doing so, the parameters stored in the EEPROM are read and the connected pump is detected. During this process the LEDs LOAD light up cyclically. After approximately 4 seconds the frequency converter is ready to start.

If after this process the red LED ERROR is on, then the connected pump was not detected. If, moreover, two of the LEDs LOAD flash alternately, then a different pump was detected (long flashing intervals: detected pump; short flashing intervals: stored pump; for pump assignments refer to Fig. 6).

In both cases a special acknowledgement will be necessary: while keeping the STOP key depressed, press the START key and release it again, thereafter release the STOP key.

Through this special acknowledgement process the user acknowledges the change of pump and the correctness of the pump which has been detected.

Caution

Upon delivery, the Turbo.Drive TD20 *classic* has been preset to the TURBOVAC 1100 so the special acknowledgement process will have to be run when commissioning any other pump for the first time.

Note

3.2 Interfaces

The Turbo.Drive TD20 *classic* is equipped as standard with a 9-way PLC interface and optionally with one more:

- RS 232
- Profibus
- RS 485
- 25-way PLC interface
- DeviceNet
- Ethernet

The Turbo.Drive TD20 *classic* is configured through the parameters according to the parameter list. Pxxx denotes parameter value xxx.

The PC software "TURBO.DRIVE Server" allows convenient access by the user to the parameters of the frequency converter.

For further information on the interfaces refer to the Operating Instructions which are included with the respective device.

3.2.1 9-way PLC interface

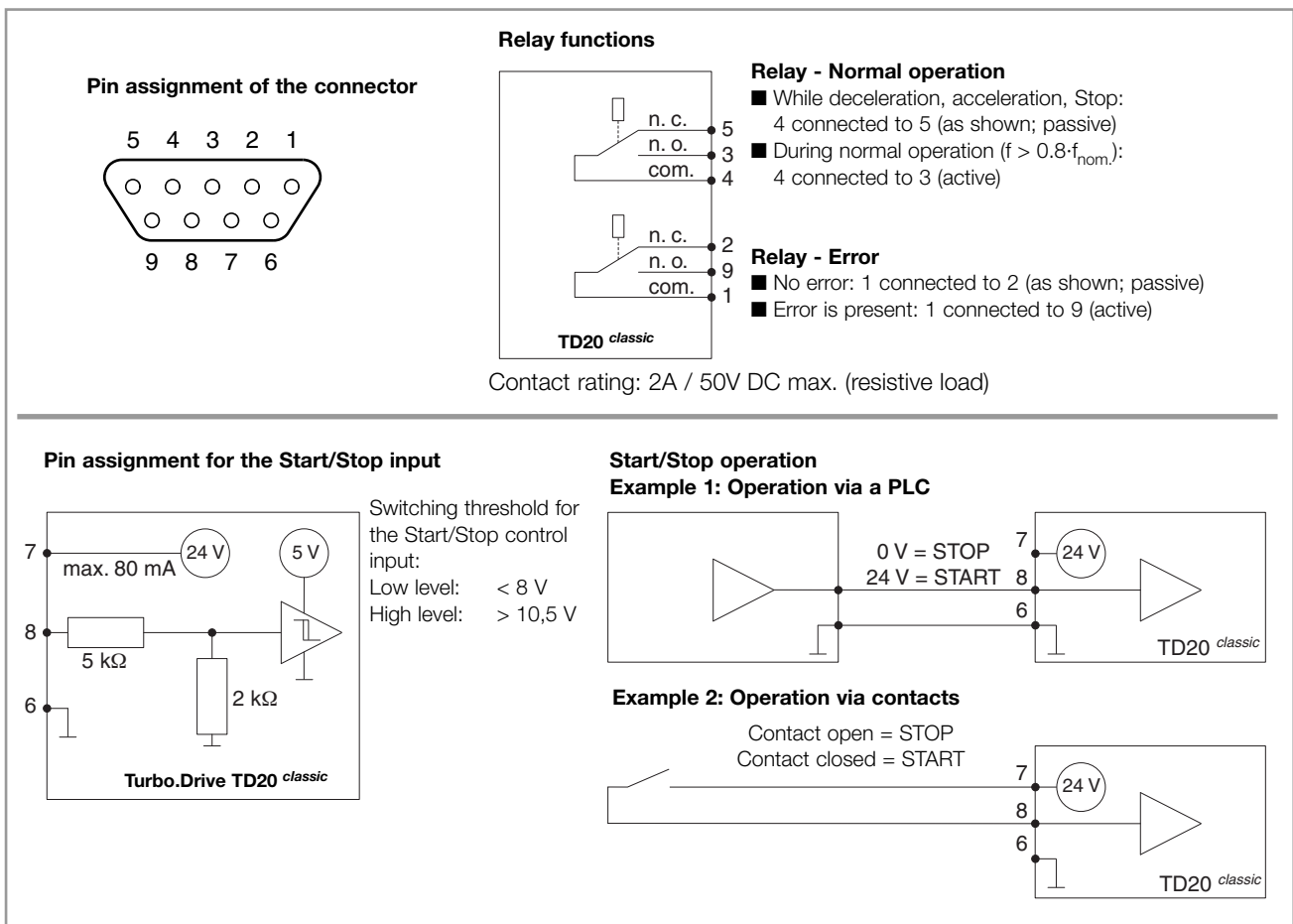

Fig. 9 9-way PLC interface

3.2.2 RS 232 interface

Standards	DIN 66020
Protocol	acc. to VDI/VDE 3689
Transmission rate	19200 baud
Response delay	default setting 10 ms (parameter 180)
Address range	non-addressable
Max. cable length	15 m
Interface connector	9 way Sub-D type, socket on the instrument (female) thread UNC4-40

Note: If on the controlling side an RS 232 interface in accordance with the PC standard with a 9-pin Sub-D male connector is present, then a straight through cable as shown in Fig. 11 may be used.

For further information please refer to the Operating Instructions 17200048.

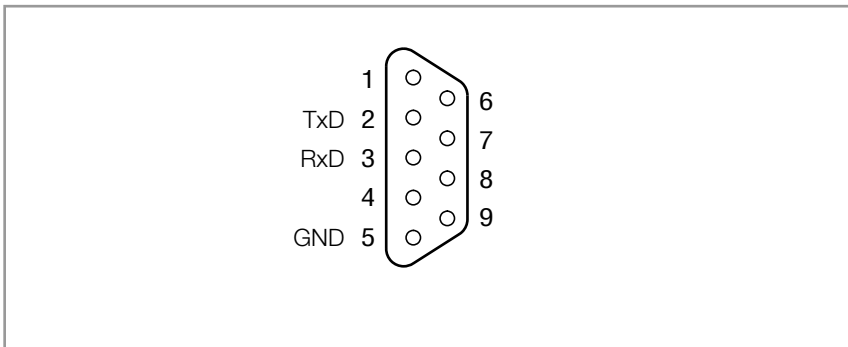

Fig. 10 Pin assignment for the socket at the frequency converter (female)

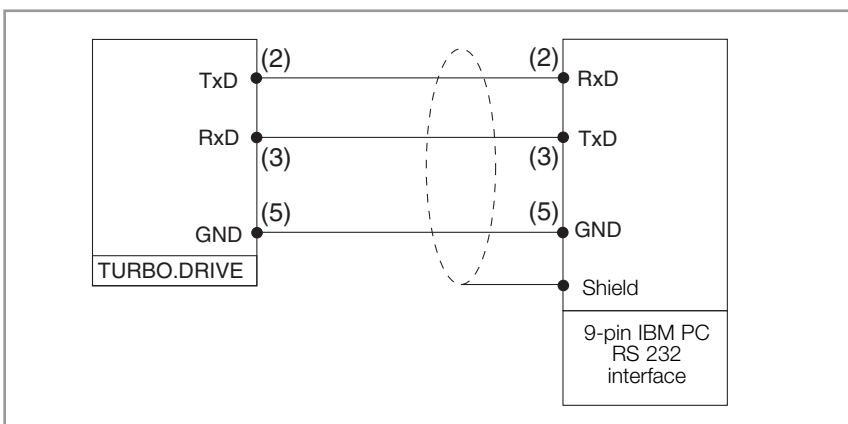

Fig. 11 Providing a RS 232 connection

3.2.3 Profibus interface

Please refer to the Operating Instructions 17200049.

3.2.4 RS 485 interface

Standards	ISO/IEC 8482, EIA 485
Protocol	acc. to VDI/VDE 3689
Transmission rate	19200 baud fixed
Response delay	default setting 10 ms (parameter 180)
Address range	0 ... 15
Max. cable length	50 m (with bus termination)
Type of cable	2 wire twisted pair (twisted pair cable)
Differential voltage levels (see also "Standards")	logic "0": transmitter: 1.5 ... 5 V receiver: > 0.3 V logic "1": transmitter: - 1,5 ... - 5 V receiver: ≤ - 0,3 V
Interface connector	9 way Sub-D type, socket on the instrument (male) thread UNC4-40

Note: After having changed the bus address through the rotary switch, the frequency converter must be switched off (yellow power LED off) and then on again so as to enable the new address setting.

For further information please refer to the Operating Instructions 17200048.

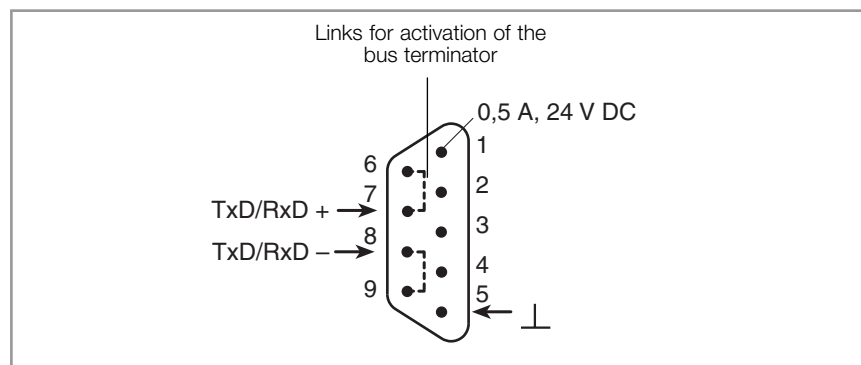

Fig. 12 Pin assignment for the socket at the frequency converter for RS 485 interface (male)

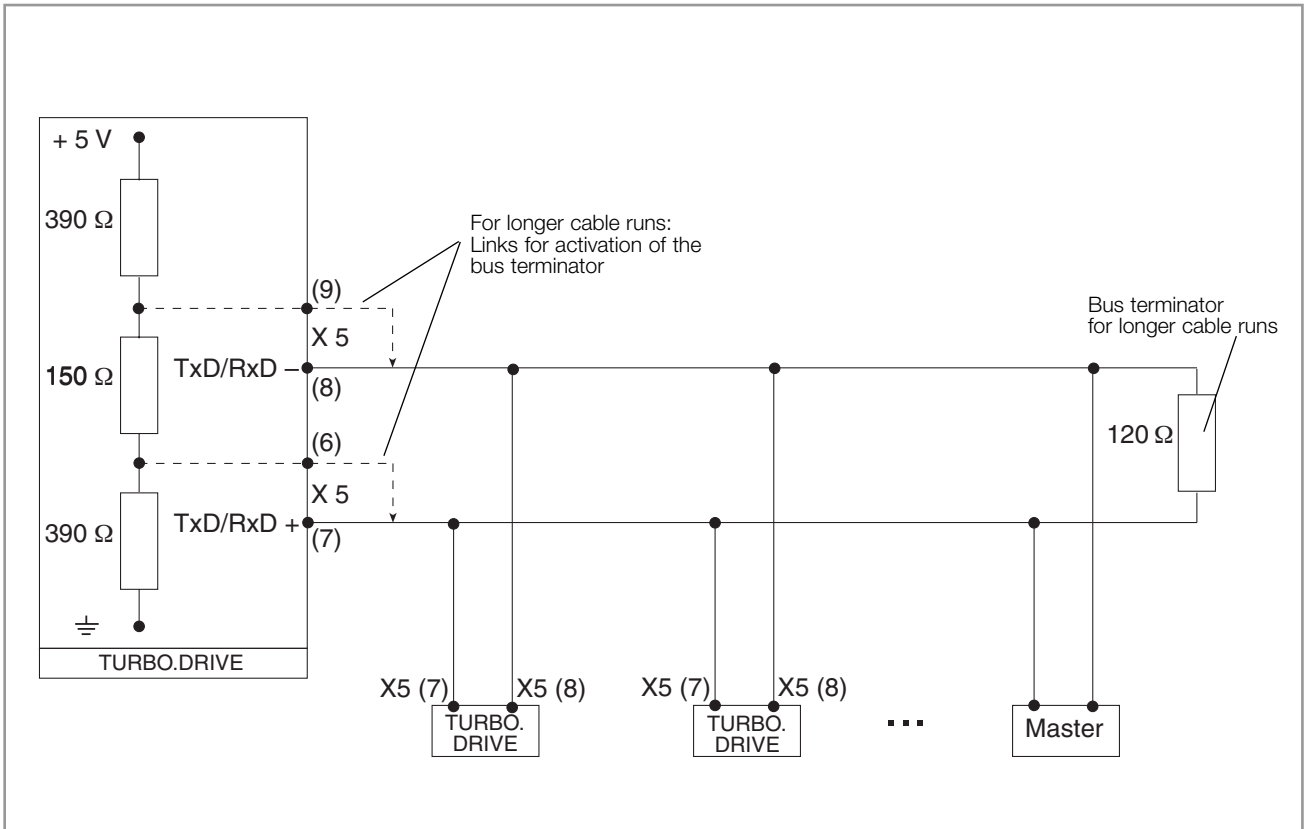

Fig. 13 Connection of the RS 485 bus

Operation

3.2.5 25-way PLC interface

Observe the EMC requirements when connecting the control cables.

Pin assignment for the 25-way PLC interface

Pin	Assignment	Function	Ref. potential
1	Remote[H] (input)	Activates by a H level the inputs Start[H], Stop[H], option 1 to 3 [H]	Control GND
2	Start[H] (input)	PLC H pulse starts the pump, provided Remote[H] = H (duration > 99ms)	Control GND
3	Stop[L] (input)	PLC L pulse stops the pump, provided Remote[H] = L (duration > 99ms)	Control GND
4	Control GND	Reference ground for floating PLC control inputs	
5	Supply GND	Reference ground of for auxiliary power supply pin 6, Reference ground for the analog output pin 7 (see below)	
6	PLC-H signal and power supply	Auxiliary power supply for externally connected equipment. The output voltage corresponds mainly to the input voltage delivered by the host, output voltage 124v DC Current output 80 mA Current limiting without foldback characteristic, no shutdown in case of excessively high currents, however shutdown in case of overtemperatures.	Supply GND
7	Analog output (option)	Programmable analog output 0...10V Not implemented	Supply GND
8	Error (relay)	Collective error message, active in case of a fault (n.o.)	Pin 8
9	Error (relay)	Collective error message, com.	
10	Normal (relay)	Final rotational frequency has almost been attained (n.o.). For For function and threshold the parameters 25, 27 and 29 apply. See parameter 237	Pin 11
11	Normal (relay)	Final rotational speed has almost been attained, com.	
12	Option relay 2	Normally open contact (n.o.) enabled with valve and forevacuum; see parameter 240	Pin 13
13	Option relay 2	com.	
14	Option1 (input)	Not implemented	Control GND
15	Option 2 (input)	Not implemented	Control GND
16	Option relay 1	Assigned to run-up, com.; see parameter 239	
17	Analog	GND reference potential for the analog input (difference measurement)	
18	Option relay 3	Normally open contact (n.o.).assigned with function "FAN"; see parameter 318	Pin 19
19	Option relay 3	com.	
20	Option relay 3	n.c.	Pin 19
21	Error (relay)	Collective error message (active in case of a fault), (n.c.)	Pin 8
22	Option 3 [H] (input)	Not implemented	Control GND
23	Option relay 1	Is enabled in case of a speed increase, normally open (n.o.); see parameter 239	Pin 16
24	Frequency (option) (analog input)	Not implemented	Analog GND
Casing	Frame GND	Connected to frame ground (PE)	

PLC = Programmable logic controller

[H] = PLC high level > 11 V
Input resistance 5...6kΩ

[L] = PLC low level < 8 V
External voltage resistance ± 40VDC

Relays

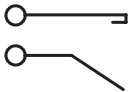
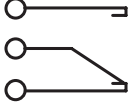
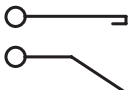
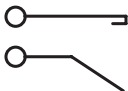
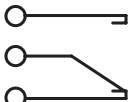
Pin Relay		Possible cause	
10	Normal n.o.		Contact closed: Rotor speed has attained 80% of its nominal speed. (= normal operation). The relay picks up as soon as the normal operation threshold is attained.
11	Normal com.		
8	Fault n.o.		Outputs an error message. When the error relay switches, the pump is shut down. The relay is energised in the case of normal operation. Possible error causes: <ul style="list-style-type: none"> ■ The pump was overloaded for a longer period of time. ■ The minimum rotational speed was not attained within a limited period of time. ■ The speed has dropped below the lower limit. ■ The rotor or bearing temperature is above the fault limit. ■ Internal electrical error.
9	Fault com.		
21	Fault n.c.		
Optional relay 1			Switches when the pump is being driven, the pump is running up.
23	Run-up n.o.		
60	Run-up com.		
Optional relay 2			Switches when: start command is present, no error and mains power on. Can be used to control a valve or the backing pump.
12	Valve and forevacuum n.o.		
13	Valve and forevacuum com.		
Optional relay 3			Supplies a start signal for the connected fan.
18	Fan n.o.		
19	Fan com.		
20	Fan n.c.		

Contact rating: 2A / 50V DC max. (resistive load)

Operation

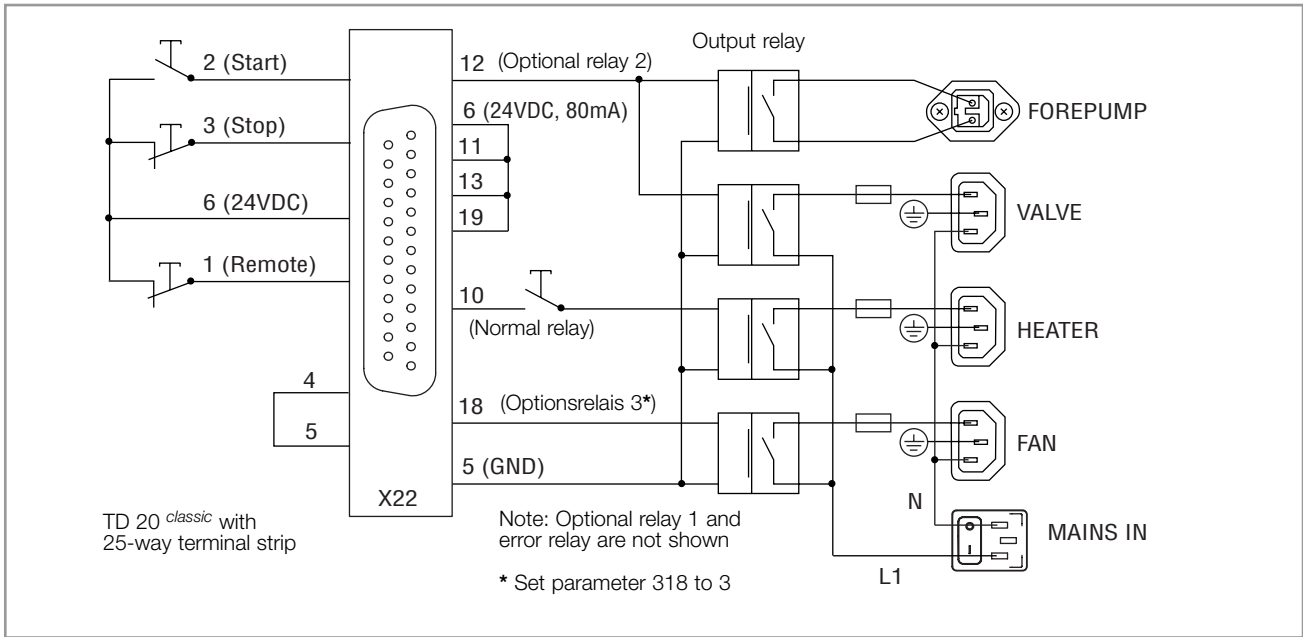

Fig. 14 Example for external connections compatible with the NT 20

3.2.6 DeviceNet interface

See additional Operating Instructions 17200055.

3.2.7 Ethernet/IP interface

See additional Operating Instructions 17200056.

3.2.8 Parameter list

* specific values for each pump; see table of pumps, Section 3.2.9; r = readable, w = writable

No.	Designation	min.	max.	Default	Unit	r/w	Format	Description
1	Converter type	100	160	160	-	r	u16	160 = TurbeDrive TD20 <i>classic</i>
2	Software version x.yy.zz	0	65535	9059		r	u16	
3	Actual frequency	0	1000	0	Hz	r	u16	x.yy: Version, zz: Correction index
4	DC supply voltage	0	1000	0	0.1 V	r	u16	Rotary frequency of the rotating stator field
5	Actual current	0	100	0	0.1 A	r	u16	Constantly measured RMS value of the motor current.
8	Program EEPROM	-32768	32768	0		w	s32	A write command with any number value will initiate carrying over of the data.
11	Actual converter	0	150	0	°C	r	u16	Constantly measured converter temperature.
17	Nominal motor current	0	100	70	0.1 A	r	u16	Maximum motor current
18	Max. frequency	0	1000	*	Hz	r	u16	Upper frequency limit.
19	Minimum setpoint frequency for the pump	P20	P18	500	Hz	r	u16	Lowest permissible frequency
20	Critical frequency	0	P18	*	Hz	r	u16	When the pump is accelerating this frequency must be reached within the maximum passing time (P183). After the end of acceleration: Switch-off threshold because of overload.
21	Max. current factor	0	100	73	%	r	u16	After attaining normal operation, the maximum motor current is limited to P17*P21.
23	Pump type	0	99	*		r	u16	*
24	Setpoint frequency	P19	P18	*	Hz	r	u16	Nominal frequency of the rotating stator field.
25	Frequency dependent normal operation threshold	70	85	80	%	r/w	u16	Defines from which frequency onwards there is normal operation for the pump.
27	Relay definition	0	P17	20	0.1 A	r/w	u16	If P29 = 1 or 4: Defines from which motor current onwards there is the normal operation.

Operation

No.	Designation	min.	max.	Default	Unit	r/w	Format	Description
29	Selection of the relay functions at X1	0	5	0		R/W	u16	The normal operation and error relays can be set to special functions if required.
	P29 = 0 means:							the normal operation relay is active when the normal operation frequency is exceeded ($P3 \geq P24 * P25$) the error relay is active in case of an error {TDS/L compatible}
	P29 = 1 means:							the normal operation relay is active when the current falls below the normal operation threshold ($P5 \leq P27$) the error relay is active in case of an error {TDS/L compatible}
	P29 = 2 means:							the normal operation relay controls e.g. a venting valve, activated via the field bus interface (Bit 12 in the control word of the data transfer protocol) the error relay controls e.g. a purge gas valve, activated via the field bus interface (Bit 11 in the control word of the data transfer protocol) (makes only sense at interface operation)
	P29 = 3 means:							the normal operation relay is active when the normal operation frequency is exceeded ($P3 \geq P24 * P25$) the error relay is active when no error exists {T1600 compatible}
	P29 = 4 means:							the normal operation relay is active when the current drops below the normal operation threshold ($P5 \leq P27$) the error relay is active when no error exists
	P29 = 5 means:							the normal operation relay is active in the case of Start and de-energised in the case of Stop, an error or a mains power failure and when the frequency drops below the frequency threshold defined through parameter 247 (Vent function) the error relay is active in case of an error
32	Maximum run up time	P183	2000	*	s	r	u16	Max. permissible time during which the pump must attain the normal operation threshold ($P24 * P25$) with the start signal present.
36	Start delay time	0	255	0	0.1 min	r/w	u16	Delayed starting of the pump in order to allow time for the backing pump.
38	Start counter	0	65535	0		r	u16	Counts the total number of pump run-ups.
40	Error counter total	0	65535	0		r	u16	Counts the total number of error messages output.
41	Error counter overload	0	65535	0		r	u16	Counts of the total number of load limit error messages.
42	Error counter motor							Counts of the total number of pump temperature error messages.
43	Error counter mains supply	0	65535	0		r	u16	Counts the total number of mains power failures.
90	Error mode	0	2	2		r/w	u16	Selection of the error code table saved in P171: 2 = Default setting 1 = Compatible with T1600 0 = Compatible with MagDrive
127	Actual temperature pump housing	0	140	0	°C	r	u16	Measured pump housing temperature.
128	Warning temperature pump housing	0	P132	*	°C	r	u16	When the temperature warning threshold is exceeded, the warning message is output.
132	Limit temperature pump housing	0	140	*	°C	r	u16	Maximum permissible pump housing temperature, $P125 > P132$ will shut the pump down.

No.	Designation	min.	max.	Default	Unit	r/w	Format	Description
171	Error code memory for the 40 most recent events	0	255	0		r	u16	Sequential permanent memory; the individual error codes are accessed via parameter 171 with additional index no. in the parameter order identifier of the interface protocol. The last error code which has occurred is saved at the memory location with the index 0, the oldest is at index 39. See Section n.n for the error codes.
174	Stator frequency at the time of error	0	P18	0	Hz	r	u16	Analogously as for P171 (error code memory)
176	Error operating hours memory for the 40 most recent error events	0	2147483647	0	0.01 h	r	u32	Analogously as for P171 (error code memory)
179	Response when cancelling the control rights or in the case of a communication interruption of the bus adapter	0	65535	0		r/w	u16	

Behaviour in case bit 10 in the control word of the bus adapter is cancelled or when interrupting the communication between converter and bus adapter (see also P182). Here it is assumed that the respective bus adapters perform a cyclic communication on the USS side, so that the respective converter electronics is capable of detecting a communication interruption

The bits in parameter 179 represent an equivalent to the control word in the USS protocol.

The actions linked to these bits are run provided bit 10 in the control word (USS protocol for bus adapter) is cancelled or if there are interruptions in the communication between converter and bus adapter.

Here bit 10 is of special significance:

Bit 10 = 0 The control rights are returned to the next lower priority level. All other bits are not relevant.

Bit 10 = 1 The control rights remain unchanged. The actions linked to the other bits are run.

180	Response delay time	2	19	10	ms	r/w	u16	Pause time between received string and the subsequent reply string (minimum interval)
181	Bus adapter baud rate	48	576	192	100/s	R/W	u16	Baud rate for RS 232/RS 485 options board, respectively internal baud rate for other bus adapter values: 48 = 4800 baud 96 = 9600 baud 192 = 19200 baud (standard) 288 = 28800 baud 576 = 57600 baud

182	Delay when cancelling the control rights of the bus adapter and time-out in the case of a communication interruption	0	65535	10	0.1 s	r/w	u16	
-----	--	---	-------	----	-------	-----	-----	--

Defines the time characteristic when cancelling bit 10 in the control word of the USS protocol or when an interruption in the communication between bus adapter and converter and electronics is detected. Handling when cancelling bit 10 or when there is an interruption on the communication side of the USS bus adapter, is the same.

Value 0.0: Indefinite time delay. In this way a change of the control right is inhibited.

Values 0.1 ..6553.5: A change in the control right corresponding to the setting of parameter 179 is only effected after the time span defined through parameter 182 has elapsed.

Operation

No.	Designation	min.	max.	Default	Unit	r/w	Format	Description
183	Max. passing time	0	P32	500	s	r	u16	Maximum permissible time during which the pump with the start signal present must have passed the critical speed range between 60 Hz and P20.
184	Converter operation hours	0	2147483647	0	0.01 h	r	u32	Sums the operating hours of the converter during active pump operation.
199	Converter factory date	0	20991231	0		r	u32	Converter date of manufacture (YYYYMMDD).
227	Warning bits 1	0	65535	0		r	u16	Active warning, bit-wise representation: Bit 3 = Pump temperature warning (P127 > P128) Bit 11 = Overload warning (P3 < P25*P24 after normal operation has been attained, not evaluated during generator operation) Bit 14 = Power supply voltage warning (P4 > Umax or P4 < Umin or mains power failure)
237	Function normal operation relay on 25-way PLC interface	0	3	2		R/W	u16	0 = Off 1 = On 2 = Normal operation
239	Function optional relay 1	0	2	2		R/W	u16	0 = Off 1 = On 2 = Acceleration (corresponds to bit 4 in the status word)
240	Function optional relay 2	0	5	4		R/W	u16	0 = Off 1 = On 2 = Pump is turning (corresponds to bit 11 in the status word) 3 = Converter is active (corresponds to bit 2 in the status word) 4 = Valve and forevacuum (active for driven pump)
243	Time delay SEMI F47	0	6000	500	0.01 s	r/w	u16	Adjustable time which in the case of an AC voltage breakdown is bridged without an error message. For the entire duration, the converter will indicate a normal operation. Auxiliary parameter for fulfilling SEMI F47 requirements.
247	Power failure "vent on" frequency	P248	P18	300	Hz	R/W	u16	Frequency at which the venting valve shall be switched on in case of a mains power failure. Power failure venting can be enabled through P240.
254	RS 485 address	0	31	0		R/W	u16	Currently valid address at the bus adapter.

No.	Designation	min.	max.	Default	Unit	r/w	Format	Description
303	Actual operating status	0	65535	0		r	u16	Bit 0: Normal operation Bit 1: Ready for switch on Bit 2: Speed is increasing Bit 3: Speed is dropping Bit 4: Generator operation Bit 5: Stand-by Bit 6: reserved Bit 7: reserved
312	Catalogue number (Index 0...10 usable)	0	127	800075V0001		r	u16	P/N of the converter. One ASCII character per index.
313	Product name (Index 0...10 usable)	0	127	TD_CLASSIC		r	u16	Product name of the converter. One ASCII character per index.
315	Serial number converter (Index 0...10 usable)	0	127	0		r	u16	Serial number of the converter. One ASCII character per index.
316	Hardware rev. level	0	65535	0	0.01	r	u16	Hardware version index of the converter.
318	Function optional relay 3	0	1	3		R/W	u16	0 = Off 1 = On 2 = Warning 3 = Fan (active only for driven pump) 4 = Fan (temperature controlled) 5 = Motor current dependent normal operation (active for P5 < 27)
918	Active Profibus address	0	126	0		r	s16	Address set up at the Profibus adapter.
947	Active failure ID	0	55	0		r	s16	Currently present error. See Section 3.2.10 as to the error codes.

3.2.9 Specific parameter data for the pumps

Type of pump	Pump-designation TURBOVAC	Nominal- and setpoint frequency P18, P24	Critical frequency threshold P20	Maximum run-up time P32	Pump housing warning temperature P128	Pump housing shutdown temperature P132
P23						
0	1100 (C)	500	300	720	70	80
1	1000 (C)	600	350	600	70	80
2	600 (C)	600	350	600	70	80
3	361 (C)	750	450	600	55	65
4	151 (C)	833	550	600	55	65

Operation

3.2.10 Error messages

No.	Shutdown	LED	Description	Condition
0	No		No error	
1	No		Overload warning	$P3 < P25 * P24$ (after normal operation has been attained) (not during generator operation!).
3	No		Power supply voltage error	Power supply voltage failure during active pump operation.
4	Yes	5	Converter temperature error	$P11 > \text{limit threshold converter temperature}$.
6	Yes	4	Overload error	$P3 < P20$ after normal operation was attained.
7	Yes	3	Run-up time error	$P3 < P24 * P25$ after P32 has elapsed with start signal being present.
8	Yes	2	Pump error	Pump could not be identified or no pump has been connected.
10	Yes	6	Pump temperature error	$P127 > P132$ or temperature switch = ∞
16	Yes	4	Overload duration error	$P3 < P25 * P24$ longer of than P32.
17	Yes	1	Motor current error	No motor current or motor current too low.
19	Yes	3	Pass-through time error	$60 \text{ Hz} < P3 < P20$ after P183 has elapsed with the start signal being present
43	Yes	8	Internal error	
60	Yes	7	Hardware monitoring (overcurrent, overvoltage)	Short-circuit within the motor or connecting cable
62	No		Pump temperature warning	$P127 > P128$
230 to 251	Yes	7	Internal error	Error within the converter or external voltage applied to the inputs

3.3 Start-up of the TURBOVAC

Press the START key.

The STATUS LED **flashes** during acceleration. The LED chain indicates the increasing speed with one LED each. When 80% of the target speed has been reached, the LED STATUS remains on continuously.

During normal operation the row of LEDs will indicate the amount of power taken up by the TURBOVAC.

3.4 Operation

During NORMAL operation, the LED STATUS lights and the LED chain shows, starting at the bottom and moving upwards, the current consumed.

If the target speed of the TURBOVAC cannot be maintained during normal operation due to overloading (pressure, excessive TURBOVAC or Turbo Drive *classic* temperature), the LED ERROR flashes.

The mode is not a failure, but can result in a shut down depending on the cause of overload, e.g. if the temperature continues to rise.

3.4.1 Status table at default settings

(Parameter 29=0; Normal operation threshold at 80% of the nominal value)

Input data / status				Output data					Operating mode
Start/ stop signal	Pump rotating	Frequency $\geq 80\%$ of setpoint fr.	Error is present	Motor drive	Relay NORMAL OPERATION	Relay ERROR	LED STATUS (green)	LED ERROR (red)	
Stop	no	no	no	off	passive	passive	off	off	Pump not operating
Stop	yes	no	no	off	passive	passive	flashes	off	Pump is decelerating
Stop	yes	yes	no	off	passive	passive	flashes	off	Just after stop; pump was in the normal operating mode before that
Start	no	no	no	on	passive	passive	flashes	off	Just after start
Start	yes	no	no	on	passive	passive	flashes	off	Pump is accelerating
Start	yes	yes	no	on	active	passive	on	off	Pump is in the normal operating mode
Stop	no	no	yes	off	passive	active	off	on	Error is present; pump is at standstill or decelerating
Stop	yes	no	yes	off	passive	active	flashes	on	Error is present; pump is decelerating
Stop	yes	yes	yes	off	passive	active	flashes	on	Error has just occurred
Start	no	no	yes	off	passive	active	off	on	Error is present; pump is at standstill or decelerating
Start	yes	no	yes	off	passive	active	flashes	on	Error is present; pump is decelerating
Start	yes	yes	yes	off	passive	active	flashes	on	Error has just occurred

3.5 Shut-down of the TURBOVAC

Press the STOP key.

While the pump runs down, the STATUS LED flashes. The TURBOVAC runs down until it stands still.

The row of LEDs indicates the decrease in speed through one LED each. The rotational speed can only be indicated down to approximately 250 Hz, i.e. the STATUS LED goes out before the pump has come to a standstill.

Warning



Before working on the pump make sure that the pump is at standstill.

3.6 Shut-down of the Turbo.Drive TD20 *classic*

Press the STOP key.

Set the mains switch on the rear to the position "0".

4 Maintenance

The converter essentially requires no servicing since it contains no components which could be adjusted.

Depending on the installation particulars and the ambient conditions, the converter may collect grime (dust, moisture) on the inside. Such contamination can lead to malfunctions, overheating or short circuits and will have to be avoided to the maximum extent possible. The Leybold Service Department can clean the converter. We recommend adhering to a cleaning interval of about three years.

Warning



Only qualified personnel or the Leybold Service Department may carry out work on the frequency converter.

Potentially fatal voltages are present inside the frequency converter.

Open the frequency converter only after it has been isolated from the mains power supply.

The converter contains components which could be damaged by electrostatic discharges.

5 Troubleshooting

When a malfunction occurs, the TURBOVAC is no longer driven and a failure code is indicated.

The red LED ERROR lights permanently and one green LED within the chain flashes.

After you have eliminated the cause of the failure, you can reset the malfunction signal with the STOP command (key or remote control).

Only qualified personnel or the Leybold Service Department may carry out work on the frequency converter.

Potentially fatal voltages are present inside the frequency converter.

Open the frequency converter only after it has been isolated from the mains power supply.

Warning



Symptom	Probable Cause	Remedy
Turbomolecular pump produces strong running noises and vibrations.	Rotor imbalance. Defective bearing	Have the rotor balanced. Replace the bearing.
Turbomolecular pump does not attain its ultimate pressure.	Defective measuring instrument. Contaminated gauge head. Leak at the apparatus, lines or the pump. Contaminated pump. Inadequate pumping speed of the backing pump or ultimate pressure is too high. Incorrectly programmed frequency parameters.	Check the measuring instrument. Clean or replace the gauge head. Leak search. Clean the pump. Check the ultimate pressure supplied via the backing pump; if required installed a larger backing pump. Check the parameters.
The running pump cannot be stopped through the keys or X1.	The pump was started through the serial interface.	Disconnect the AC supply or provide a serial link and stop through bus.

Troubleshooting

Symptom	Probable Cause	Remedy
LED 1 (left) flashes Line cord fault	Motor connection line incorrectly schlossen connected. Motor connection line malfunctioning.	Check the motor connection line and connect it correctly. Replace the motor connection line.
LED 2 flashes Pump error	Pump could not be identified or no pump has been connected. Frequency converter and pump are not compatible. Connecting cable provides only an intermittent contact.	Check the system. Check the system. Replace the connecting cable.
LED 3 flashes Run-up time error	Forevacuum pressure $>10^{-2}$ mbar. Pump blocked. High vacuum pressure too high.	Check the forevacuum. Inform the Leybold after-sales service. Check the vacuum chamber.
LED 4 flashes Overload error	Forevacuum pressure $>10^{-2}$ mbar. Pump blocked. High vacuum pressure too high.	Check the forevacuum. Inform the Leybold after-sales service. Check the vacuum chamber.
LED 5 flashes Converter temperature error, temperature in the Turbo.Drive TD20 <i>classic</i> is too high.	Frequent switching between acceleration and braking. Ambient temperature too high. Forevacuum pressure $>10^{-2}$ mbar.	Let the Turbo.Drive TD20 <i>classic</i> cool down. Ensure an adequate ventilation. Operate the pump under normal load only.
LED 6 flashes Pump temperature error, temperature in the TURBO-VAC is too high.	Frequent switching between acceleration and braking. Poor cooling or cooling line interrupted.	Let the pump cool down and operate under normal load only. Check the cooling.
LED 7 flashes Internal error	Error during POST.	Inform the Leybold after-sales service.
LED 8 flashes Rotary speed error, speed of the pump does not correspond to the requirements.	Error during POST.	Inform the Leybold after-sales service.
LED 9 is not used.		
Two of the LEDs 1 to 5 flash, TURBO.DRIVE has detected a different pump.	Pump or frequency converter were changed.	Run special acknowledgement, see Chapter Installation.

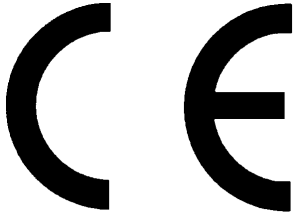

EC Conformance Declaration

We, the Leybold Vacuum GmbH, declare herewith that the products listed below, in the embodiment which we have placed on the market, comply with the applicable EC guidelines.

This declaration becomes invalid if modifications are made to the product without consultation with us.

Designation of the products Frequency converter

Model: **Turbo.Drive TD20 *classic***

The products comply to the following guidelines

- EC Machinery Directive (98/37/EC) and (98/79/EC)
- EC Low-Voltage Equipment Guidelines 73/23/EWG and 93/68/EWG
- EC Directive on Electromagnetic Compatibility
89/336/EWG, 91/263/EWG, 92/31/EWG and 93/68/EWG

Related, harmonized standards

- EN 1012-2: 1996 Compressors and vacuum pumps - Safety requirements - Part 2: Vacuum pumps
- EN 61010 - 1: 2001 Safety requirements for electrical equipment for measurement, control and laboratory use - Part 1: General requirements
- EN 61326: 1997 + A1: 1998 + A2: 2001 + A3: 2003
Electrical equipment for measurement, control, and laboratory use - EMC requirements

Cologne, June 30, 2006

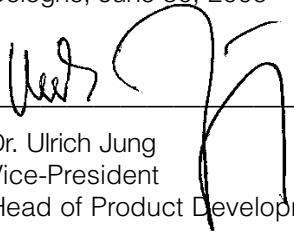

Dr. Ulrich Jung
Vice-President
Head of Product Development

Cologne, June 6, 2006

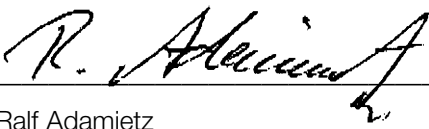

Ralf Adamietz
Head of Design

Leybold Vacuum GmbH
Bonner Strasse 498
D-50968 Cologne
Phone: ++49 (0)221 347-0
Fax: ++49 (0)221 347-1250
documentation@leybold.com

 **Leybold**
vacuum

www.leybold.com

Sales and Service Net Worldwide

Germany

Leybold Vacuum GmbH
Bonner Strasse 498
D-50968 Cologne
Phone: +49-221-347 1234
Fax: +49-221-347 1245
sales@leybold.com

Leybold Vacuum GmbH
Sales Area North/East
Branch office Berlin
Buschkrugallee 33
1. Obergeschoss
D-12359 Berlin
Phone: +49-30-435 609 0
Fax: +49-30-435 609 10
sales.berlin@leybold.com

Leybold Vacuum GmbH
Sales Area South/Southwest
Branch office Munich
Sendlinger Strasse 7
D-80331 Munich
Phone: +49-89-357 33 9-10
Fax: +49-89-357 33 9-33
sales.muenchen@leybold.com
service.muenchen@leybold.com

Leybold Vacuum GmbH
Sales Area West
Branch office Cologne
Bonner Strasse 498
D-50968 Cologne
Phone: +49-221-347 1270
Fax: +49-221-347 1291
sales.koeln@leybold.com

Leybold Vacuum GmbH
Service Center
Emil-Hoffmann-Straße 43
D-50996 Cologne-Suerth
Phone: +49-221-347 1439
Fax: +49-221-347 1945
service@leybold.com

Leybold Vacuum GmbH
Mobile after sales service
Emil-Hoffmann-Straße 43
D-50996 Cologne-Suerth
Phone: +49-221-347 1765
Fax: +49-221-347 1944
kundendienst@leybold.com

Leybold Vacuum GmbH,
Dresden
Zur Wetterwarte 50, Haus 304
D-01109 Dresden
Service:
Phone: +49-351-88 55 00
Fax: +49-351-88 55 041
info@leybold-dresden.de

Europe

Belgium
Leybold Vacuum Nederland B.V.
Belgisch bijkantoor
Leuvensesteenweg 542-9A
B-1930 Zaventem
Sales:
Phone: +32-2-711 00 83
Fax: +32-2-720 83 38
sales.belgium@leybold.com
Service:
Phone: +32-2-711 00 82
Fax: +32-2-720 83 38
service.belgium@leybold.com

France
Leybold Vacuum France S.A.
7, Avenue du Québec
Z.A. de Courtaboeuf 1 - B.P. 42
F-91942 Courtaboeuf Cedex
Sales and Service:
Phone: +33-1-69 82 48 00
Fax: +33-1-69 07 57 38
leybold-vacuum@leybold.fr

Leybold Vacuum France S.A.
Valence Factory
640, Rue A. Bergès - B.P. 107
F-26501 Bourg-lès-Valence Cedex
Phone: +33-4-75 82 33 00
Fax: +33-4-75 82 92 69
marketing.valence@leybold.fr

Great Britain
Leybold Vacuum UK Ltd.
Unit 2
Silverglade Business Park
Leatherhead Road
UK-Chessington Surrey KT9 2QL
Sales:
Phone: +44-13-7273 7300
Fax: +44-13-7273 7301
sales.uk@leybold.com
Service:
Phone: +44-20-8971 7030
Fax: +44-20-8971 7003
service.uk@leybold.com

Italy
Leybold Vacuum Italia S.p.A.
8, Via Trasimeno
I-20128 Milano
Sales:
Phone: +39-02-27 22 31
Fax: +39-02-27 20 96 41
sales@leybold.it
Service:
Phone: +39-02-27 22 31
Fax: +39-02-27 22 32 17
service@leybold.it

Leybold Vacuum Italia S.p.A.
Field Service Base
Z.I. Le Capanne
I-05021 Acquasparta (TR)
Phone: +39-0744-93 03 93
Fax: +39-0744-94 42 87
service@leybold.it

Netherlands
Leybold Vacuum Nederland B.V.
Computerweg 7
NL-3542 DP Utrecht
Sales and Service:
Phone: +31-346-58 39 99
Fax: +31-346-58 39 90
sales.netherlands@leybold.com
service.netherlands@leybold.com

Spain
Leybold Vacuum Spain, S.A.
C/ J. Huelva, 7
E-08940 Cornellà de Llobregat
(Barcelona)
Sales:
Phone: +34-93-666 46 16
Fax: +34-93-666 43 70
sales.spain@leybold.com
Service:
Phone: +34-93-666 49 51
Fax: +34-93-685 40 10

Sweden
Leybold Vacuum Scandinavia AB
Box 9084
SE-40092 Göteborg
Sales and Service:
Phone: +46-31-68 84 70
Fax: +46-31-68 39 39
info@leybold.se
Visiting/delivery address:
Datavägen 57B
SE-43632 Askim

Switzerland
Leybold Vacuum Schweiz AG
Leutschenbachstrasse 55
CH-8050 Zürich
Sales:
Phone: +41-044-308 40 50
Fax: +41-044-302 43 73
sales@leybold.ch
Service:
Phone: +41-044-308 40 62
Fax: +41-044-308 40 60

America

USA
Leybold Vacuum USA Inc.
5700 Mellon Road
Export, PA 15632
Sales and Service:
Phone: +1-724-327-5700
Fax: +1-724-325-3577
info@leyboldvacuum.com

Asia

P.R. China
Leybold Vacuum (Tianjin)
International Trade Co., Ltd.
Beichen Economic
Development Area (BEDA),
Shanghai Road
Tianjin 300400
China
Sales and Service:
Phone: +86-22-2697 0808
Fax: +86-22-2697 4061
Fax: +86-22-2697 2017
sales.china@leybold.com

Leybold Vacuum (Tianjin)
Equipment Manufacturing Co., Ltd.
Beichen Economic
Development Area (BEDA),
Shanghai Road
Tianjin 300400
China
Sales and Service:
Phone: +86-22-2697 0808
Fax: +86-22-2697 4061
Fax: +86-22-2697 2017
info.tianjin@leybold.com

Leybold Vacuum (Tianjin)
International Trade Co., Ltd.
Shanghai Branch:
Add: No. 33
76 Futedong San Rd.
Waigaoqiao FTZ
Shanghai 200131
China
Sales and Service:
Phone: +86-21-5064-4666
Fax: +86-21-5064-4668
info.shanghai@leybold.com

Leybold Vacuum (Tianjin)
Guangzhou Branch:
Add: G/F,#301 Building
110 Dongguangzhuang Rd.
Tianhe District
Guangzhou 510610
China
Sales:
Phone: +86-20-8723-7873
Phone: +86-20-8723-7597
Fax: +86-20-8723-7875
info.guangzhou@leybold.com

Leybold Vacuum (Tianjin)
International Trade Co., Ltd.
Beijing Branch:
1-908, Beijing Landmark Towers
8 North Dongsanhuan Road
Chaoyang District
Beijing 100004
China
Sales:
Phone: +86-10-6590-7607
Fax: +86-10-6590-7622

India
Leybold Vacuum India Pvt Ltd.
EL-22, J Block
MIDC Bhosari
Pune 411026
India
Sales:
Phone: +91-20-3061 60000
Fax: +91-20-2712 1571
sales.india@leybold.com

Japan
Leybold Vacuum
Japan Co., Ltd.
Head Office
Tobu A.K. Bldg. 4th Floor
23-3, Shin-Yokohama
3-chome
Kohoku-ku, Yokohama-shi
Kanagawa-ken 222-0033
Sales:
Phone: +81-45-471-3330
Fax: +81-45-471-3323
webmaster@leybold.co.jp

Leybold Vacuum
Japan Co., Ltd.
Osaka Branch Office
MARUTA Bldg. 7F
2-7-53, Nishi-Miyahara
Yodogawa-ku
Osaka-shi 532-0004
Sales:
Phone: +81-6-6393-5211
Fax: +81-6-6393-5215
webmaster@leybold.co.jp

Leybold Vacuum
Japan Co., Ltd.
Tsukuba Technical S.C.
Tsukuba Minami Daiichi
Kogyo Danchi
21, Kasumi-no-Sato,
Ami-machi, Inashiki-gun
Ibaraki-ken, 300-0315
Service:
Phone: +81-29-889-2841
Fax: +81-29-889-2838
webmaster@leybold.co.jp

Korea
Leybold Vacuum Korea Ltd.
#761-4, Yulkeum-ri
SungHwan-eup, Cheonan-City
Choongchung-Namdo
330-807 Korea
Sales:
Phone: +82-41-580-4420
Fax: +82-41-588-3737
Service:
Phone: +82-41-580-4415
Fax: +82-41-588-3737

Singapore
Leybold Vacuum
Singapore Pte Ltd.
No.1, International
Business Park,
B1-20B, The Synergy
Singapore 609917
Sales and Service:
Phone: +65-6665 2910
Fax: +65-6566 8202
vacuum@leyboldvac.com.sg

Taiwan
Leybold Vacuum Taiwan Ltd.
No 416-1, Sec. 3
Chung-Hsin Rd., Chu-Tung
Hsin-Chu, Taiwan, R.O.C.
Sales and Service:
Phone: +886-3-5833 988
Fax: +886-3-5833 999
sales@leyboldvacuum.com.tw

Hotline
Sales: +49-221-347 1234
Service: +49-221-347 1765
sales@leybold.com
service@leybold.com

Leybold Vacuum USA Inc.
5700 Mellon Road
Export, PA. 15632
Phone: 724-327-5700
Fax: 724-325-3577
info@leyboldvacuum.com

Leybold Vacuum GmbH
Bonner Strasse 498
D-50968 Cologne
Phone: +49-221 347-0
Fax: +49-221 347-1250
info@leybold.com

Leybold
vacuum

www.leybold.com