

OPERATING INSTRUCTIONS



TURBOVAC

Turbomolecular pumps with
grease-lubricated bearings

TURBOVAC 35 LS, 35 LS2

TURBOVAC 50

TURBOVAC 151, 151 C

TURBOVAC 361, 361 C

TURBOVAC 600 C

TURBOVAC 1000 C

and pumps modified by Leybold

Contents

Section		Page
	Important Safety Information	3
1	Description	6
1.1	Design and Operation	6
1.2	Supplied Equipment	6
1.3	Technical Data.	7
1.4	Ordering Information	12
1.5	Operating environment and cooling.	13
2	Transport and Storing	14
3	Installation	15
3.1	Conforming Utilisation	15
3.2	Ambient Conditions.	15
3.3	Connecting the pump to the vacuum chamber.	16
3.4	Forevacuum connection	20
3.5	Connecting the cooling	20
3.6	Connecting the purge gas and airing device	22
3.7	Connecting the TURBOTRONIK	23
4	Operation	24
4.1	Media Compatibility/Purge Gases	24
4.2	Start-up	25
4.3	Bakeout	26
4.4	Operation	26
4.5	Switching Off.	26
4.6	Venting	27
5	Maintenance	29
5.1	Maintenance Intervals	29
5.2	Leybold Service.	29
5.3	Cleaning	30
5.4	Removing the pump from the system	30
6	Troubleshooting	31
7	Waste Disposal	33
	EC Manufacturer's Declaration	34

Important Safety Information

Indicates procedures that must be strictly observed to prevent hazards to persons.

Warning

Indicates procedures that must be strictly observed to prevent damage to, or destruction of the product.

Caution

The Leybold TURBOVAC has been designed for safe and efficient operation when used properly and in accordance with these Operating Instructions. It is the responsibility of the user to carefully read and strictly observe all safety precautions described in this section and throughout the Operating Instructions. The TURBOVAC **must only be operated in the proper condition and under the conditions described in the Operating Instructions**. It must be operated and maintained by trained personnel only. Consult local, state, and national agencies regarding specific requirements and regulations. Address any further safety, operation and/or maintenance questions to your nearest Leybold Vacuum office.



Failure to observe the following precautions could result in serious personal injury!

Mechanical hazards

Risk of injury!

Avoid exposing any part of the human body to the vacuum. Only handle the pump when it is vented.

Warning



Turbopumps as described in the following operation manual contains a high portion of kinetic energy due to their high rotational speed in combination with the specific rotor mass.

In case of a malfunction of the system for example rotor/stator contact or even a rotor crash the rotational energy is released.

Warning



To avoid the destruction of the equipment and to prevent injuries of the operating staff the leading European manufacturers of vacuum pumps strictly recommend to follow the installation instructions as given in this manual!

Never operate the pump (in bench tests, for instance) without its being flanged to the vacuum chamber.

The small-flange connector for the high-vacuum flange at the TURBOVAC 50 is not strong enough to keep the pump from rotating if it should suddenly seize. Rotation of the pump can cause leaks in the forevacuum line.

Secure the pump additionally to prevent rotation in case it should suddenly seize.

Safety Information

Electrical hazards

Warning



Risk of injury!

Dangerous voltages are present at the mains connections. Before beginning with any maintenance or service work on the pump, disconnect the pump from all power supplies.

Operate the pump only with the matching frequency converter and connector line.

Voltages of up to 400 V will be present at the connection cable between the frequency converter and the pump; mains voltage will be present at the fan, the flange heater, the valves and their supply leads.

Route the conductors and cables so as to protect them from damage.

When the connector cable to the TURBOVAC is attached, the outputs of the TURBOTRONIK frequency converter are not free of voltage.

Thermal hazards

Warning



Risk of injury!

The pump can become so hot during operation (> 70°C, 158 °F) as to represent a burn hazard. Shield the hot components against contact.

Note the symbols on the pump pointing to the hazards, and in the case of a hot pump wear the required protective clothing.

Hazards caused by materials and substances

Warning



The forevacuum line must be tight.

Hazardous gases could escape from leaks or the gases being pumped could react with air or humidity.

Take the appropriate precautionary measures prior to opening the intake or discharge connection if the pump has previously handled hazardous gases.

If necessary, use gloves, a respirator and/or protective clothing and work under an exhaust hood.

Risk of explosion!

The standard version of the pump is **not suited** for operation in **explosion hazard areas**. Contact us before planning to use the pump under such circumstances.

Contaminated parts can be detrimental to health and environment. Before beginning with any work, first find out whether any parts are contaminated. Adhere to the relevant regulations and take the necessary precautions when handling contaminated parts.



Failure to observe the following precautions could result in damage to the pump!

Unauthorized opening of the pump or modifications of the mechanical or electrical components of the pump void the warranty.

The pump must only be opened by such persons who have been authorised by Leybold to do so.

The rotor is precision balanced; any change whatsoever, such as loosening or bending any rotor component, will make re-balancing necessary.

Unless appropriate accessories and attachments are used, the TURBOVAC **is not** suitable for aggressive or corrosive media, or those containing dust. When handling corrosive media the C version pump must be operated with purge gas; when handling media containing dust, a fine-mesh filter must be installed.

Observe the information on media compatibility, to be found in Section 4.1.

Take care not to damage the plugs and coolant connections during movement.

Exposure of the pump to accelerating forces must be avoided or reduced to such an extent that the rotor unit will not be excited by vibrations. In the case of critical applications you must consult our Applications Dept. first.

Caution

The references to diagrams, e. g. (1/2) consist of the Fig. No. and the Item No. in that order.

We reserve the right to alter the design or any data given in these Operating Instructions. The illustrations are not binding.

Retain the Operating Instructions for further use.

Figures

1 Description

1.1 Design and Operation

The TURBOVAC models 35 LS to 1000 are turbomolecular pumps featuring grease-lubricated bearings. These units are engineered to pump vacuum chambers down to pressures in the high-vacuum range. A TURBOTRONIK frequency converter and a forevacuum pump are required for the operation of the TURBOVAC.

1.2 Supplied Equipment

The TURBOVAC is shipped in a sealed PE bag which also contains a desiccant. The maximum effective life of the desiccant is one year.

TURBOVAC 35 LS / 35 LS2

The pumps are shipped without splinter guard or connection accessories.

TURBOVAC 50 to 1000

For high-vacuum port with ISO-K flange:

Splinter guard, centering ring with FPM sealing ring; outer ring.

For high-vacuum port with CF flange: Splinter guard.

For high-vacuum port with KF flange: Splinter guard, centering ring with FPM O-ring and clamping ring.

For high-vacuum port with ANSI flange: Splinter guard.

Forevacuum port: Centering ring with O-ring and clamping ring.

Both the purge gas port and the airing port are blanked off for shipping.

In addition the pivoted threaded fittings used to make the coolant connection are included as standard equipment for the TURBOVAC 151, 361 and 600; if needed, they can be used to replace the hose nipples installed at the factory.

The electronic frequency converter and the connector cables required for operation are not included as standard equipment with the pump.

PE = Polyethylene

FPM = Fluoroelastomer, resistant to temperatures of up to 150°C (300 °F)

1.3 Technical Data

TURBOVAC 35 LS / 35 LS2

TURBOVAC		35 LS	35 LS2
High-vacuum port	DN	40 KF	40 KF
Pumping speed			
He, high vacuum	$l \cdot s^{-1}$	25	32
He, interstage vacuum	$l \cdot s^{-1}$	4.5	5.5
Max. gas throughput in permanent operation with water cooling at 10^{-2} mbar,			
He	$mbar \cdot l \cdot s^{-1}$	0.25	0.25
Max. idle compression			
He, high vacuum		$1.5 \cdot 10^3$	$2 \cdot 10^4$
He, interstage vacuum		70	600
Max. forevacuum pressure for He	mbar	1	6
Forevacuum port	DN	16 KF	16 KF
Recommended forevacuum pump		TRIVAC D 2,5 E	Diaphragm pump
Run-up time to 95% nominal speed	min		2
Weight, approx.	kg		2
Max. power consumption / at ultimate pressure	W		45 / 15
Max. ambient temperature at operation	°C		45

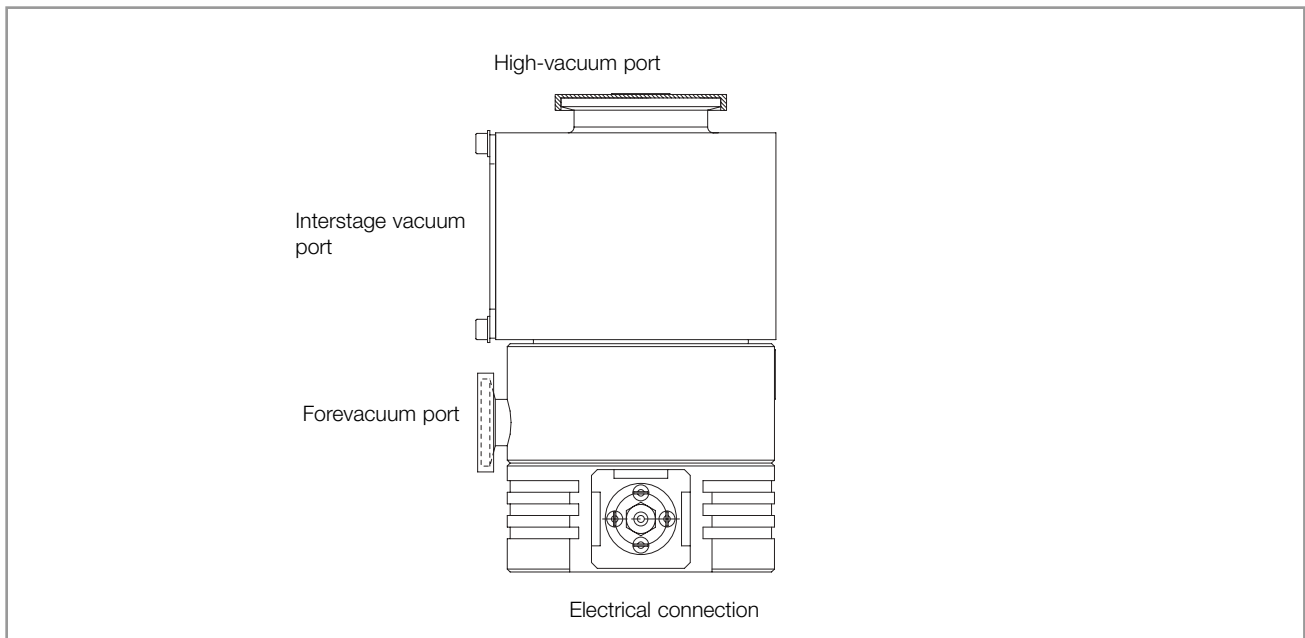

TURBOVAC 35 LS and 35 LS2

Description

TURBOVAC 50

		O-Ring sealed 40 KF	O-Ring sealed 63 ISO-K	Metal sealed 63 CF
High-vacuum port	DN			
Pump housing		Aluminium	Aluminium	Stainless steel
Pumping speed at 10^{-3} mbar				
N ₂	$l \cdot s^{-1}$	33	55	55
He	$l \cdot s^{-1}$	36	48	48
H ₂	$l \cdot s^{-1}$	28	30	30
Max. gas throughput in permanent operation with water cooling at 10^{-2} mbar				
N ₂	$mbar \cdot l \cdot s^{-1}$	0.30	0.40	0.40
He	$mbar \cdot l \cdot s^{-1}$	0.25	0.35	0.35
H ₂	$mbar \cdot l \cdot s^{-1}$	0.20	0.25	0.25
Max. idle compression N ₂		$2 \cdot 10^6$	$2 \cdot 10^6$	$2 \cdot 10^8$
Ultimate pressure with TRIVAC D 2,5 E	mbar	$< 5 \cdot 10^{-8}$	$< 5 \cdot 10^{-8}$	$< 2 \cdot 10^{-10}$
Max. forevacuum pressure for N ₂	mbar		$1 \cdot 10^{-1}$	
Forevacuum port	DN		16 KF	
Recommended forevacuum pump			TRIVAC D 2,5 E	
Run-up time to 95% nominal speed	min		2	
Cooling water connection (hose nozzle) (for Part No. 854 08)	mm		10	
Weight, approx.	kg		2	
Max. power consumption / at ultimate pressure W			45 / 15	
Max. ambient temperature at operation	°C		55	
Max. bakeout temperature at CF flange	°C		80	

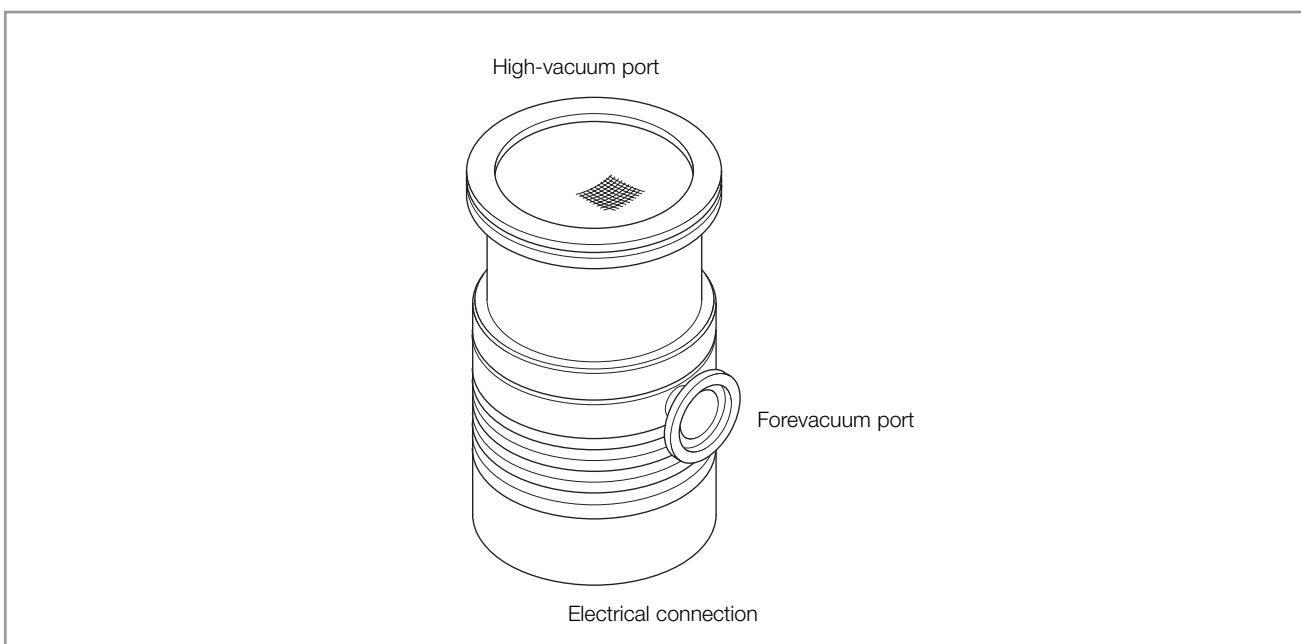

TURBOVAC 50

TURBOVAC 151 TURBOVAC 361 / 361 C

High-vacuum port		DN	100 ISO-K / 100 CF	100 ISO-K • 100 CF	160 ISO-K • 160 CF	
Pumping speed	N ₂		l · s ⁻¹	145	345	400
	Ar		l · s ⁻¹	150	350	–
	He		l · s ⁻¹	135	340	380
	H ₂		l · s ⁻¹	115	340	370
Max. gas throughput	N ₂	mbar · l · s ⁻¹		3	7.5	–
	Ar	mbar · l · s ⁻¹		3	7.5	–
	H ₂	mbar · l · s ⁻¹		1.7		
Compression	N ₂			1 · 10 ⁹	1 · 10 ⁹	
	He			2 · 10 ⁴	6 · 10 ⁴	
	H ₂			8 · 10 ²	3 · 10 ³	
Ultimate pressure		mbar		< 1 · 10 ⁻¹⁰	< 1 · 10 ⁻¹⁰	
Max. Inlet pressure (permanent) with water cooling		mbar		5 · 10 ⁻²	5 · 10 ⁻²	
Max. forevacuum pressure for N ₂		mbar		5 · 10 ⁻¹	5 · 10 ⁻¹	
Recommended forevacuum pump		TRIVAC		D 4 B to D 16 B	D 16 B to D 25 B	
Run-up time to 95% nominal speed		min		≈ 2	≈ 2	
Forevacuum port		DN		25 KF	25 KF	
Purge gas / vent port		DN		10 KF	10 KF	
Cooling water connection (hose nozzle)		mm		10	10	
Weight, approx.		kg		8	12	
Max. power consumption / at ultimate pressure VA				680 / 480	680 / 480	
Max. ambient temperature at operation		°C		55	55	
Max. bakeout temperature at CF flange		°C		100	100	

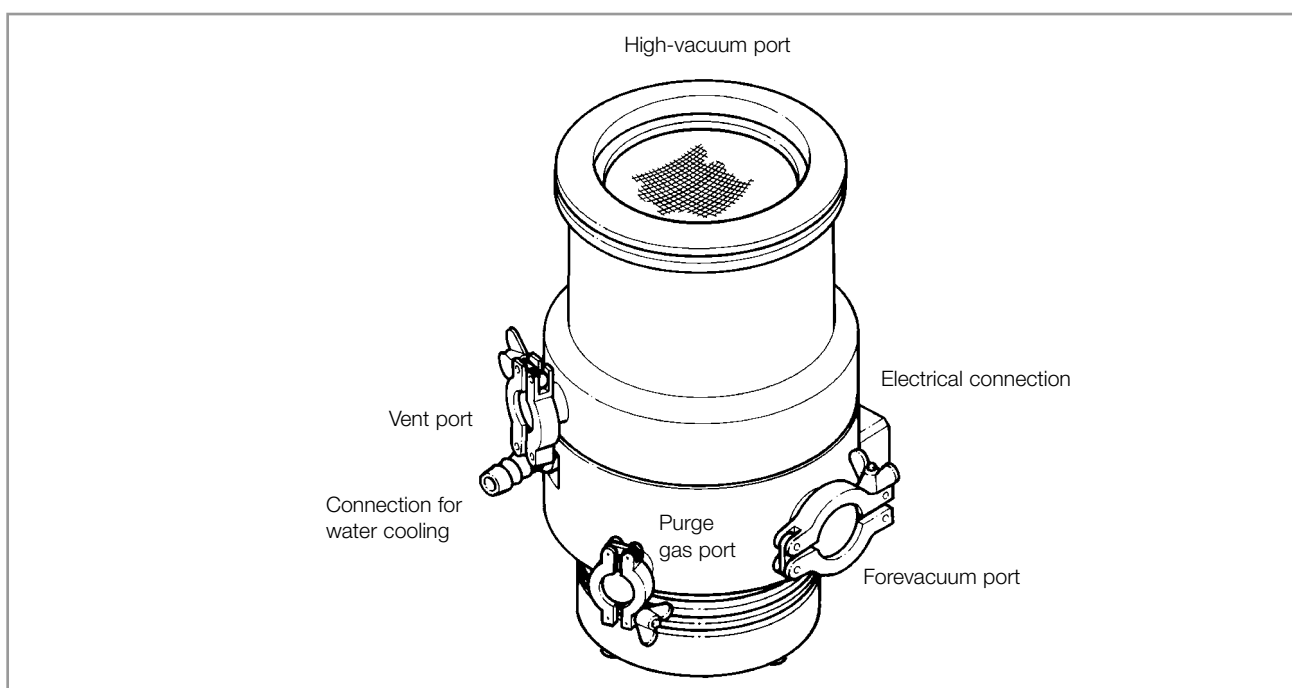

TURBOVAC 151 C; TURBOVAC 361 C similar

Description

TURBOVAC 600 C

TURBOVAC 1000 C

High-vacuum port	DN	160 ISO-K • 160 CF		160 ISO-K/CF	200 CF/6" ANSI	250 ISO-K
Pumping speed	N ₂	l · s ⁻¹	560	850	1100	1150
	He	l · s ⁻¹	600	-	-	-
	H ₂	l · s ⁻¹	570	-	-	-
Max. gas throughput	N ₂	mbar · l · s ⁻¹	< 4		-	
	Ar	mbar · l · s ⁻¹	< 4		-	
Compression	N ₂		> 10 ⁹		-	
	He		2 · 10 ⁴		-	
	H ₂		1.1 · 10 ³		-	
Ultimate pressure		mbar	< 10 ⁻¹⁰		< 10 ⁻¹⁰	
Speed		rpm	36,000		36,000	
Run-up time (freq. converter), approx.		min	4		9	
Max. Inlet pressure (permanent) with water cooling		mbar	1 · 10 ⁻²		-	
Max. forevacuum pressure for N ₂		mbar	1 · 10 ⁻¹		10 ⁻³ to 10 ⁻²	
Recommended forevacuum pump	at standard operation	TRIVAC	D 25 B / 40 B		TRIVAC D 40 B	
	at purge gas operation	TRIVAC	40 B			
Run-up time to 95% nominal speed		min	3		-	
Forevacuum port	DN		40 KF	40 KF/63 ISO-K	40 KF	40 KF/63 ISO-K
Purge gas / vent port	DN		10 KF	10 KF ¹⁾	10 KF ¹⁾	10 KF ¹⁾
Cooling water connection (hose nozzle)	mm		10	11 / 10 ²⁾	11	11 / 10 ²⁾
Weight, approx.		kg	12		25	
Max. power consumption / at ultimate pressure VA			680 / 480		-	
Max. ambient temperature at operation		°C	55		55	
Max. bakeout temperature at CF flange		°C	100		100	

1) As of 1995 in some cases 16 mm KF

2) 11 mm with 40 mm type KF forevacuum port
10 mm with 63 mm type ISO-K forevacuum port

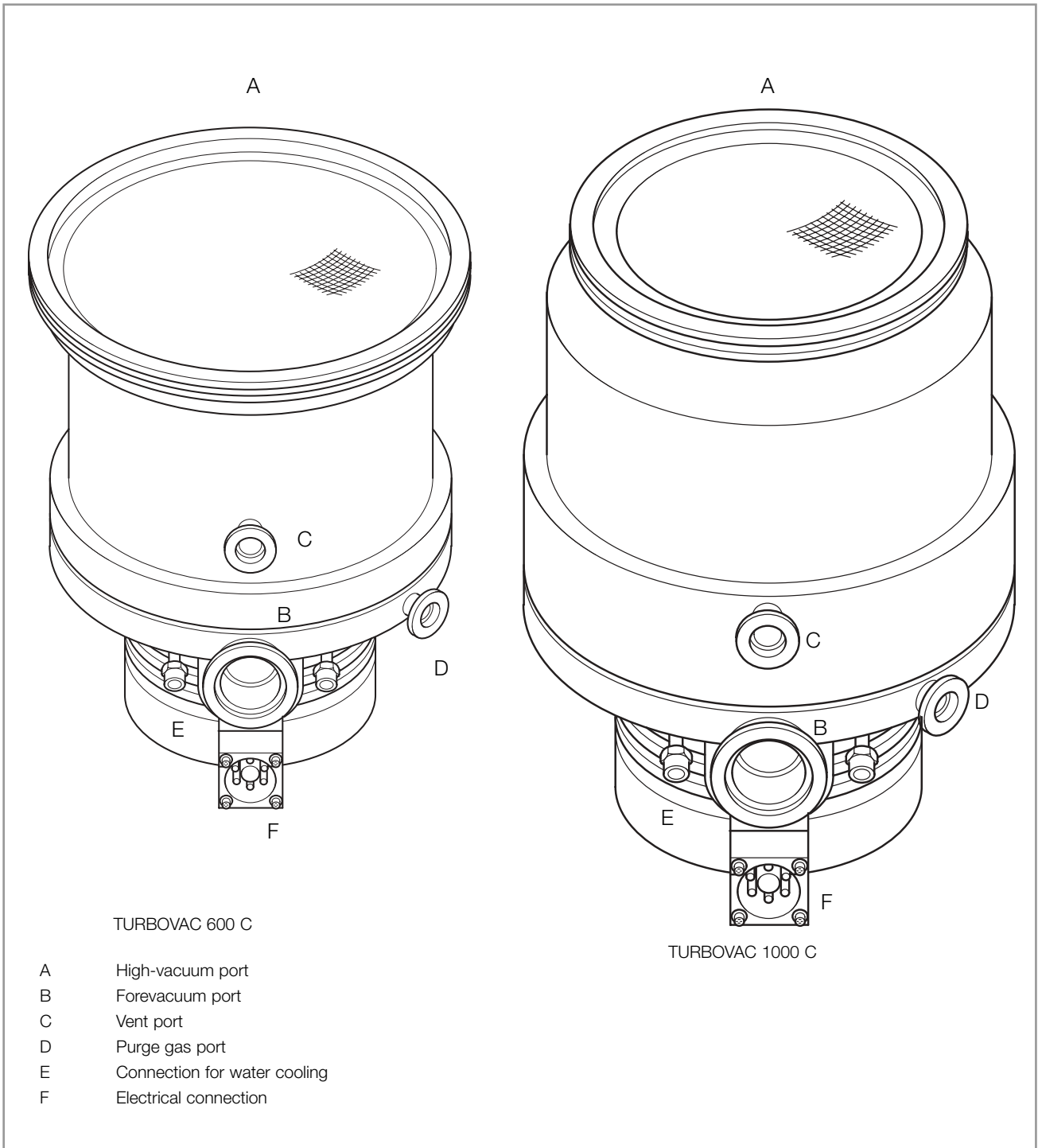

Fig. 2

Description

1.4 Ordering Information

TURBOVAC 35 LS 35 LS 2 50 151 151 C 361 361 C 600 C 1000 C

High-vacuum port

DN 40 KF	856 64	856 66	854 00						
DN 40 CF			853 99						
DN 63 ISO-K			854 01 800150V0010						
DN 63 CF			854 02						
DN 100 ISO-K				856 31	856 35	856 70	856 75		
DN 100 CF				856 32		856 71			
DN 160 ISO-K						856 72	856 77	800150V0015	855 35 ¹⁾ 855 38 ²⁾
DN 160 CF						856 73		800150V0017	on request
DN 200 CF									on request
6" ANSI									894 89 ¹⁾
DN 250 ISO-K									855 36 ¹⁾ 855 37 ¹⁾ 855 39 ²⁾
Cooling water unit for TURBOVAC 35 LS, 35 LS2, 50			854 08						

1) With forevacuum flange DN 40 KF

2) With forevacuum flange DN 63 ISO-K

1.5 Operating environment and cooling

TURBOVAC	No additional cooling required if all these conditions are satisfied	Air or water cooling required	Water cooling required if any one of these conditions prevails
35 LS 35 LS2	Ambient temperature < 30° C No bakeout operations High-vacuum pressure < 10 ⁻³ mbar Forevacuum pressure < 5·10 ⁻¹ mbar	Ambient temperature 30 - 40 °C Bakeout operations High-vacuum pressure 10 ⁻³ to 5·10 ⁻² mbar Forevacuum pressure 5·10 ⁻¹ to 2 mbar	Ambient temperature 40 - 45 °C Bakeout operations High-vacuum pressure > 5·10 ⁻² mbar Forevacuum pressure > 2 mbar
50	Continuous operation at high-vacuum pressure < 10 ⁻⁴ mbar Ambient temperature < 45 °C	Bakeout at ambient temperature < 40 °C Continuous operation at high-vacuum pressure > 10 ⁻⁴ mbar Rapid-cycling operation	Ambient temperature 45 - 55 °C Bakeout at ambient temperature > 40° C
151, 151 C, 361, 361 C	—	Bakeout at ambient temperature < 35 °C or High-vacuum pressure < 10 ⁻³ mbar and ambient temperature < 45 °C	Bakeout at ambient temperature > 35 °C High-vacuum pressure > 10 ⁻³ mbar Ambient temperature 45 - 55 °C
600 C	—	Bakeout at ambient temperature < 35 °C or high-vacuum pressure < 10 ⁻³ mbar and ambient temperature < 45 °C	Bakeout at ambient temperature > 35 °C High-vacuum pressure > 10 ⁻³ mbar Ambient temperature 45 - 55 °C
1000 C	—	Bakeout at ambient temperature < 35° C or high-vacuum pressure < 10 ⁻⁴ mbar and ambient temperature < 45 °C	Bakeout at ambient temperature > 35 °C High-vacuum pressure > 10 ⁻⁴ mbar Ambient temperature 45 - 55 °C

°C	°F	mbar	Torr
30	86	10 ⁻⁴	8·10 ⁻⁵
35	95	10 ⁻³	8·10 ⁻⁴
40	104	10 ⁻²	8·10 ⁻³
45	113	5·10 ⁻²	4·10 ⁻²
50	122	5·10 ⁻¹	4·10 ⁻¹
55	131	2	1.5

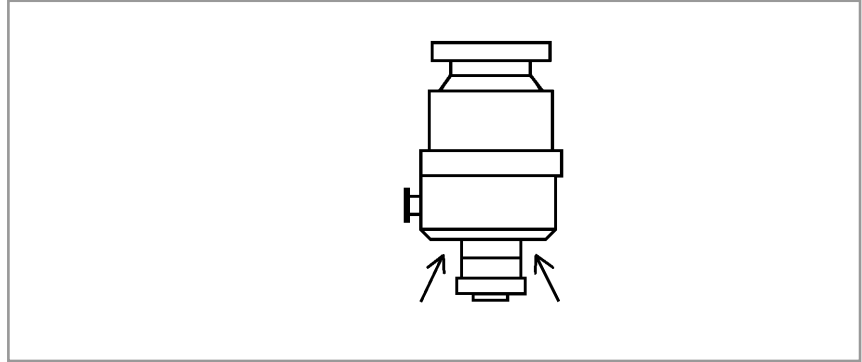

Fig. 3 Transportation

2 Transport and Storing

When moving the heavier pumps, the lower surfaces on the base flange are suitable for accepting a lifting fork; see Fig. 3.

Caution Take care not to damage the plugs and coolant connections during movement.

The TURBOVAC is shipped in a sealed PE bag which also contains a desiccant. The maximum effective life of the desiccant is one year.

Do not open the packaging until immediately prior to installation.

3 Installation

3.1 Conforming Utilisation

The TURBOVAC models are engineered to pump vacuum chambers down to pressures in the high-vacuum range. A TURBOTRONIK frequency converter and a forevacuum pump are required for the operation of the TURBOVAC.

The TURBOVAC 35 LS and 35 LS2 are only intended for integration into a Helium leak detector.

These units are **not** suitable for operation without a forevacuum pump.

Turbomolecular pumps are **not** suitable for pumping either gases which contain dust particles or liquids.

Turbomolecular pumps without a purge gas feature are suitable only for moving air or inert gases. They are not suitable for pumping aggressive or reactive gases.

TURBOVAC versions identified with a "C" in the model number are equipped with this purge gas feature, it protects only the bearing area and the motor in the TURBOVAC.

3.2 Ambient Conditions

When using the TURBOVAC inside a magnetic field, the magnetic induction at the pump housing surface may not exceed the following values:

Magnetic field

TURBOVAC 50: $B = 7 \text{ mT}$

TURBOVAC 151 – 1000:

$B = 5 \text{ mT}$ in case of radial impingement

$B = 15 \text{ mT}$ in case of axial impingement

Provide suitable shielding measures if these values are exceeded.

The standard version is resistant to radiation at levels up to 10^3 Gy .

1 mT (milliTesla) = 10 G (Gauss)

1 Gy (Gray) = 100 rad

3.3 Connecting the pump to the vacuum chamber

Remove the covers and the blank flanges at the turbomolecular pump only just before installing, to ensure that the TURBOVAC is installed under the cleanest possible conditions.

Do not stand below the TURBOVAC pump while it is being connected to or detached from the system.

Warning



Turbopumps as described in the following operation manual contains a high portion of kinetic energy due to their high rotational speed in combination with the specific rotor mass.

In case of a malfunction of the system for example rotor/stator contact or even a rotor crash the rotational energy is released.

To avoid the destruction of the equipment and to prevent injuries of the operating staff the leading European manufacturers of vacuum pumps strictly recommend to follow the installation instructions as given in this manual!

The high-vacuum flange must be securely attached to the vacuum chamber. If the pump were to become blocked, insufficient attachment could cause the pump to break away from its mount or allow internal pump parts to be discharged. Never operate the pump (in bench tests, for instance) without its being flanged to the vacuum chamber.

If the pump should suddenly seize, the ensuing deceleration torque will have to be absorbed by the system. To accomplish this, the following are required when securing an ISO-K type high-vacuum flange:

TURBOVAC	Braking torque [Nm]	Clamping bolts
35 LS / LS2	150	4
50	63	4
151/151 C	283	4
361/361 C	580	6
600 C	1486	10
1000 C DN 160	1500	16
DN 250	1500	10

Clamping bolts made of steel must be torqued down to 35 Nm, those of quality 12.9 to 50 Nm.

When installing CF flanges, use only the bolts specified (tightening torque is 15 Nm for DN 40 CF, 30 Nm for DN 63 CF and larger).

You will find the order numbers for the (clamping) bolts in the Leybold Catalog.

The clamping bolts are **not** included as standard equipment with the pump.

Nm	15	30	35	50
ft-lb	11	22	26	37

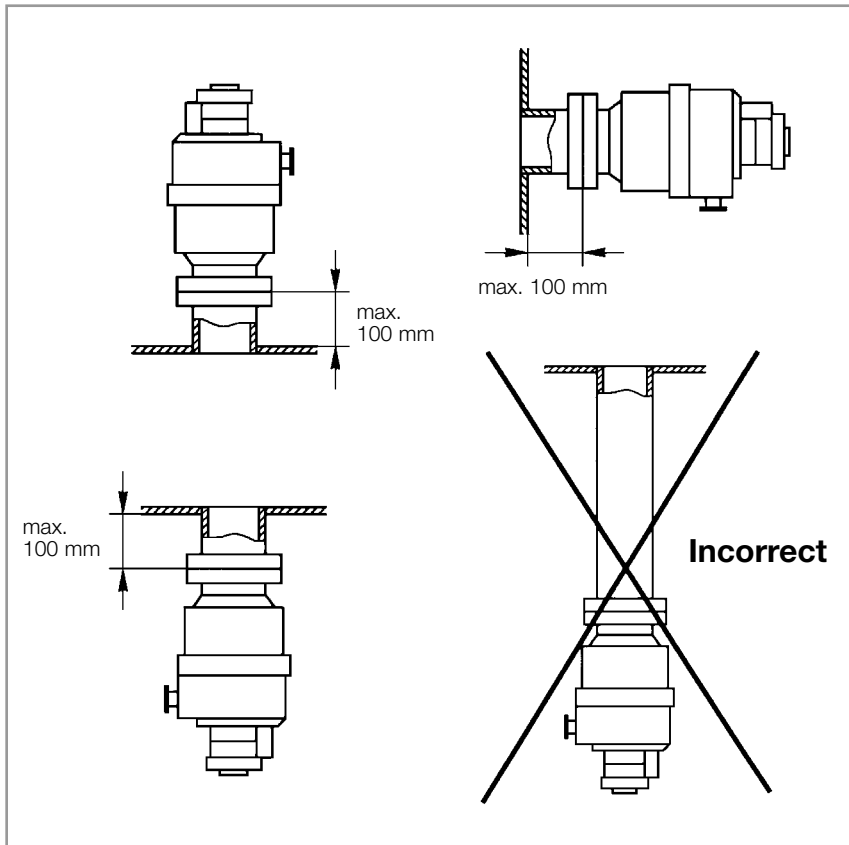

Fig. 4 Fixed flanging of the TURBOVAC to the vacuum chamber

The small-flange connector for the high-vacuum flange at the TURBOVAC 50 is not strong enough to keep the pump from rotating if it should suddenly seize. Rotation of the pump can cause leaks in the forevacuum line.

Secure the pump additionally to prevent rotation in case it should suddenly seize.

Warning



In most applications the TURBOVAC will be flanged direct to the high-vacuum flange for the system. The design of the lubricating system makes it possible to mount and run the TURBOVAC in any desired attitude. It is not necessary to support the pump.

If there is a danger that dust could pass from the vacuum chamber into the TURBOVAC, install a fine-mesh filter between the vacuum chamber and the TURBOVAC.

Fine-mesh filter

The TURBOVAC is precision balanced and is generally operated without a vibration damper. A special-design vibration damper is available for mounting at the TURBOVAC high-vacuum flange to decouple extremely sensitive equipment and to prevent external vibrations from being transferred to the TURBOVAC. If the TURBOVAC 1000 C are flanged via a vibration damper secure it in addition at the base flange.

Vibration damper

Installation

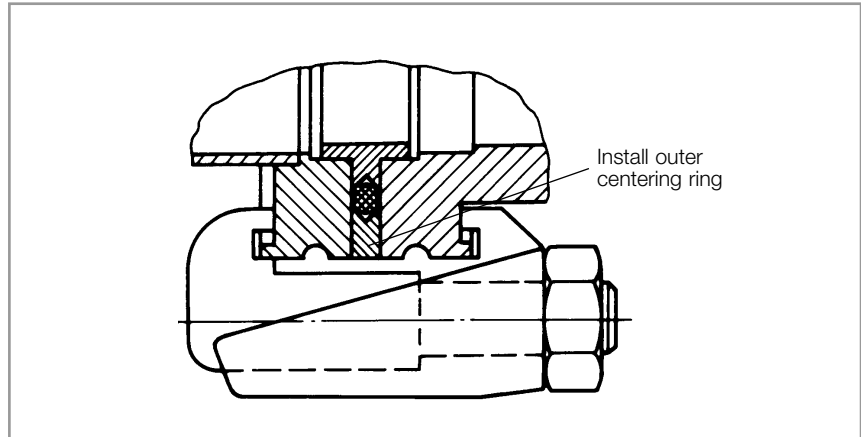

Fig. 5 Using ISO-K flanges

Design with ISO-K clamp flange

Fit the O-ring at the centering ring.

The O-ring should be flat and even; it must not be twisted. Then add the outer ring.

A collar flange with retaining ring and suitable sealing washer can also be used to connect the TURBOVAC.

A collar flange is required when using ultra-high-vacuum sealing washers.

Splinter guard

A splinter guard is installed in the high-vacuum flange to protect the TURBOVAC.

Operate the pump only with this splinter guard in place as foreign objects passing through the intake port and into the pump can cause serious damage to the rotor. Damage caused by foreign objects in the rotor section is excluded from the guarantee.

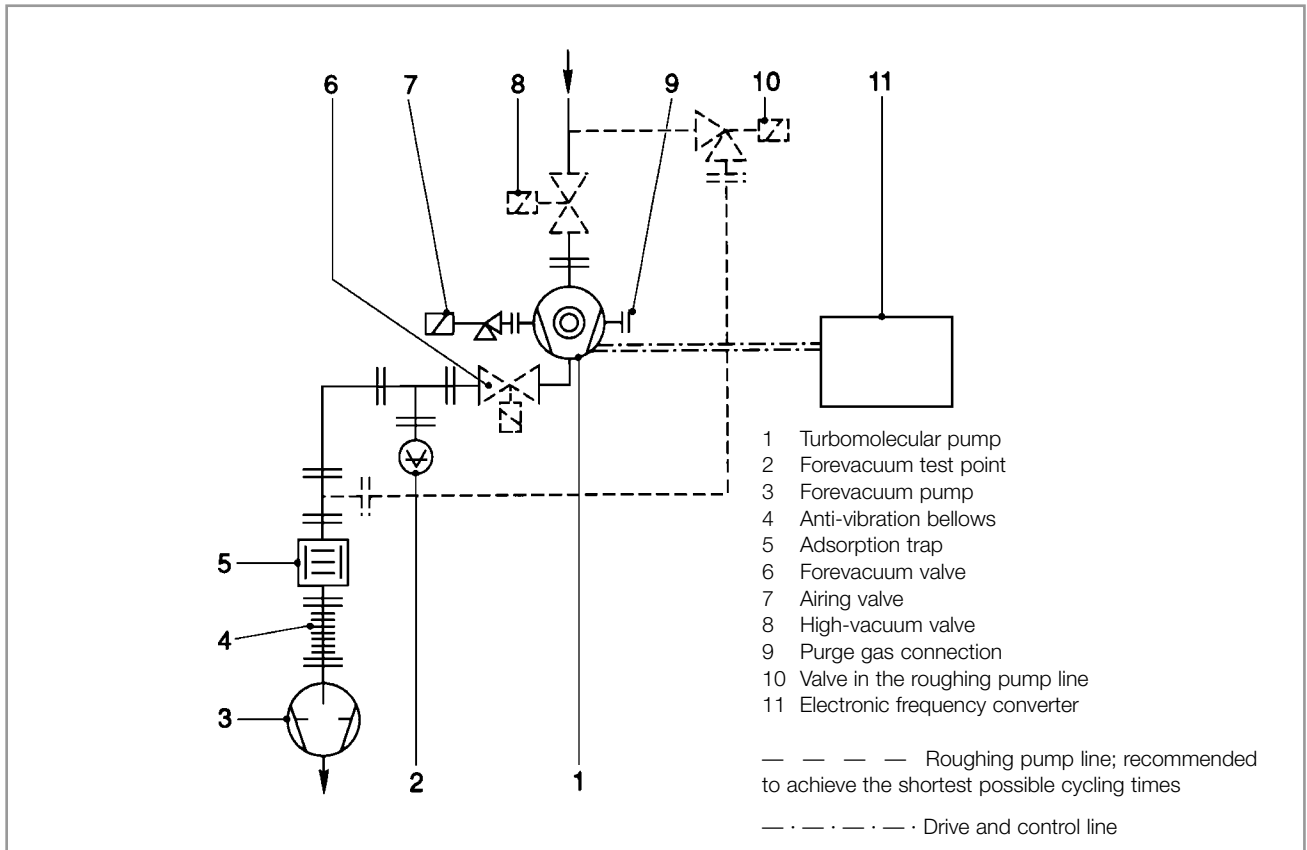

Fig. 6 Schematic of a turbomolecular pump system

Flange heating

(only for pumps with the CF flange)

The flange heater is used to bake out, under automatic control, the high-vacuum connection port at the TURBOVAC and the mating flange on the vacuum chamber.

The bakeout jacket or flange heater is mounted directly to the TURBOVAC intake flange. This can be done even with the pump flanged to the vacuum chamber.

Risk of injury!

The pump can become so hot during operation (> 70°C, 158 °F) as to represent a burn hazard. Shield the hot components against contact.

Warning



The pump running noise is below 70 dB(A); no noise-insulating measures are required.

3.4 Forevacuum connection

Forevacuum pump A suitable forevacuum pump is to be connected to the forevacuum connection flange.

Fig. 6 shows schematically the design of a pump system incorporating a TURBOVAC turbomolecular pump and a TRIVAC forevacuum pump with anti-suckback valve.

Anti-suckback valve When using a forevacuum pump not having an anti-suckback valve, a separate safety valve should be provided. The safety valve keeps oil from backstreaming from the forevacuum pump and into the TURBOVAC when the system is not running.

Sorption trap We recommend installing a sorption trap in the forevacuum line to insure that the forevacuum chamber in the TURBOVAC remains largely free of oil vapors during operation, as well.

Install a roughing pump line to achieve the shortest possible cycling times.

Be sure that there is sufficient vibration decoupling between the TURBOVAC and the forevacuum pump.

Warning



The forevacuum line must be tight.

Hazardous gases could escape from leaks or the gases being pumped could react with air or humidity.

3.5 Connecting the cooling

Air cooling

The air cooling unit is available as a supplementary kit for retrofitting.

When installing the air-cooled TURBOVAC, ensure that there is an unrestricted flow of air to the fan.

Always maintain a minimum distance of 20 cm (8 inch) to the nearest object.

Ensure that no heated air from neighboring equipment will be drawn in by the fan.

Connect the fan in the air ventilation unit to the AC mains.

Make the electrical connection for the ventilation unit in such a way that it will be started and stopped together with the pump itself.

Observe the information given in the operating instructions for the air ventilation unit (GA 05.199).

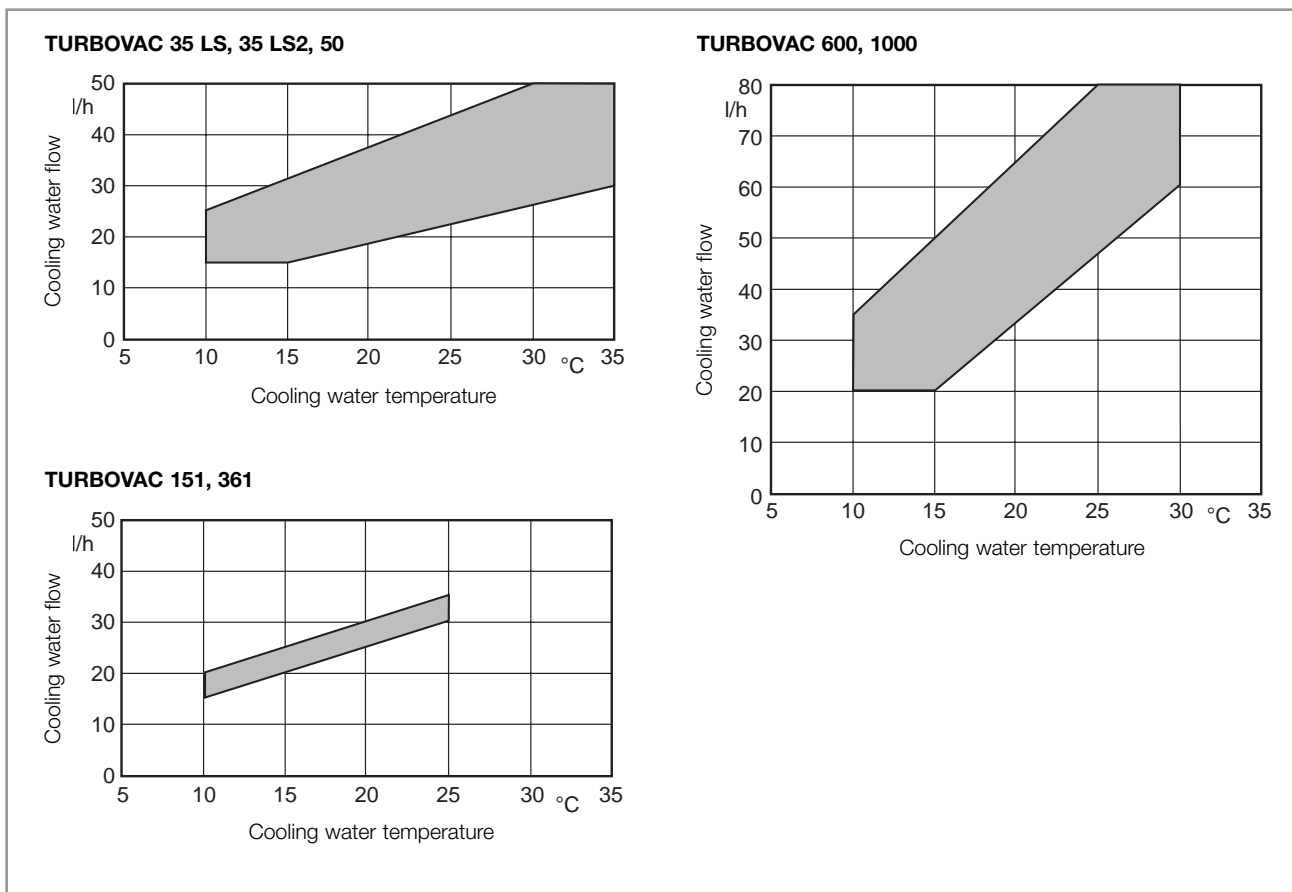

Fig. 7 Cooling water consumption

Water cooling

When attaching the water cooling unit to the TURBOVAC 35 LS, 35 LS2 and 50, remove the pump foot and then bolt the cooling unit to the bottom of the pump. The mounting bolts are provided with the water cooling unit.

Connect the coolant hoses to the hose nipples and secure with hose clamps.

If the coolant flow is turned on and off by means of a solenoid valve, make the electrical connection in such a way that coolant flow will be started and stopped together with the pump itself.

Cooling water specifications

Inlet pressure	3 to 7 bar absolute
Cooling water requirement, inlet temperature	See Fig. 7
Appearance	Colorless, clear, free of oils and greases
Sediments	< 250 mg/l
Particle size	< 150 µm
pH value	7 to 8.5
Overall hardness (total alkaline earths)	max. 20 ° German hardness scale (= 3.57 mmol/l)

3.6 Connecting the purge gas and airing device

See Section 4.1 for suited gases, see Section 4.6 for different venting methods.

TURBOVAC 35 LS, 35 LS2 and 50 with KF or ISO-K connectors

The TURBOVAC is aired through the system.

TURBOVAC 50 with CF connector and 151, 361

If the pump cannot be aired through the system, then a power failure airing valve shall be attached to the airing connection flange. This power failure airing valve prevents oil vapor from the forevacuum line from diffusing back into the system.

TURBOVAC 151 C, 361 C, 600 C and 1000 C

Either attach a power failure airing valve to the airing connection flange or a purge gas and airing valve at the purge gas connection flange.

Which of the two flanges is used will depend on the process.

When pumping **clean, non-corrosive gases**, a power failure airing valve is to be attached.

When pumping **reactive media**, connect a purge gas and airing valve.

Please contact Leybold for assistance in making the decision as to which media can be pumped with or without purge gas.

In processes which require purge gas the pump will have to be aired, when it is switched off, through the purge gas valve.

Observe the operating instructions for the purge gas and airing valve.

3.7 Connecting the TURBOTRONIK

Use the connector cable to attach the TURBOVAC and the TURBOTRONIK; see the operating instructions on the TURBOTRONIK for details.

Risk of injury!

Dangerous voltages are present at the mains connections. Before beginning with any maintenance or service work on the pump, disconnect the pump from all power supplies.

Operate the pump only with the matching frequency converter and connector line.

Voltages of up to 400 V will be present at the connection cable between the frequency converter and the pump; mains voltage will be present at the fan, the flange heater, the valves and their supply leads.

Route the conductors and cables so as to protect them from damage.

The connections are of the IP 40 safety classification. Do not expose the pump, frequency converter or connectors to dripping water.

The TURBOVAC **35 LS** must only be operated with a modified NT 12 frequency converter. Please consult with Leybold.

Warning



4 Operation

4.1 Media Compatibility/ Purge Gases

Caution Unless appropriate accessories and attachments are used, the TURBOVAC **is not** suitable for aggressive or corrosive media, or those containing dust. When handling corrosive media the C version pump must be operated with purge gas; when handling media containing dust, a fine-mesh filter must be installed.

Some media (such as aluminum trichloride) can sublime inside the pump and form deposits. Thick deposits reduce the play between moving parts to the point that the pump could seize. In some processes deposits can be prevented by heating the pump. Please consult with us in case such problems arise.

Corrosive gases (such as chlorine) can destroy the rotors.

Danger of ignition During operation the pressure inside the TURBOVAC is so low that there is no danger of ignition (at pressures below about 100 mbar, 75 Torr). A hazardous condition will be created if flammable mixtures enter the hot pump at pressures above 100 mbar (75 Torr). During operation the pump can reach temperatures as high as 120°C (248 °F). Sparks could occur in case of damage to the pump and these could ignite explosive mixtures.

We would be glad to consult with you as regards the media which can safely be handled with this unit.

Purge gas

Suited gases Suited are all gases,

- which will not cause corrosion or pitting in aluminium and steel and
- which in connection with process deposits in the pump will not cause corrosion or sticking.

For venting and as the purge gas we recommend inert gases like nitrogen or argon. The temperature of these gases should be between 5 °C and 80 °C, max. relative humidity should not exceed 10 ppm.

In individual cases and after consultation also dry, filtered, oil-free air or filtered ambient air may be used (filter mesh < 1µm).

Filters Change the filters after some time, at least annually.

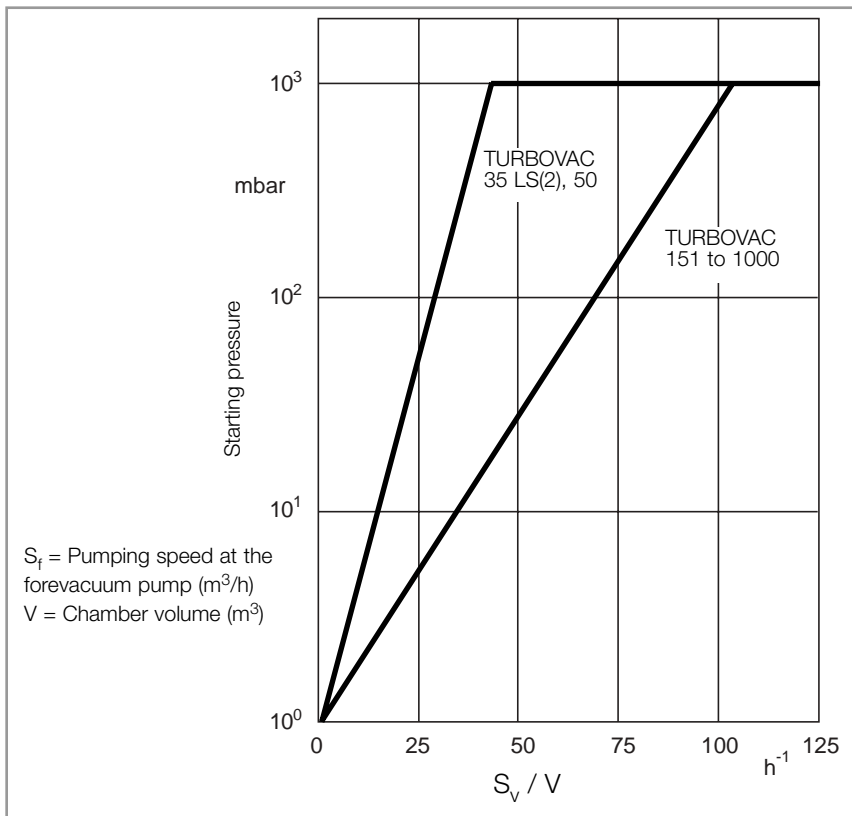

Fig. 8 Determining the starting pressure for a TURBOVAC when evacuating larger volumes

4.2 Start-up

The starting pressure for the TURBOVAC can be read from the chart reproduced in Fig. 8.

Where $S_f / V > 100[h^{-1}]$, the forevacuum pump and the TURBOVAC can be switched on simultaneously.

In such a situation the TURBOVAC serves from the very outset as an effective baffle.

When dealing with larger volumes, the vacuum chamber will first have to be pumped down with the forevacuum pump.

Then switch on the cooling and the TURBOVAC (at the TURBOTRONIK).

Kindly refer to the TURBOTRONIK operating instructions for details.

Avoid impact and vibration while the pump is running.

Starting pressure

Vibrations

4.3 Bakeout

If pressures in the range of 10^{-8} mbar are to be developed within a short period of time, the vacuum chamber and the components installed therein will have to be baked out. In addition, the TURBOVAC can be baked out using the flange heater provided for this purpose.

Protect the rotor against intensive, direct heat radiation. When baking out at the forevacuum side – at a sorption trap, for example – ensure that the components attached direct are not heated to more than 80 °C (176 °F).

The forevacuum pump must be in operation so as to eliminate the vapors liberated at the sorption trap.

4.4 Operation

Warning



Risk of injury!

The pump can become so hot during operation ($> 70^{\circ}\text{C}$, 158°F) as to represent a burn hazard. Note the symbols on the pump pointing to the hazards, and in the case of a hot pump wear the required protective clothing.

Caution

Exposure of the pump to accelerating forces must be avoided or reduced to such an extent that the rotor unit will not be excited by vibrations. In the case of critical applications you must consult our Applications Dept. first.

4.5 Switching Off

Switch off the TURBOVAC at the TURBOTRONIK.

Refer to the TURBOTRONIK operating instructions for details.

Venting

Switch off the forevacuum pump.

Vent the TURBOVAC before it has come to a full standstill; refer to Section 4.6.

In TRIVAC pumps the built-in anti-suckback valve will close automatically and shut off the forevacuum line. When using forevacuum pumps without an anti-suckback valve, close the valve in the forevacuum line.

Close off the cooling water supply or switch off the ventilation immediately after switching off the TURBOVAC in order to avoid condensate formation in the pump.

If the pump previously handled corrosive gases, it will be necessary to purge the pump with dry nitrogen for one hour prior to shut-down. When the system is not in operation, ensure that neither ambient air nor cleaning agents can enter the TURBOVAC.

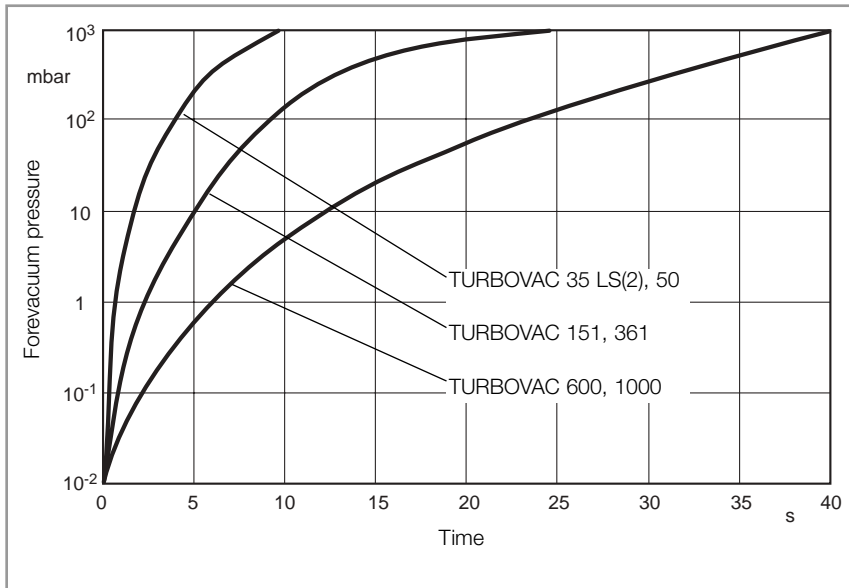

Fig. 9 Curves showing the pressure rise

4.6 Venting

As to suitable gases, see Section 4.1.

Venting Methods

There are three different methods of venting the turbomolecular pump.

In the case processes requiring a purge gas, the pump must be vented via the purge gas and venting valve when shutting the pump down.

When additionally venting the vacuum chamber, the venting function of the purge gas and venting valve must be opened before opening the chamber valve. This will ensure the presence of a higher pressure in the area of the ball bearings compared to the remaining vacuum area. This will prevent particles, dust or aggressive gases from being forced through the bearings into the not yet vented motor chamber of the pump.

Cautious venting of the pump is possible from the high vacuum side, since here the bearing forces will be lowest. When doing so, no free jet of gas must be allowed to form on the rotor so as to avoid exposing the rotor to additional forces.

When venting the pump through its foreline connection, neither oil nor particles may be entrained in the gas flow from the forevacuum side into the pump.

Purge gas and venting valve

High vacuum side

Foreline connection

Speed of the Pressure Rise

- Speed** All turbomolecular pumps may be vented at full speed. However, the pressure must not increase faster than specified through the pressure rise curve.
- Pressure rise curve**
- Particles** The pump must be vented significantly slower when there is the risk of particles entering into the pump from the process. During venting, the flow must be of the laminar type in both the vacuum chamber and the turbomolecular pump.
- The speed of the pressure rise during venting of the running pump will greatly influence the load on the rotor/stator pack and the bearings. The slower the pump is vented, the longer the service life of the bearings will be.
- The pump must not be vented to pressures above atmospheric pressure.

5 Maintenance

The pump must only be opened by such persons who have been authorised by Leybold to do so.

Caution

5.1 Maintenance Intervals

After 15,000 operating hours at the latest a standard bearing exchange will be recommended for the TURBOVAC 35 to 361 C. For the TURBOVAC 600 C and 1000 C a standard bearing exchange will be required after 10,000 operating hours at the latest.

Standard bearing exchange

Moreover we recommend to have the rotor assy. exchanged, depending on the thermal stress on the rotor, after 45,000 to 100,000 operating hours. This can only be done by Leybold Service. For this ask for a quotation.

When using purge gas valves

Depending on the degree of contamination of the purge gas used the filter will clog and will have to be exchanged (our experience indicates that this will become necessary after 1 to 6 months).

When using an adsorption trap

Regenerate or renew the adsorption agent regularly; refer to the operating instructions provided with the trap.

5.2 Leybold Service

Whenever you send in equipment to Leybold, indicate whether the equipment is contaminated or is free of substances which could pose a health hazard. If it is contaminated, specify exactly which substances are involved. You must use the form we have prepared for this purpose.

Contamination

A copy of the form has been reproduced at the end of these Operating Instructions: "Declaration of Contamination for Compressors, Vacuum Pumps and Components". Another suitable form is available from the Leybold homepage:

Form

www.leybold.com under the headline "Support & Downloads".

Attach the form to the equipment or enclose it with the equipment. Do not place it together with the equipment inside the PE bag.

This statement detailing the type of contamination is required to satisfy legal requirements and for the protection of our employees.

Leybold must return to the sender any equipment which is not accompanied by a contamination statement.

5.3 Cleaning

Contamination inside the TURBOVAC is indicated by a deterioration in performance, i.e. an increasing decline in working pressure.

If there is only slight contamination, such as a coating on the TURBOVAC interior surfaces due to exposure to the atmosphere over an extended period of time, for the CF version the flange heater can be used for cleaning.

The ultimate pressure must be monitored while baking out under vacuum.

When making the initial examination of the pump, mount blank flanges to eliminate any possibility of leaks and desorption in the vacuum chamber.

The pump will have to be disassembled if there is more extensive contamination. The LEYBOLD Customer Service Department will have to be consulted here in all cases.

Caution

The rotor is precision balanced; any change whatsoever, such as loosening or bending any rotor component, will make re-balancing necessary.

5.4 Removing the pump from the system

Switch off the pump and vent it as per the instructions in Sections 4.5 and 4.6.

Warning



Take the appropriate precautionary measures prior to opening the intake or discharge connection if the pump has previously handled hazardous gases.

If necessary, use gloves, a respirator and/or protective clothing and work under an exhaust hood.

Hazardous gases

Deposits

Desiccant

Close the pump

If the pump previously handled corrosive gases, then allow the purge gas to flow for as long as possible before detaching the pump from the system.

Remove the TURBOVAC from the system.

TURBOVAC pumps which are used in semiconductor processes, for example, will be contaminated with process gases. These gases may be toxic and hazardous to health. In addition, deposits with similarly dangerous properties may have formed. Many of these gases and deposits form acids when they come into contact with humid air. This will result in serious corrosion damage to the pump.

To avoid health hazards and corrosion damage when the pumps are detached from the system, lay a container of desiccant on the splinter guard and then close the pump immediately at all flange connections. Store the pump, with a desiccant, in a PE bag.

A packing set is included with TURBOVAC models with a "C" in the type designation. Use this packing set after detaching the pump from the system.

Faulty (leaky) packing of a TURBOVAC will nullify the guarantee.

Ordering data

Packing set for high-vacuum connection flange	Order No.
DN 100/160	200 91 240
DN 200	200 91 295
DN 250, 6" ANSI	200 91 262

Pack the pump so that it cannot be damaged during shipping and so that no contaminants can escape from the packaging. Protect in particular the flanges, the coolant connection nipples and the cable grommets.

If you return a pump to Leybold, be absolutely sure to observe the instructions given in Section 5.2.

6 Troubleshooting

When the connector cable to the TURBOVAC is attached, the outputs of the TURBOTRONIK frequency converter are not free of voltage.

Warning



Before commencing troubleshooting procedures, make the following simple checks:

- Is the TURBOVAC being supplied with electrical energy?
- Are the connections . . .
 - from the mains power cord to the frequency converter
 - at the connector cable from the frequency converter to the mains network in good working order?
- If a water flow monitoring device is connected, is it functioning properly? Check the water flow monitoring device by jumping its terminals and starting the TURBOVAC.
- Is the forevacuum pressure sufficient?
- Is the vacuum chamber free of leaks?

Observe also the troubleshooting instructions for the TURBOTRONIK.

Troubleshooting

Malfunction	Possible cause	Corrective action
TURBOVAC does not start.	Motor connection cable not attached, is loose or is defective. Pump has seized.	Check the motor connection cable and connect correctly; replace if necessary. Replace the pump.
TURBOVAC generates loud running noises and vibrations.	Rotor is out of balance. Bearing is defective. Pump running within the natural frequency range of the system, causing resonance.	Balance the rotor (only by the Leybold Service Department). Bearings will have to be replaced (only by the Leybold Service Department). Change the masses of the system or install vibration damper to isolate oscillations.
The TURBOVAC does not achieve ultimate pressure.	Measurement device is defective. Measurement gauges are soiled. Leak at the system, lines or pump. Minor grime collection at the pump. The pump is oily. Forevacuum pump with insufficient pumping speed or ultimate pressure which is too high. Leak at the power cord passage port. TURBOVAC is rotating in the wrong direction.	Check the measurement device. Clean or replace the measurement gauges. Locate the leaks. Bake out the pump; see Section 5.3. Have the pump cleaned (only by the Leybold Service Department). Check ultimate pressure of the forevacuum pump or install a more powerful forevacuum pump. Locate and repair leaks (only by the Leybold Service Department). Check the connector lines; interchange poles if necessary.
TURBOVAC overheats (malfunction indication at the TURBOTRONIK).	Forevacuum pressure too high. Gas volume too great / leak in the system. Ventilation unit blocked. Ambient temperature is too high. Cooling water is lacking or insufficient. Bearings are defective.	Check the forevacuum pump; install a more powerful forevacuum pump if necessary. Seal leak; install a more powerful forevacuum pump if necessary. Ensure sufficient supply of cooling air. Route cooler air to the fan or employ water cooling option. Ensure sufficient supply of cooling water. Have the pump repaired (only by the Leybold Service Department).
The TURBOVAC or the vacuum chamber is contaminated with oil.	Anti-suckback valve at the forevacuum pump is defective. The TURBOVAC was not aired or improperly aired when shut down. System configured incorrectly; oil vapor streams back during forepump operation. Sorption trap is saturated.	Repair or replace the forevacuum pump. Check the airing valve and replace if indicated. Air the TURBOVAC correctly; see Section 4.6. Install a roughing line or pre-pump for a shorter period of time or install a sorption trap. Regenerate or replace the sorption trap.

7 Waste Disposal

The equipment may have been contaminated by the process or by environmental influences. In this case the equipment must be decontaminated in accordance with the relevant regulations. Leybold offers this service at fixed prices. Further details are available on request.

Contaminated parts can be detrimental to health and environment. Before beginning with any work, first find out whether any parts are contaminated. Adhere to the relevant regulations and take the necessary precautions when handling contaminated parts.

Separate clean components according to their materials, and dispose of these accordingly. Leybold offers this service free of charge. Further details are available on request.

When sending any equipment to Leybold, observe the regulations given in Section "5.2 Leybold Service".

Contamination

Warning



EC Manufacturer's Declaration

in the spirit of Appendix IIb to the 98/37/EG Machinery Guidelines

We - Leybold Vacuum GmbH - herewith declare that operation of the incomplete machine defined below, is not permissible until it has been determined that the machine into which this incomplete machine is to be installed, meets the regulations of the EC Directive on Machinery.

When using the appropriate Leybold accessories, e.g. connectors, lines, flange heaters and fans and when powering the pump with the specified Leybold frequency converters, the protection level prescribed in the EMC Guidelines will be attained.

Designation of the products Turbomolecular pump

Models:

Part Nos.:

TURBOVAC 35 LS, 35 LS2, 50 D2	856 64, 856 66, 856 68
TURBOVAC 50	853 99, 854 00, 854 01, 854 02, 800150V0010
TURBOVAC 151, 151 C	856 31, 856 32, 856 35, 856 33
TURBOVAC 361, 361 C	856 70, 856 71, 856 72, 856 73, 856 74, 856 75, 856 77,
TURBOVAC 600 C	800150V0005, 800150V0015, 800150V0017
TURBOVAC 1000 C	855 35, 855 36, 855 37, 855 38, 855 39, 894 89, 117 64

Related, harmonized standards

- EN 1012 - 2: 1996 Compressors and vacuum pumps. Safety requirements.
Part 2: Vacuum pumps

Cologne, April 15, 2005



Marcus Eisenhuth
Vice-President
Head of Product Development

Cologne, April 15, 2005



Ralf Adamietz
Head of Construction

 **Leybold**
vacuum

Leybold Vacuum GmbH
Bonner Strasse 498
D-50968 Cologne
Phone: ++49 (0)221 347-0
Fax: ++49 (0)221 347-1250
documentation@leybold.com

www.leybold.com

Declaration of Contamination of Compressors, Vacuum Pumps and Components

The repair and / or servicing of compressors, vacuum pumps and components will be carried out only if a correctly completed declaration has been submitted. **Non-completion will result in delay.** The manufacturer can refuse to accept any equipment without a declaration.

A separate declaration has to be completed for every single component.

This declaration may be completed and signed only by authorised and qualified staff.

Customer/Dep./Institute: _____ _____ Address _____ _____ Person to contact: _____ Phone: _____ Fax: _____ Order number of customer: _____	Reason for returning <input checked="" type="checkbox"/> applicable please mark <input type="checkbox"/> repair <input type="checkbox"/> chargeable <input type="checkbox"/> warranty <input type="checkbox"/> replacement <input type="checkbox"/> chargeable <input type="checkbox"/> warranty <input type="checkbox"/> DKD-calibration <input type="checkbox"/> Factory calibration restoring goods because of following reason: <input type="checkbox"/> rent/loan <input type="checkbox"/> for credit <input type="checkbox"/> against exchange <input type="checkbox"/> exchange already received/arranged
---	--

A. Description of the equipment (machine or component)	Ancillary equipment
Type: _____	_____
Part number: _____	_____
Serial number: _____	_____
Type of oil used: _____	_____

B. Condition of the equipment							
	No	Yes	No	Contamination:	No	Yes	
1. Has the equipment been used	<input type="checkbox"/>	<input type="checkbox"/>	<input checked="" type="checkbox"/>	toxic	<input type="checkbox"/>	<input type="checkbox"/>	
2. Drained (Product/service fluid)	<input type="checkbox"/>	<input type="checkbox"/>	<input type="checkbox"/>	corrosive	<input type="checkbox"/>	<input type="checkbox"/>	
3. All openings sealed airtight	<input type="checkbox"/>	<input type="checkbox"/>	<input type="checkbox"/>	mmicrobiological	<input type="checkbox"/>	<input type="checkbox"/>	
4. Purged	<input type="checkbox"/>	<input type="checkbox"/>	<input type="checkbox"/>	explosive	<input type="checkbox"/>	<input type="checkbox"/>	
If yes which cleaning agent: _____				radioactive	<input type="checkbox"/>	<input type="checkbox"/>	
and which method of cleaning: _____				other harmful substances	<input type="checkbox"/>	<input type="checkbox"/>	

C. Description of processed substances (Please fill in absolutely)
1. What substances have come into contact with the equipment: Trade name and / or chemical term of service fluids and substances processed, properties of the substances; According to safety data sheet (e.g. toxic, inflammable, corrosive, radioactive)
Tradename: _____ Chemical name: _____ Residues: _____
a) _____ <input type="checkbox"/> Yes <input type="checkbox"/> No
b) _____ <input type="checkbox"/> Yes <input type="checkbox"/> No
c) _____ <input type="checkbox"/> Yes <input type="checkbox"/> No
d) _____ <input type="checkbox"/> Yes <input type="checkbox"/> No
2. Are these substances harmful? Yes No
<input type="checkbox"/> <input type="checkbox"/>
3. Dangerous decomposition products when thermally loaded Yes No
<input type="checkbox"/> <input type="checkbox"/>
Which: _____

Components contaminated by microbiological, explosive or radioactive products will not be accepted without written evidence of decontamination.

D. Legally binding declaration

I / we hereby declare that the information supplied on this form is accurate and sufficient to judge any contamination level.

Name of authorised person (block letters): _____	
date _____ signatur of authorised person _____	firm stamp

Sales and Service Net Worldwide

Germany

Leybold Vacuum GmbH
Bonner Strasse 498
D-50968 Cologne
Phone: +49-221-347 1234
Fax: +49-221-347 1245
sales@leybold.com

Leybold Vacuum GmbH
Sales Area North/East
Branch office Berlin
Buschkrugallee 33
1. Obergeschoss
D-12359 Berlin
Phone: +49-30-435 609 0
Fax: +49-30-435 609 10
sales.berlin@leybold.com

Leybold Vacuum GmbH
Sales Area South/Southwest
Branch office Munich
Karl-Hammerschmidt-Strasse 38
D-85609 Aschheim/Dornach
Phone: +49-89-357 33 90
Fax: +49-89-357 33 933
sales.muenchen@leybold.com
service.muenchen@leybold.com

Leybold Vacuum GmbH
Sales Area West
Branch office Cologne
Emil-Hoffmann-Straße 43
D-50996 Cologne-Suerth
Phone: +49-221-347 1270
Fax: +49-221-347 1291
sales.koeln@leybold.com

Leybold Vacuum GmbH
Service Center
Emil-Hoffmann-Straße 43
D-50996 Cologne-Suerth
Phone: +49-221-347 1439
Fax: +49-221-347 1945
service@leybold.com

Leybold Vacuum GmbH
Mobile after sales service
Emil-Hoffmann-Straße 43
D-50996 Cologne-Suerth
Phone: +49-221-347 1765
Fax: +49-221-347 1944
kundendienst@leybold.com

Leybold Vacuum
Dresden GmbH
Zur Wetterwarte 50, Haus 304
D-01109 Dresden
Service:
Phone: +49-351-88 55 00
Fax: +49-351-88 55 041
info@leybold-dresden.de
www.leybold-dresden.de

Europe

Belgium
Leybold Vacuum Nederland B.V.
Belgisch bijkantoor
Leuvensesteenweg 542-9A
B-1930 Zaventem
Sales:
Phone: +32-2-711 00 83
Fax: +32-2-720 83 38
sales.belgium@leybold.com
Service:
Phone: +32-2-711 00 82
Fax: +32-2-720 83 38
service.belgium@leybold.com

France
Leybold Vacuum France S.A.
7, Avenue du Québec
Z.A. de Courtaboef, B.P. 42
F-91942 Courtaboef Cedex
Sales and Service:
Phone: +33-1-69 82 48 00
Fax: +33-1-69 07 57 38
sales.france@leybold.com

Leybold Vacuum France S.A.
Valence Factory
640, Rue A. Bergès - B.P. 107
F-26501 Bourg-lès-Valence Cedex
Phone: +33-4-75 82 33 00
Fax: +33-4-75 82 92 69
marketing.valence@leybold.fr

Great Britain
Leybold Vacuum UK Ltd.
Waterside Way, Plough Lane
GB-London SW17 0HB
Sales:
Phone: +44-20-8971 7000
Fax: +44-20-8971 7001
sales@leybold.com
Service:
Phone: +44-20-8971 7030
Fax: +44-20-8971 7003
service@leybold.com

Italy
Leybold Vacuum Italia S.p.A.
8, Via Trasimeno
I-20128 Milano
Sales:
Phone: +39-02-27 22 31
Fax: +39-02-27 20 96 41
sales@leybold.it
Service:
Phone: +39-02-27 22 31
Fax: +39-02-27 20 96 41
service@leybold.it
Field Service Base
Z.I. Le Capanne
I-05021 Acquasparta (TR)
Phone: +39-0744-93 03 93
Fax: +39-0744-94 42 87
service@leybold.it

Netherlands
Leybold Vacuum Nederland B.V.
Computerweg 7
NL-3542 DP Utrecht
Sales and Service:
Phone: +31-346-58 39 99
Fax: +31-346-58 39 90
sales.netherlands@leybold.com
service.netherlands@leybold.com

Spain
Leybold Vacuum España S.A.
C/ Huelva, 7
E-08940 Cornellà de Llobregat
(Barcelona)
Sales:
Phone: +34-93-666 46 16
Fax: +34-93-666 43 70
sales.spain@leybold.com
Service:
Phone: +34-93-666 49 51
Fax: +34-93-685 40 10

Sweden
Leybold Vacuum Scandinavia AB
Box 9084
SE-40092 Göteborg
Sales and Service:
Phone: +46-31-68 84 70
Fax: +46-31-68 39 39
info@leybold.se
Visiting/delivery address:
Datavägen 57B
SE-43632 Askim

Switzerland
Leybold Vacuum Schweiz AG
Leutschenbachstrasse 55
CH-8050 Zürich
Sales:
Phone: +41-1-308 40 50
Fax: +41-1-302 43 73
sales@leybold.ch
Service:
Phone: +41-1-308 40 62
Fax: +41-1-308 40 60

America

USA
Leybold Vacuum USA Inc.
5700 Mellon Road
Export, PA 15632
info@leyboldvacuum.com
Sales:
Eastern & Central time zones
Phone: +1-724-327-5700
Fax: +1-724-733-1217
Pacific, Mountain,
Alaskan & Hawaiian time zones
Phone: +1-480-752-9191
Fax: +1-480-752-9494
Service:
Phone: +1-724-327-5700
Fax: +1-724-733-3799

Asia

P.R. China
Leybold Vacuum (Tianjin)
International Trade Co., Ltd.
Beichen Economic
Development Area (BEDA),
No. 8 Western Shuangchen Road
Tianjin 300400, China
Sales and Service:
Phone: +86-22-2697 0808
Fax: +86-22-2697 4061
leybold@leybold.com.cn

Leybold Vacuum (Tianjin)
Equipment Manufacturing Co., Ltd.
Beichen Economic
Development Area (BEDA),
No. 8 Western Shuangchen Road
Tianjin 300400, China
Phone: +86-22-2697 0808
Fax: +86-22-2697 4061
Fax: +86-22-2697 2017
leybold@leybold.com.cn

Leybold Vacuum (Tianjin)
International Trade Co., Ltd.
Beijing Branch:
1-908, Beijing Landmark Towers
8 North Dongsanhuan Road
Chaoyang District
Beijing 100004, China
Sales and Service:
Phone: +86-10-6590-7607
Fax: +86-10-6590-7622

Leybold Vacuum (Tianjin)
International Trade Co., Ltd.
Shanghai Branch:
Add: No. 33, 76 Futedong San
Rd., Waigaoqiao FTZ,
Shanghai 200131, China
Sales and Service:
Phone: +86-21-5064-4666
Fax: +86-21-5064-4668
leybold_sh@leybold.com.cn

Leybold Vacuum (Tianjin)
Guangzhou Branch:
Add: G/F, #301 Building,
110 Dongguangzhuang Rd.
Tianhe District,
Guangzhou 510610, China
Sales:
Phone: +86-20-8723-7873
Phone: +86-20-8723-7597
Fax: +86-20-8723-7875
leybold_gz@leybold.com.cn

India
Leybold Vacuum India Pvt Ltd.
A-215 Road No. 30
MIDC Wagle Industrial Estate
Thane(W) - 400 604 Maharashtra
India
Sales and Service:
Phone: +91-22-2581 2929
Fax: +91-22-2581 2626
ivt2004@yahoo.com

Japan
Leybold Vacuum
Japan Co., Ltd.
Head Office
Tobu A.K. Bldg. 4th Floor
23-3, Shin-Yokohama
3-chome
Kohoku-ku, Yokohama-shi
Kanagawa-ken 222-0033
Sales:
Phone: +81-45-4713330
Fax: +81-45-4713323

Leybold Vacuum
Japan Co., Ltd.
Osaka Branch Office
MURATA Bldg. 7F
2-7-53, Nihi-Miyahara
Yodogawa-ku
Osaka-shi 532-0004
Sales:
Phone: +81-6-6393-5211
Fax: +81-6-6393-5215

Leybold Vacuum
Japan Co., Ltd.
Tsukuba Technical S.C.
Tsukuba Minami Daiichi
Kogyo Danchi
21, Kasumi-no-Sato,
Ami-machi, Inashiki-gun
Ibaraki-ken, 300-0315
Service:
Phone: +81-298-89-2841
Fax: +81-298-89-2838

Korea
Leybold Vacuum Korea Ltd.
#761-4, Yulkeum-ri,
SungHwan-eup, Cheonan-City
Choongchung-Namdo,
330-807, Korea
Sales:
Phone: +82-41-580-4420
Fax: +82-41-588-3737
Service:
Phone: +82-41-580-4415
Fax: +82-41-588-3737

Singapore
Leybold Vacuum
Singapore Pte Ltd.
No.1, International
Business Park,
B1-20B, The Synergy
Singapore 609917
Sales and Service:
Phone: +65-66652910
Fax: +65-65668202
vacuum@leyboldvac.com.sg

Taiwan
Leybold Vacuum Taiwan Ltd.
No 416-1, Sec. 3
Chung-Hsin Rd., Chu-Tung
Hsin-Chu, Taiwan, R.O.C.
Sales and Service:
Phone: +886-3-5833988
Fax: +886-3-5833999

Hotline

Sales: +49-221-347 1234
Service: +49-221-347 1765

sales@leybold.com
service@leybold.com

Leybold Vacuum Products Inc.

5700 Mellon Road
Export, PA. 15632-8900
Phone: 724-327-5700
Fax: 724-325-3577
info@leyboldvacuum.com

Leybold Vacuum GmbH

Bonner Strasse 498
D-50968 Cologne
Phone: +49-221 347-0
Fax: +49-221 347-1250
info@leybold.com

Leybold
vacuum

www.leybold.com